



- odisha urban housin mission

23 Projects for approval under BLC vertical

Presented to 34th CSMC on 30th May. 2018, MoHUA, New Delhi

by

Dr. Suresh Chandra Dalai, IAS
Mission Director

Housing and Urban Development Department
Government of Odisha

 @AWAAS.OUHM

 @OUHMAWAAS

 ouhmodisha@gmail.com



Progress of PMAY (U)



Progress of PMAY (U)



Indicators	Current Status
▪ Cities Approved	112
▪ Demand Survey Completed	Yes
▪ Total Demand	6.87 Lakhs
▪ Demand received through Common Service Centre and Online Application	4508
▪ Cases accepted/rejected (out of CSC demand)	Accepted-1432, Pending- 3050, Rejected-26
▪ Whether HFAPoA Submitted	In progress
▪ Whether AIP Submitted	Will be submitted along with HFAPoA
▪ Whether HFAPoA & AIP entered in MIS	-
▪ SLTC/CLTC staffs approved vs. placed	SLTC- 8/ CLTC- 72 (Agreement Signed)
▪ Target of DUs in 2018 - 19	1,00,000
▪ State Budgetary Provision for PMAY (U) in 2018 - 19	400 Cr.



Status of Mandatory Reforms



Mandatory Reforms	Current Status
<ul style="list-style-type: none"> Dispensing the need for separate Non Agricultural (NA) Permission 	Odisha Development Authorities Amendment Act has the provision for Removal of dual control of land use; (Achieved in 2015)
<ul style="list-style-type: none"> Prepare/amend their Master Plans earmarking land for Affordable Housing 	20% land reservations in Master Plans for Affordable Housing; (Achieved in 2015)
<ul style="list-style-type: none"> Single-window, time bound clearance for layout approval and building permissions 	Land and Building Plan approval is covered under RTPSA which mandates service delivery within 60 days. (Achieved in 2015) Common Application form (CAF) for Fast Track Single Window Approvals; (Achieved in 2016)
<ul style="list-style-type: none"> Adopt the approach of deemed building permission and layout approval on the basis of pre-approved lay outs and building plans. 	Presently under Building Plan regulation 2008 within 100 Sq.mtr exempted.
<ul style="list-style-type: none"> Amend or legislate existing rent laws on the lines of the Model Tenancy Act. 	Awaiting GoI suggestion.
<ul style="list-style-type: none"> Additional Floor Area Ratio (FAR)/Floor Space Index (FSI)/Transferable Development Rights (TDR) and relaxed density norms. 	<u>Notification No.HUD-HU-SCH-0002-2015-20719/dated14.08.2015;</u> As per policy for Housing for All in Urban Odisha 2015, additional FAR and TDR are provided for slum redevelopment and low cost housing. (Notified in 2015)



Key interventions In Legislative/ Regulatory Reforms



- Establishment of AWAAS- Odisha Urban Housing Mission
- Establishment of District Urban Housing Societies in 30 +1 districts.
- CDP Land Implementation Policy (CLIP), 2015
- Policy on Housing for All in urban areas of Odisha, 2015
- ODA Amendment Act, 2015
- Odisha Apartment Ownership Act
- TDR Rules notified
- Policy on Rehabilitation of slum / project evicted people – notified
- The Odisha Land Rights to Slum Dwellers Act, 2017



Progress of ongoing projects under PMAY (U)



Verticals	Houses Approved	Tendered	Work order Issued	Grounded/In Progress				Completed
				Foundation	Lintel	Roof	Total	
▪ ISSR	7,300	Yes	2,500	Condition precedent period is going on				
▪ AHP	6,462	Yes	5,262	-do-				
▪ BLC (New)	54,272		38,081	6,167	8,286	7,386	21,839	2,323
▪ BLC (Enhancement)								
▪ Total	68,034		45,843	6,167	8,286	7,386	21,839	2,323
▪ CLSS	No. of loan sanctioned							

Interface with MIS

Indicators	Current Status (No.)
▪ Survey entry made	57,516
▪ Projects approved:	211 (BLC-204, ISSR-3, AHP-4)
▪ Projects entered (7A/B/C/D)	210
▪ DUs approved under BLC	54,272
▪ Beneficiaries attached	42,972
▪ Houses geo-tagged	30,580
▪ Total fund transferred through DBT (Rs. Lakhs)	26496.50
▪ National Electronic Funds Transfer (NEFT)	76.30
▪ PFMS/ DBT	26420.20
▪ Aadhar Payment Bridge (APB)	

Completed Dwelling Units under BLC-PMAY(U)



ULB: Khariar NAC, Dist: Nuapada



ULB: BeMC, Berhampur, Dist: Ganjam



ULB: Phulbani Municipality, Dist: Kandhamal



ULB: Talcher Municipality, Dist: Angul



ULB: Sundargarh Municipality, Dist: Sundargarh

ACA to be released

Rs. In Lakhs

SI No	CSMC No	No of Projects / DUs	Project Cost	ACA Committed	ACA Released (1st Instalment)	ACA due against 1st Instalment
1	10th	41 / 23843	73765.1	35764.50	14305.80	0.00
2	20th	22 / 2115	6373.00	3172.50	1269.00	0.00
3	22nd	26 / 2836	8439.45	4254.00	1289.22	412.38
4	27th	88 / 20345	61124.25	30517.50	10317.00	1890.00
5	30th	27 / 5133	15640.29	7699.50	1563.00	1516.80
TOTAL		204 / 54272	165342.1	81408.00	28744.02	3819.18



Project proposals for approval under BLC of PMAY (U)

Adherence to the Conditions: Against the projects placed for approval.

Sl. No	Condition	Adherence
1	All proposed projects are on litigation free land?	Yes under BLC each beneficiary have their own RoR.
2	Status of Demand Survey, and timeline for completion, if not completed yet	Completed in the last stage of finalisation
3	If Demand Survey is complete, has the state shared the list of CLSS beneficiaries to the Ministry?	No
4	In case of In-Situ and BLC projects, whether beneficiaries have been identified and listed in the DPR along with their AHL-TIN from SECC data?	Yes, beneficiary selection has been done under each proposed project. However, the AHL-TIN SECC are being linked.
5	Timelines for Project Completion (Months) For all BLC Projects timelines must be within 2 years of release of funds from Government of India.	Yes, 12 months for BLC projects
6	Status of Physical Infrastructure like drainage, road, street lighting, solid waste management, etc? If not available, whether the provision has been made in the project on this account?	<p>The project is linked with existing infrastructure and in some ULBs the infrastructure is taken care by the UIB/ State Share.</p> <p>Every ULBs have mandatorily reserved 25% of the total budget for Basic services to urban Poor. This fund will be utilised in providing basic infrastructures. Further provisions are also done under 14th FC towards infrastructure.</p>
7	Whether the DPR mentions convergence with other centrally assisted programmes for provision of Infrastructure?	Yes, in some ULBs with Swachh Bharat Mission and AMRUT.

Adherence to the Conditions: Cont...

Sl. No	Condition	Adherence
8	Whether connection to Electricity & Water Supply has been planned under the project? The project shall not be considered complete unless the Houses are provided with Electricity & Water Supply	Yes all the dwelling units will be provided with individual toilets, water connection and electricity.
9	Status of Social Infrastructure?	Existing in the proposed areas.
10	Beneficiary details compiled as per Annexure 4A/ 4B?	Yes.
11	Project Proposals submitted as per Annexure 7A/7B/7C?	Yes.
12	Whether the DPR contains the Financial details/Funding pattern of the Project?	Yes.
13	Details of the proposed ownership of houses – in favor of Women/Joint ownership	Ownership will be in the name of the existing RoR.
14	Any other innovative approach taken by the state in proposed projects?	Beneficiaries who will go rain water harvesting will be incentivized by the State. Incentive will also be given for early completion of project.
15	Whether the Project Proposals are consistent and adhere to Guidelines in all aspects?	Yes.

Proposed Designs under BLC Vert - I

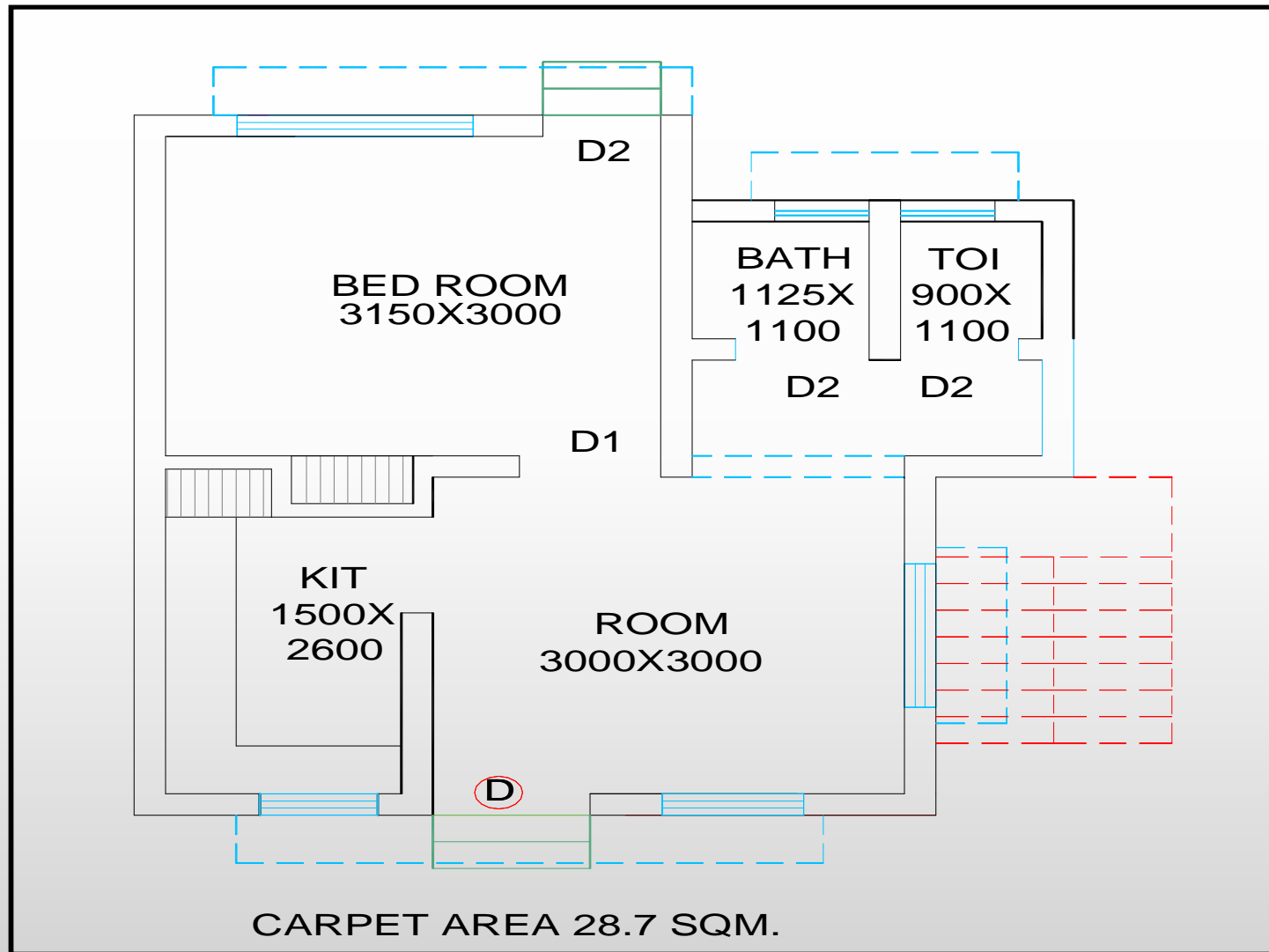

Proposed Designs under BLC Vert - II

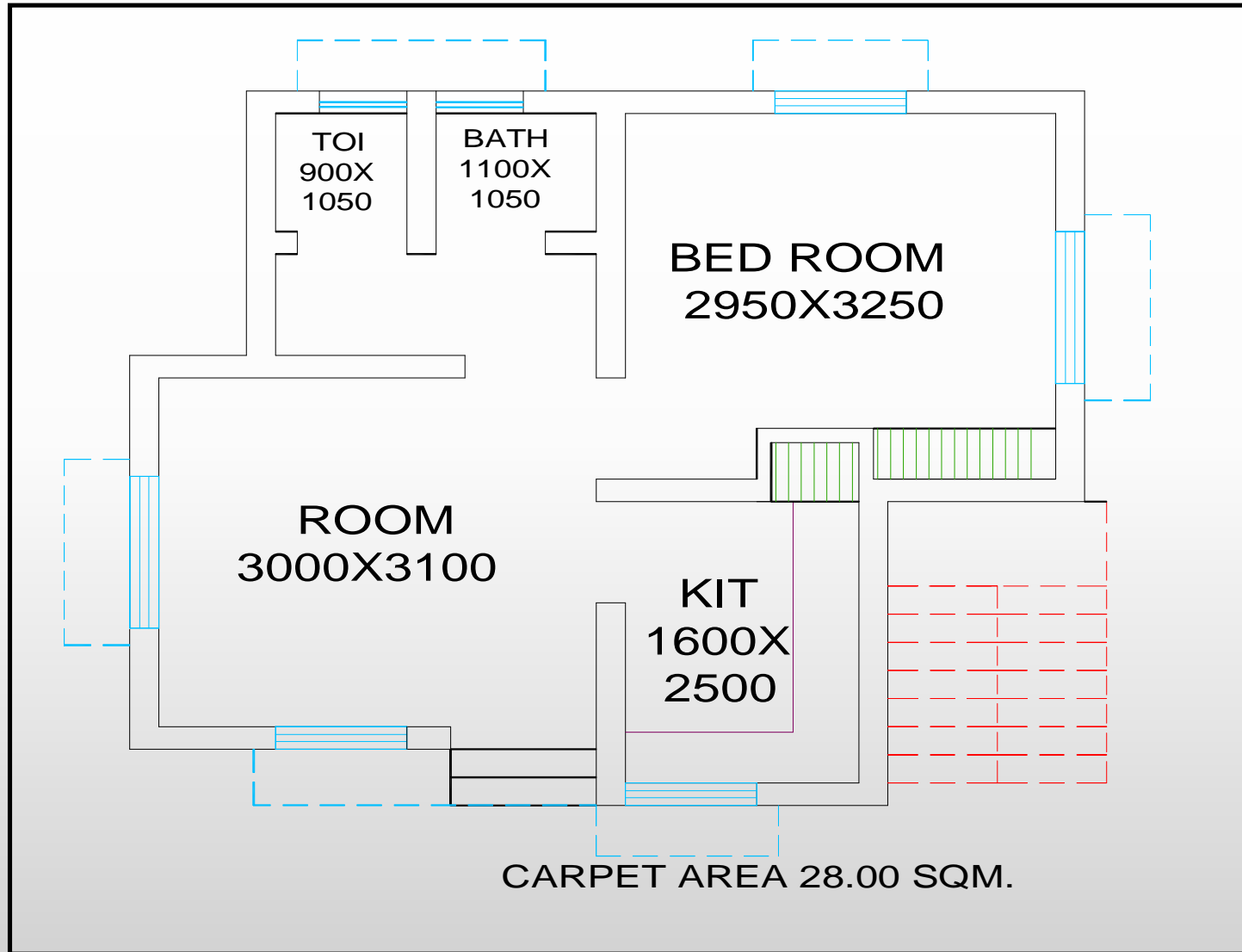

Proposed Designs under BLC Vert - III

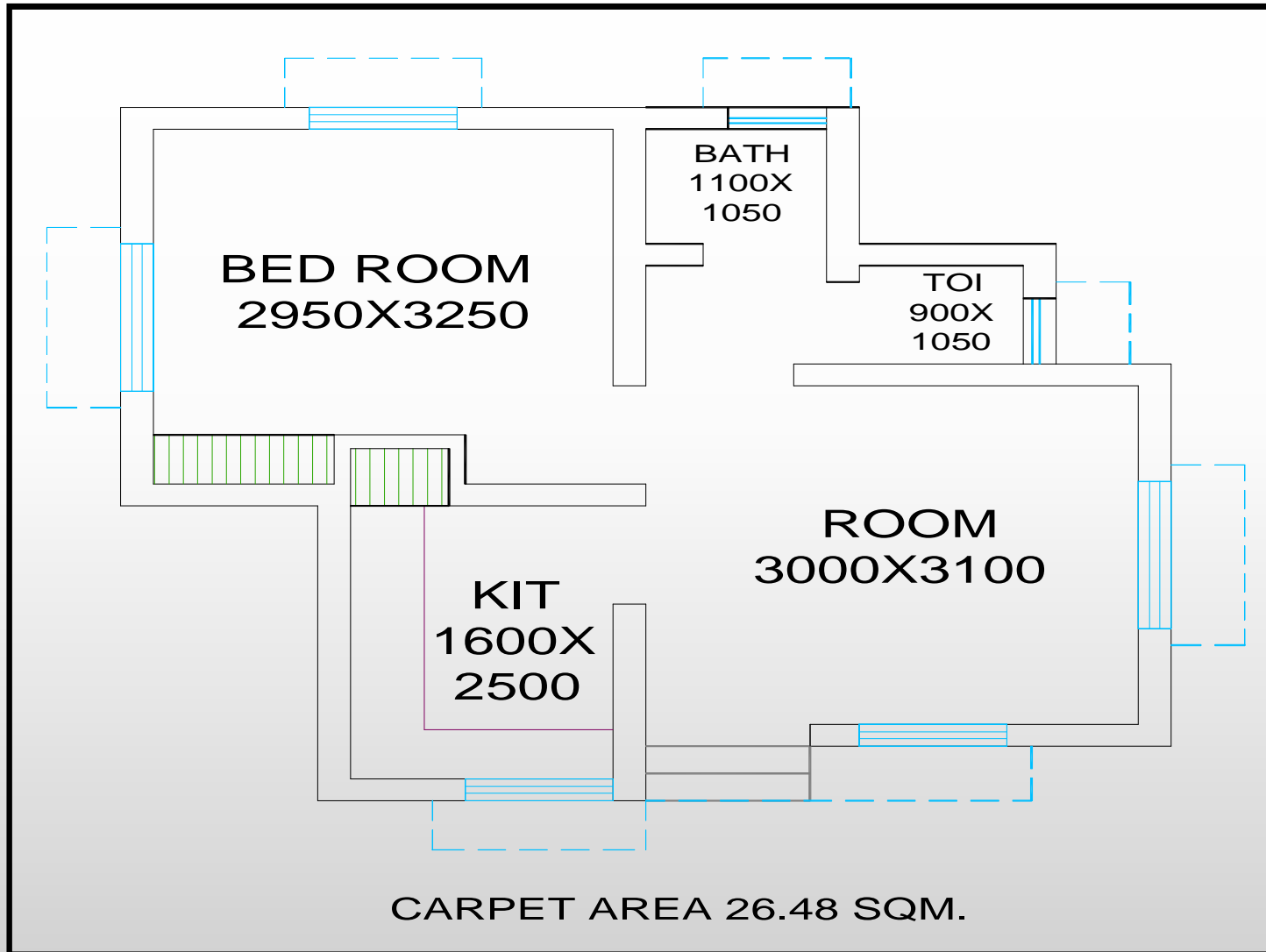

Structural Design

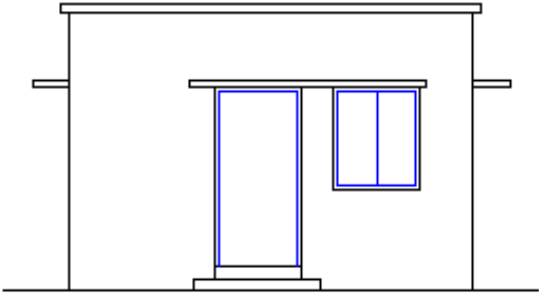

ELEVATION

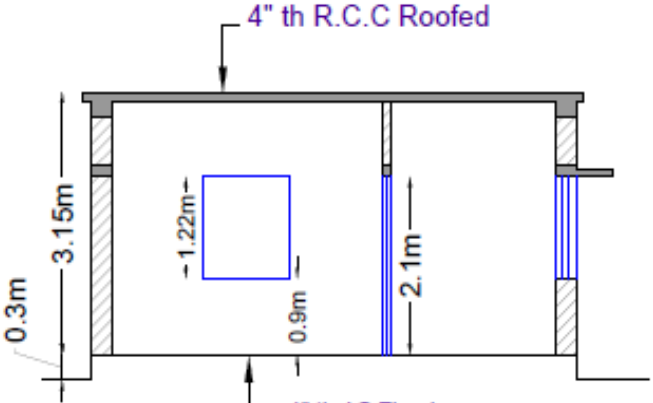

SECTION ON XX

- D- 1.05mx2.1m
- D1-0.75mx2.1m
- W- 1.05mx1.22m
- V- 0.625mx0.625m

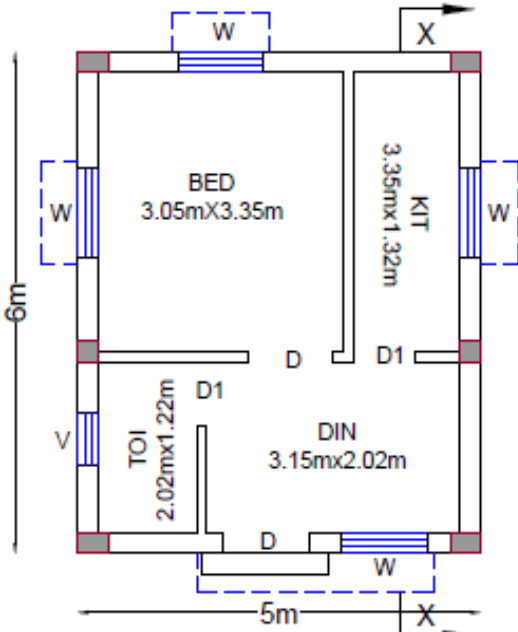

PLAN

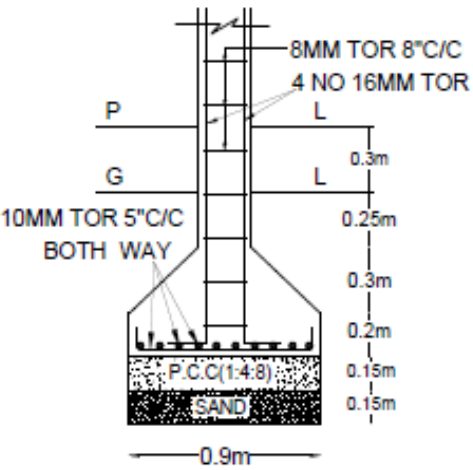

COLUMN FOUNDATION

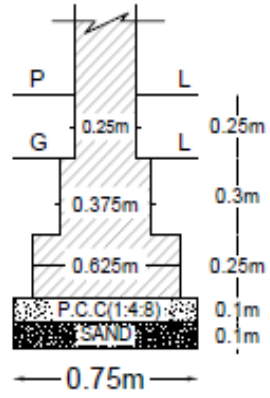

FOUNDATION

PROJECT PROPOSAL BRIEF

Verticals	ISSR	AHP	BLC (New)	BLC (E)	Remarks
▪ No. of Projects	-	-	23	-	
▪ No. of DUs	-	-	4849	-	
▪ Project Cost (In lakhs)	-	-	14588.16	-	
▪ Central Share	-	-	7273.50	-	
▪ State Share	-	-	2424.50	-	
▪ ULB Share	-	-	00.00	-	
▪ Beneficiary Share	-	-	4885.16	-	

Verticals (Rs. Lakhs)	Per Unit Cost	Central Share	State Share	ULB Share	Benf. Share	Completion Time
▪ ISSR	-	-	-	-	-	-
▪ AHP	-	-	-	-	-	-
▪ BLC (N/E)	3.00	1.50	0.50	0.00	1.00	120 days

PROJECT PROPOSAL BRIEF

Checklist	Status (Y/N)
▪ Layout plan(as per NBC norms)	Yes
▪ SLAC/SLSMC approval/Minutes submitted	Yes, SLAC on 19-05-2018 SLSMC on 21-05-2018
▪ Land title status (encumbrance free)	Yes
▪ Beneficiary list (BLC) submitted	Yes
▪ No. of Beneficiaries with Aadhar ID	4849
▪ No. of Beneficiaries with other Unique ID	-
▪ No. of Aadhar seeded Bank accounts	4849
▪ Status of physical & social infrastructure	Available in all ULBs
▪ Implementation plan/Completion period	120 days
▪ Beneficiary consent sought	Yes

Project Details of 23 projects under BLC

(Rs. In Lakhs)

SI No	ULB	Project Cost	Gol Grant	State Grant	ULB Share	Beneficiary Share	Unit Cost	Rs.@ Beneficiary	No of DUs proposed
1	Patnagarh	150.23	76.50	25.50	0.00	48.23	2.95	1.00	51
2	Titlagarh	228.00	114.00	38.00	0.00	76.00	3.00	1.00	76
3	Bargarh	999.36	432.00	144.00	0.00	423.36	3.47	1.05	288
4	Basudevpur	285.00	142.50	47.50	0.00	95.00	3.00	1.00	95
5	Chandabali	495.00	247.50	82.50	0.00	165.00	3.00	1.00	165
6	Chatrapur	171.00	85.50	28.50	0.00	57.00	3.00	1.00	57
7	Chatrapur	102.00	51.00	17.00	0.00	34.00	3.00	1.00	34
8	Chikiti	498.00	249.00	83.00	0.00	166.00	3.00	1.00	166
9	Digapahandi	144.00	72.00	24.00	0.00	48.00	3.00	1.00	48
10	Gopalpur	1044.00	522.00	174.00	0.00	348.00	3.00	1.00	348
11	Gopalpur	438.00	219.00	73.00	0.00	146.00	3.00	1.00	146
12	Hinjilicut	378.00	189.00	63.00	0.00	126.00	3.00	1.00	126
13	Hinjilicut	210.00	105.00	35.00	0.00	70.00	3.00	1.10	70
14	Kabisurya Nagar	201.00	100.50	33.50	0.00	67.00	3.00	1.05	67
15	Khalikote	168.00	84.00	28.00	0.00	56.00	3.00	1.00	56
16	Polasara	852.00	426.00	142.00	0.00	284.00	3.00	1.00	284
17	Jajpur	791.28	486.00	162.00	0.00	138.28	2.43	1.00	324
18	Keonjhar	475.20	270.00	90.00	0.00	115.20	2.64	1.00	180
19	Kotpad	1173.00	586.50	195.5	0.00	391.00	3.00	1.00	391
20	Konark	987.00	493.50	164.50	0.00	329.00	3.00	1.00	329
21	Pipili	1308.00	654.00	218.00	0.00	436.00	3.00	1.00	436
22	Pattamundai	2587.09	1216.50	405.5	0.00	965.09	3.19	1.00	811
23	Udala	903.00	451.50	150.50		301.00	3.00	1.00	301
	Total	14588.16	7273.50	2424.50	0.00	4885.16			4849

Status of JnNURM and RAY Projects

JnNURM at a Glance - BSUP



BSUP

01	Name of the Project	:	Basic Services to Urban Poor (BSUP)
02	No. of Mission Cities	:	Two
03	Total Project Cost Approved	:	Rs. 74.62 Cr
04	Total ACA Committed & Released	:	Rs. 54.18 Cr & Rs. 46.72 Cr (86.23%)
05	Total Amount with ULB/IA	:	Rs. 60.57 Cr (81.17%)
06	Total Expenditure made by ULB/IA	:	Rs. 48.61 Cr (80.25%)
07	Total UC Submitted Gol	:	Rs. 38.11 Cr. (78.39%)
08	Total DUs Approved (N+U)	:	2508 Nos.(2263 Nos. New DUs & 245Nos UG)
09	Total DUs Surrendered (N+U)	:	427 Nos. (232 Nos. New DUs & 195 Nos. UG)
10	Total DU s Completed & Occupied	:	1778 (85.43 %) & 1586 (76.21 %)
11	Total DU s under progress	:	31 (1.48 %)
12	DUs to be surrendered	:	272 (13.07%)

BSUP - ProjectWise Details



SI No	Name of the City / Project	DU Sanctioned (after deduction)	DU Completed	DU Progress	To be surrender
1	Puri – Matitota Mishra Nolia sahi	47	33	00	14
2	Puri Municipality Ph-II	170	127	31	12
3	BMC-Bhubaneswar Nayapalli SabarSahi	66	66	00	07
4	BMC-Bhubaneswar Dumuduma Raghunathpur	660	470	00	190
5	BMC-Bhubaneswar Bharatpur Vikashnagar	939	826	64	49
6	BDA-Bhubaneswar Damana & Gadakana	192	192	00	00
Total		2074	1667	169	272

JnNURM at a Glance - IHSDP



I H S D P

01	Name of the Project	:	Integrated Housing & Slum Development Programme (IHSDP)
02	No. of Projects	:	38 Nos.
02	No. of Towns/Cities Covered	:	35 Nos.
03	Total Project Cost Approved	:	Rs. 289.50 Cr
04	Total ACA Committed & Released	:	Rs. 194.53 Cr & Rs. 167.59 Cr (86.15%)
05	Total Amount with ULB/IA	:	Rs. 223.94 Cr (77.35%)
06	Total Expenditure made by ULB/IA	:	Rs. 187.57 Cr (83.75 %)
07	Total UC Submitted	:	Rs. 103.88 Cr. (55.38 %)
08	Total DUs Approved (N+U)	:	13097 Nos.(12821 Nos. New DU & 276 Nos UG)
09	DUs already Surrendered (N+U)	:	355 Nos. (All New DUs)
10	Total DUs Completed & Occupied	:	11,028 (86.54 %) & 10,572 (82.96 %)
11	Total DU s under progress	:	916 (7.18 %)
12	DUs to be surrendered	:	798 Nos (6.26%)

IHSDP - Project Wise Details



SI No	ULB	DU Sanctioned	DU Completed	DU Progress
1.	Angul	334	334	00
2.	Talcher	155	155	00
3.	Balesore (Ph-I)	162	162	00
4.	Balesore (Ph-II)	387	387	00
5.	Bargarh	732	552	10
6.	Bhadrak,Ph-I	238	208	06
7.	Bhadrak,Ph-II	166	117	13
8.	Bolangir	324	322	02
9.	Patnagarh	159	159	00
10.	Cuttack(Ph-II)	456	456	00
11.	Dhenkanal	608	506	82
12.	Paralakhemundi	307	174	14
13.	Berhampur	1202	1048	46

IHSDP - Project Wise Details



SI No	ULB	DU Sanctioned	DU Completed	DU Progress
14	Jajpur	295	295	00
15	Vyasnagar	1016	885	131
16	Brajarajnagar	177	177	00
17	Jharsuguda	786	753	33
18	Bhawanipatna	164	164	00
19	Kendrapara	87	85	02
20	Jatani(ph-I)	72	72	00
21	Jatani,Ph-II	132	118	14
22	Khurda	91	68	14
23	Keonjhar	261	240	21
24	Jeypore	323	270	20
25	Malkanagiri	236	192	22
26	Baripada	474	262	49

IHSDP - Project Wise Details



SI No	ULB	DU Sanctioned	DU Completed	DU Progress
27	Nayagarh	226	194	00
28	Nawarangpur	532	430	49
29	Khariar Road	305	305	00
30	Phulbani	157	124	33
31	Sambalpur	613	240	130
32	Kuchinda	177	177	00
33	Subarnapur	934	723	211
34	Biramitrapur	200	200	00
35	Rourkela	124	124	00
36	Boudhgarh	149	149	00
37	Joda	174	43	10
38	Jagatsinghpur	162	158	04
TOTAL		13097	11028	916

Photographs



**Dwelling Units
constructed
under BSUP**



Photographs of BSUP of Bhubaneswar



RAY -At a Glance



Scheme	Rajiv Awas Yojana
No of Projects	16 Nos
No of DUs sanctioned	11375 Nos (New – 9798, UG-1098 Nos & Transit House – 488 Nos)
DUs under progress	3841 Nos
DUs Completed	2433 Nos
Total Occupied	1091 Nos
Total ACA Received	Rs. 139.70 Cr.
Total UC submitted	Rs. 82.37 Cr.
Date of Completion	Dec 2018

Group Housing projects (G+4/ G+3 structures)



- ” Bhubaneswar: 4 projects
- ” Berhampur: 9 projects

City	No. of DUs sanctioned				Progress so far		
	Total	New	Up-gradation	Transit Houses	Completed	In Progress	Not Started
Bhubaneswar	3616	3232	0	384	1360	1400	856
Berhampur	5193	4367	826	0	244	1872	3321

Photograph



Mahishakhal Slum Improvement Project



Photographs



Patharabandha Slum Improvement Project

Photographs



Patharabandha Slum Improvement Project

Photographs



Niladri Vihar, BeMC, Berhampur

Photographs



Photographs



Anadasarani Slum, BeMC, Berhampur

Photographs



Group Housing projects in Berhampur and Bhubaneswar



Uttarmukhi site at Berhampur



Rangamatia site at Bhubaneswar

Individual Dwelling Units on owned plots



- ” Jajpur: 2 projects
- ” Cuttack: 1 project

City	No. of DUs sanctioned				Progress so far		
	Total	New	Up-gradation	Transit Houses	Completed	In Progress	Not Started
Cuttack	865	602	263	0	271	219	375
Jajpur	1701	1597	0	104	558	350	793

Individual Dwelling Units in Jajpur and Cuttack



Mundasahi at Cuttack



Issues with respect to RAY / JnNURM

- “ Status of UC submitted under Salary head of SLTC & CLTC under RAY.
- “ Status of UC submitted under project head of Jajpur ph-I, Mandap basti, Bhubaneswar and Berhampur Ph – I, II, III & IV under RAY.
- “ Status of reimbursement of fund for preparation of DPR and third party Monitoring (TPIMA) under JnNURM.

Thank You

Odisha Urban Housing Mission
Housing & Urban Development Department
371- AWAAS Building, Vivekananda Marg, Bhubaneswar-751014
Odisha

 @AWAAS.OUHM

 @OUHMAWAAS

 ouhmodisha@gmail.com