



**GOVERNMENT OF INDIA
MINISTRY OF HOUSING AND URBAN AFFAIRS**

**MANUAL ON
STORM WATER DRAINAGE SYSTEMS**

**VOLUME-I
PART A: ENGINEERING DESIGN
FIRST EDITION**

**CENTRAL PUBLIC HEALTH AND ENVIRONMENTAL ENGINEERING ORGANISATION
(CPHEEO)**

www.mohua.gov.in | www.cpheeo.gov.in

August, 2019



**GOVERNMENT OF INDIA
MINISTRY OF HOUSING AND URBAN AFFAIRS**

**MANUAL ON
STORM WATER DRAINAGE SYSTEMS**

VOLUME-I

PART A: ENGINEERING DESIGN

FIRST EDITION

**CENTRAL PUBLIC HEALTH AND ENVIRONMENTAL ENGINEERING ORGANISATION
(CPHEEO)**

www.mohua.gov.in | www.cpheeo.gov.in

August, 2019

In keeping with the advancements in the sector, updates as and when found necessary will be hosted in the Ministry website: <http://mohua.gov.in>, CPHEEO website: <http://cpheeo.gov.in> and the reader is advised to refer to these also.

All rights reserved.

No portion of this document may be reproduced / printed for commercial purpose without the prior permission of the Ministry of Housing and Urban Affairs, Government of India.

हरदीप एस पुरी
HARDEEP S PURI



आवासन और शहरी कार्य राज्य मंत्री (स्वतंत्र प्रभार)
नागर विमानन राज्य मंत्री (स्वतंत्र प्रभार)
वाणिज्य एवं उद्योग राज्य मंत्री
भारत सरकार
Minister of State (I/C), Housing & Urban Affairs
Minister of State (I/C), Civil Aviation
Minister of State, Commerce & Industry
Government of India

MESSAGE

Urban areas are engines of economic growth of the country. In India, cities are expected to contribute 75% of GDP by the year 2030. In recent years, increased frequency of urban flooding and consequent traffic snarls have adversely impacted our economy. Mumbai, Hyderabad, Chennai, Surat and Srinagar, have in recent times experienced floods which caused huge loss of life and property and had a devastating impact on the economy.

The Indian Monsoon is unique in that more than 80% of annual precipitation occurs in just 4 months i.e. between June and September, major part of which drains out as run-off and goes unused into the sea.

The Government of India has launched "Jal Shakti Abhiyan" with the main focus on water conservation, rainwater harvesting and reuse of wastewater. The Manual on Stormwater Drainage Systems prepared by the Central Public Health and Environmental Engineering Organization (CPHEEO), will give a fillip to the "Jal Shakti Abhiyan" and help the cities and towns in water conservation, protection from flooding and water security.

I would like to appreciate the efforts of the CPHEEO and members of the Expert Committee for their endeavour in bringing out this state-of-art Manual which will go a long way in transforming civic services in urban areas.

New Delhi
08 August 2019

(Hardeep S Puri)

दुर्गा शंकर मिश्र

सचिव

Durga Shanker Mishra

Secretary



सत्यमेव जयते



भारत सरकार
आवासन और शहरी कार्य मंत्रालय
निर्माण भवन, नई दिल्ली-110011
Government of India
Ministry of Housing and Urban Affairs
Nirman Bhawan, New Delhi-110011

FOREWORD

Urbanization is taking place at brisk pace in India. Urban development pattern has caused a major impact, in the prevailing run-off and it is very crucial that these issues are addressed in urban planning to promote effective solutions for maintaining water cycle and water resources in urban areas. Hence, an effective stormwater management shall lead to planned infrastructure development in the urban areas, thus ultimately resulting in efficient utilization of resources at large.

Global climate change is resulting in increased occurrences of irregular rainfall pattern and high intensity rainfall events on one hand, thereby, further aggravating the risk of flooding in towns and cities. On the other hand, there are certain cities in the country which are under water stress with people living under a constant threat of prolonged drought situation.

The absence of systematic approach to formulate and implement storm water drainage system, within specified planning horizon, has turned urban areas and cities vulnerable to inundation and frequent flooding. Further, inadequate operation and maintenance and the problem of encroachment of drainage pathway has further compounded the problem of urban flooding.

The present Manual on Stormwater Drainage System will assist the States/UTs/ULBs in planning, design, implementation, operations and maintenance of drainage systems.

The manual shall also work as a guidance document in recommending effective measures in water conservation, protection from flooding, enhancing water security in urban areas.

I congratulate CPHEEO, technical wing of our Ministry and PHE Division for putting in hard work and bringing out this pioneering Manual for reference to all stakeholders.

(Durga Shanker Mishra)

New Delhi
08 August, 2019

वी. के. जिन्दल
संयुक्त सचिव एवं मिशन निदेशक
V. K. JINDAL, ICoAS

Joint Secretary & Mission Director
Swachh Bharat Mission

Tel.: (011) 23061630
E-mail: vk.jindal@nic.in



सत्यमेव जयते



भारत सरकार
आवासन और शहरी कार्य मंत्रालय
निर्माण भवन

GOVERNMENT OF INDIA
MINISTRY OF HOUSING AND URBAN AFFAIRS
NIRMAN BHAWAN

नई दिल्ली-110011, तारीख 20
New Delhi-110011, dated the 20

PREFACE

Water and Sanitation is a top priority of the present Government. Various Missions implemented in the past decades have been focussing on Water Supply, Solid Waste Management and adequate Sanitation to the people in urban areas. Stormwater drainage often finds priority only after water supply, waste water and solid waste management, although, water security in cities is very much dependent on how efficiently we manage stormwater runoff locally.

With fast pace of urbanization and consequent imperviousness in the cities/towns, the problem of stormwater management has compounded, leading to frequent flooding and loss of lives and property. The coverage of stormwater drainage network stands about 20% of road network, as per 2011 census, which is quite inadequate to cater the stormwater management needs in the cities.

There was no comprehensive manual available for planning, design and management of stormwater runoff, except, a brief mention of rainfall analysis and runoff estimation given in Manual on Sewerage and Sewage Treatment published by Ministry in 2013.

CPHEEO, the Technical Wing of the Ministry, has prepared a comprehensive Stormwater Drainage Manual in three parts viz. Part A: Engineering design, Part B: Operation & Maintenance and Part C: Management which is contained in two volumes. Various design concepts are explained with suitable examples, which would be helpful to planners, engineers, designers and consultants working in Government institutions/urban local bodies/ consultancy organizations/academic institutions in planning and designing of urban stormwater drainage systems in the cities.

I thank Professor A K Gosain, Chairman of Expert Committee, Shri V K Chaurasia, Member Secretary, Dr Ramakant, Member Co-ordinator of the Expert committee and the whole CPHEEO and SBM team for working in coordination to complete this Manual. I also thank Shri R.K. Gupta, CMD WAPCOS and his entire team for their relentless work in finalization of this Manual.

All users of this manual may provide their feedback/suggestions for improvement in this manual

(V.K. JINDAL)

Place : New Delhi

Date : 14th August, 2019

Dr. M. DHINADHAYALAN

ADVISER (PHEE)

CPHEEO

Tel.: 011-23061926

Fax: 011-23062559

E-mail: adviser-pee-mhua@gov.in



सत्यमेव जयते



भारत सरकार

आवसान और शहरी कार्य मंत्रालय

GOVERNMENT OF INDIA

MINISTRY OF HOUSING AND URBAN AFFAIRS

NIRMAN BHAWAN

नई दिल्ली - 110011, तारीख

20

New Delhi - 110011, dated the 16-08-2019

EXECUTIVE SUMMARY

Urbanization is taking place at brisk pace in India. In the first decade of the 21st century, the number of towns increased from 5161 in the year 2001 to 7935 in the year 2011. The rapidly growing urbanization and the resultant uncontrolled change of the natural landscape have resulted in serious problems in many Indian cities. Many cities do not have a well-defined sewerage system and it is a common sight to see raw sewage flowing into the open storm drains, resulting in several adverse impacts. There has been gradual encroachment on the floodplains and on the banks of the storm water drains.

India has been witnessing devastating floods like Mumbai in the year 2005, Srinagar in 2014, the recent floods in Chennai and many parts of Kerala. These floods have inflicted irreparable loss to lives and properties apart from derailing the developmental pace of the city. Due to the lack of integrated drainage system, the larger cities are more prone to frequent flooding.

In India, more than 80 % of the annual precipitation occurs in just 4 months i.e. June to September, major part of which drains out as run-off and goes unutilized into the sea/water bodies. Global climate change is contributing to the increased occurrences of irregular and high intensity short duration rainfall events, thereby, further aggravating the risk of flooding in towns and cities.

Integrated planning right from the catchment to its final disposal including storage at feasible locations, adequate operation and maintenance, prevention of encroachment of drainage pathways needs to be considered. These would reduce to a considerable extent the vulnerability of the cities / towns to inundation and frequent flooding. Hence, an effective storm water management shall eventually lead to planned infrastructure development in the urban areas, resulting in efficient utilization of resources, especially in the water stressed cities in the country.

This Manual essentially spells out the need and approach for integrated planning, analysis of rainfall, runoff estimation, detailed engineering, construction, as well as, operation & maintenance and management of urban storm water drainage systems. This Manual recommends the implementation of a separate system of collection of sewage and stormwater, which is the prevalent practice in the developed world.

The manual is contained in three distinct parts over two volumes. Volume 1 contains Part A: Engineering Design; whereas Volume 2 contains Part B: Operation, Maintenance and Part C: Management.

Volume 1 - Part A: Engineering Design

- a. The need for preparation of the Manual including factors requiring due attention are contained in Chapter 1. Chapter 2 deals with project planning and investigation, data collection, survey, zoning & sub zoning of tributary catchments, alignment of major & minor conveyance system, location of inlets, outfall structures and environmental considerations etc.
- b. In the design of stormwater drainage system, past 30 years rainfall data obtained from Self Recording Rain Gauge Stations is analyzed to draw Intensity Duration Frequency (IDF) curves which is used for calculating the rainfall intensity corresponding to a given time of concentration that is useful in estimation of storm runoff. The procedure for drawing the IDF curve is mentioned in Chapter 3 and the methods for computation of storm runoff are described in Chapter 4.
- c. Climate change is one of the most important contributory factors to the increase in short duration high intensity rainfall and the consequent flooding. The design return period of rainfall events with a maximum of once in two years recommended in the Manual on Sewerage and Sewage Treatment published by CPHEEO in 2013 has been reviewed and after due deliberation, the design return period for class I cities is now recommended for once in 5 years and for other cities, once in 2 years. For airports and other critical infrastructures, the design return period is recommended as once in 100 years for Class I cities and once in 50 years for other cities. It is further recommended that under exceptional circumstances, a High Powered Committee which may be constituted by State/ UT Governments through a

notification may justify the adoption of higher return period from socio-economic and environmental angle. However, in case of flash floods, special structures like tunnels with necessary pumping arrangements may be proposed to bypass the flood water under the extreme circumstances.

- d. The US EPA Storm Water Management Model (SWMM) which is essentially used as a design aid for storm water drainage system is explained in detail in the Manual with design example.
- e. The hydraulic design of close conduits and open channels are mentioned in Chapter 5. Design considerations for special areas like hilly and coastal terrains are delineated in detail in Chapter 6. The various factors to be considered in the structural design of underground rigid and flexible conduits are mentioned in Chapter 7. Urban storm water drainage system may encounter situations where gravity flow conditions may not be feasible either due to topographical configuration or tidal variations in coastal areas requiring pumping arrangements. The detailed design of pumping machinery, pump and sump chambers etc. are provided in Chapter 8.
- f. The ever increasing urban runoff primarily due to growing size of urban areas, rampant paving of urban spaces and global warming induced climate change have posed new challenges before city authorities. In order to address these issues and to control the runoff at source itself to a certain extent, integration of rain water harvesting (RWH) systems are mentioned in Chapter 9.
- g. In today's urban centered growth, integration of innovative approaches for storm water management is getting prominence in city planning. Some developed countries are integrating smart practices such as Water Sensitive Urban Design (WSUD), Sustainable Urban Drainage System (SUDS), Low Impact Development (LID) and other Best Management Practices (BMPs) in their urban planning to economize storm water management on one hand and water security to the cities on another hand. A brief description of these approaches is mentioned in Chapter 10.

- h. The method of construction of storm water drains and conduits such as laying and jointing, types of construction materials and construction of appurtenant structures etc. have been provided in Chapter 11.

Volume II - Part B: Operation & Maintenance

This part of the Manual mentions the need for O & M, components of storm water drainage system like drains, conduits, manholes, etc. including its inspection and maintenance procedures, maintenance of pumps and motors in pumping stations, recharge structures, etc. It also lists the routine preventive maintenance, inspection program, closed circuit television surveys, desilting, trenchless technology for replacement, laying and repairing of conduits etc.

Volume II- Part C: Management

This part of Manual provides guidance on institutional arrangement, capacity building and training, public awareness through various mechanisms, financial management for sustainable operation & maintenance. A few revenue generation models have also been described for ensuring sustainability of storm water drainage systems.



Dr. M. Dhinadhayan

V K CHAURASIA
JOINT ADVISER
CPHEEO



सत्यमेव जयते



आवास और शहरी कार्य मंत्रालय

भारत सरकार
आवसान और शहरी कार्य मंत्रालय
GOVERNMENT OF INDIA
MINISTRY OF HOUSING AND URBAN
AFFAIRS
NIRMAN BHAWAN

नई दिल्ली - 110011, तारीख 20

New Delhi - 110011, dated the 16-08-2019

ACKNOWLEDGEMENT

The fast pace of urbanization in the country, inter-alia, has posed a challenge to beneficially manage storm water linking it to water security to the people in urban areas. Although, our country has the second largest urban population in the world, there was no dedicated stormwater drainage manual. Realizing the necessity of having a state-of-art Manual of Storm Water Drainage Systems, Ministry constituted an Expert Committee under the Chairmanship of Dr. A.K. Gosain, Professor Emeritus, IIT Delhi and drawing another 24 members from various areas including Government, Academic Institutions, Research Institutions and Field Practitioners (List of Expert Committee Members annexed). Ministry also engaged WAPCOS Limited to prepare draft contents of manual and provide secretarial support to the Expert Committee. The committee held 6 Expert Committee meetings and another 7 Working Group meeting followed by a National Consultation Workshop of the stakeholders for finalizing the Manual. The draft manual was also circulated to all stakeholders to seek their feedback/comments from users/field engineers/NGOs/academic institutions.

It gives us immense pleasure to complete the manual which would be used as a guiding document by all stakeholders in Planning, Design and Operation & Maintenance of Storm Water Drainage Systems across the country. I take this opportunity to thank Dr. A.K. Gosain, Professor Emeritus, IIT Delhi for steering all Expert Committee meetings and guiding all through the preparation of the manual, through his valuable insights. The contribution made by each and every member of the Expert Committee is well acknowledged. The contribution made by special invitees Professor Dr. Sadashiv Murthy BM, S J C E Mysore and Dr S Sundaramoorthy, Former Engineering Director, Chennai Metro Water Board are well appreciated.

I express my gratitude to the leadership of Shri Hardeep S. Puri, Hon'ble Minister of State (Independent Charge), Ministry of Housing and Urban Affairs for his efforts to bring at fore the water sector and particularly encouraging us to work for water security to people in the country. The storm water management approach suggested in the manual will go a long way in addressing the water security concerns in urban areas of the country.

I am also very thankful to Shri Durga Shanker Mishra, Secretary (HUA), Ministry of Housing and Urban Affairs for his vision in enriching the manual and make it more user friendly. His motivation and constant guidance all along in the preparation of the manual has been of immense help.

I also express my profound gratitude to Shri V.K. Jindal, Joint Secretary and Mission Director (SBM& PHE), Ministry of Housing and Urban Affairs for his impetus and all round support to complete the manual at the earliest. His regular and insightful guidance at all stages of preparation of manual has been of tremendous help.

I also thank Dr. M. Dhinadhayan, Adviser(CPHEEO), for providing important technical inputs for enriching the contents of the manual. His valuable guidance and efforts put-in, in reviewing various aspects of manual and improving its contents is highly appreciated.

I thank Dr. Ramakant, Deputy Adviser(PHE) and Member Coordinator of the Committee for coordinating activities and leading Manual to its completion. I thank my colleagues Shri J.B. Ravinder, Deputy Adviser(PHE), Shri Rohit Kakkar, Deputy Adviser(PHE) and Smt. K. Sravanthi Jeevan, Assistant Adviser(PHE) and other officers of CPHEEO for their useful contribution in preparation of the Manual and all round support. I also thank Dr. S. Saktheeswaran, Waste Management Expert, and other Experts/Consultants working in CPHEEO for providing technical assistance in completion of the manual.

I would also like to thank PHE &SBM Divisions and their entire team for providing administrative support for completing this manual. The efforts of SBM(PMU) at various stages of preparation of the manual is appreciated.

I would also like to express my sincere thanks to Mr R K Aggarwal, Mr M A Khan, Mr A P Sinha and Ms Shuchi Mishra and the entire WAPCOS team for drafting contents of manual and incorporating comments/suggestions to further enrich the manual leading to its completion. Their efforts to convene meetings and create hassle free environment for the Expert Committee members to scrutinize the contents of manual is well acknowledged.

With best wishes.



(V.K. CHAURASIA)

List of Members of Expert Committee as per Committee Constituted.

Sl. No.	Name	Designation
1.	Prof. A.K. Gosain, Ph.D. Professor, Department of Civil Engineering Indian Institute of Technology Delhi	Chairman
2.	Shri R. Sethuraman Ex-Joint Adviser (PHEE), CPHEEO	Member
3.	Prof.Kapil Gupta, Ph.D. (Sheffield, U.K.) Professor, Department of Civil Engineering Indian Institute of Technology Bombay	Member
4.	Prof. Arup Kumar Sharma Professor & Head, Department of Civil Engineering Indian Institute of Technology Guwahati	Member
5.	Prof. Deepak Kashyap Professor & Head, Department of Civil Engineering Indian Institute of Technology Roorkee	Member
6.	Shri S.V.R. Srinivas I.A.S AMC (ES), Municipal Corporation of Greater Mumbai	Member
7.	Shri Bigyan Kumar Beuria Asst. Engineer, Drainage Division, Puri Sub Division	Member
8.	Shri Bharat.I.Dalal Additional City Engineer(Civil),Surat Municipal Corporation	Member
9.	Shri K.C.Umesh Executive Engineer, Storm Water Drainage, Bruhut Bangalore Mahanagara Palike	Member
10.	Shri P. Rajendran Executive Engineer, Storm Water Drain Department Corporation of Chennai	Member
11.	Shri Nilangsu Bhusan Basu Principal Chief Engineer(Civil) Planning & Development Department, Kolkata	Member
12.	Dr. Pradeep Kumar Khandelwal Chief Engineer ,East Delhi Municipal Corporation.	Member
13.	Shri S. K. Jain Executive Engineer, Kanpur Road, Lucknow.	Member
14.	Shri Repang Longkumer	Member

Sl. No.	Name	Designation
	S.E. (M&I) O/O Chief Engineer (PHED), Kohima	
15.	Shri M.Raghuram Director,Hydrology (DSR) Directorate, Cental Water Commission	Member
16.	Dr. M. Dhinadhayalan, Joint Adviser (PHEE), CPHEEO, Ministry of Urban Development	Member
17.	Shri J.B.Ravinder , Deputy Adviser (PHE), CPHEEO, Ministry of Urban Development	Member
18.	Shri Chandrani B.Neogi National Institute of Disaster Management	Member
19.	Dr. Susanta Kumar Jena Senior Research Officer National Disaster Management Authority	Member
20.	Prof.R V Patil, Deputy Director, Indian Road Congress (IRC) , New Delhi	Member
21.	Dr. Rakesh Kumar Scientist 'G' & Head ,Surface Water Hydrology Division National Institute of Hydrology, Roorkee	Member
22.	Dr. Surinder Kaur Deputy Director General of Meteorology (H) O/O Director General of Meteorology	Member
23.	Shri Anik Roychowdhury Chief Engineer (Retd.), KMW&SA	Member
24.	Shri V.K. Chaurasia, Joint Adviser (PHEE), CPHEEO Ministry of Urban Development	Member Secretary
25.	Dr. Ramakant Assistant Adviser (PHE), CPHEEO Ministry of Urban Development	Member Coordinator

TABLE OF CONTENTS

TABLE OF CONTENTS	i
LIST OF TABLES	xi
LIST OF FIGURES	xiv
GLOSSARY	xvii
SYMBOLS AND ABBREVIATION	xxiv
CHAPTER 1: INTRODUCTION	1
1.1 General	1
1.2 Status of Urban Drainage System in India	2
1.3 Causes of urban flooding	3
1.4 Need for Storm Water Drainage Manual	4
1.5 Scope of Manual	4
1.6 Use of Manual.....	6
CHAPTER 2: PROJECT PLANNING AND INVESTIGATION	7
2.1 General	7
2.2 Objectives of Planning & Investigation	7
2.3 Data Collection, Survey and Investigation	8
2.3.1 Data Collection.....	9
2.3.2 Survey and Investigation.....	11
2.4 Planning of Storm Water Drainage Systems.....	12
2.4.1 Demarcation of Catchment and Planning Areas	12
2.4.2 Hydraulic Design of Storm Water Drainage Systems.....	13
2.4.2.1 Inlet locations	13
2.4.2.2 Manholes (MHs) and its locations	14
2.4.2.3 Pumping of storm runoff	14
2.4.2.4 Outfall Structures.....	15
2.5 Other Considerations	15
2.5.1 Permissions and Clearances	15
2.5.2 Environmental Consideration	15
2.6 Financing	16
2.7 Operation & Maintenance	17
2.8 Citizen Awareness	18
2.9 Institutional Arrangement and Capacity Building	18

Part A: Engineering Design

2.10	Service Level Benchmark	18
2.11	Incorporation of storm water drainage indices in the hydraulic design of storm water drains and its O & M.....	18
2.12	City Drainage Master Plan	19
2.13	Preparation of Reports.....	20
2.13.1	Preparation of DPR.....	20
2.13.1.1	Executive Summary	20
2.13.1.2	Introduction	20
2.13.1.3	Project Planning Area.....	21
2.13.1.4	Existing situation	21
2.13.1.5	Proposed Project and detailed design.....	21
2.13.1.6	Environmental Impact Assessment	22
2.13.1.7	Cost Estimation	22
2.13.1.8	Implementation Schedule.....	23
2.13.1.9	Conclusions and Recommendations	23
2.13.1.10	Checklist for DPR preparation.....	23
CHAPTER 3:	RAINFALL ANALYSIS.....	24
3.1	General	24
3.2	Rainfall.....	24
3.2.1	Measurement of Rainfall	24
3.2.1.1	Tipping Bucket Type Rain Gauge.....	25
3.2.1.2	Weighing Bucket Type Rain Gauge	25
3.2.1.3	Floating or Natural Syphon Type Rain Gauge.....	26
3.3	Rain Gauge Density.....	27
3.4	Rainfall Analysis	27
3.4.1	Steps for Analysis of Rainfall	28
3.4.2	Other Method of Rainfall Analysis.....	38
3.5	Probabilistic Method.....	40
3.5.1	Normal Distribution and Log Normal Distribution	40
3.5.2	Gumbel Extreme Value Distribution.....	40
3.5.2.1	Construction of IDF curve by Gumbel Distribution method.....	41
3.5.3	Log Pearson Type III Distribution.....	43
3.5.3.1	Construction of IDF curve by Log Pearson type III method	46
3.6	Translation of IDF curve into rainfall hyetograph	47

CHAPTER 4: RUNOFF ESTIMATION	49
4.1 General.....	49
4.2 Storm Runoff.....	49
4.3 Factors affecting runoff	50
4.4 Methods of Runoff Estimation.....	50
4.4.1 Rational Method.....	50
4.4.1.1 Steps of computation for Rational Method	50
4.4.1.2 Design flow.....	51
4.4.1.3 Procedure for estimation of runoff	51
4.4.1.4 Design Return Period	52
4.4.1.5 Runoff Coefficient.....	53
4.4.1.6 Time of Concentration in storm drainage system (tc)	54
4.4.1.6.1 Time of surface flow (t ₀)	54
4.4.1.6.2 Time of flow (t _f).....	55
4.4.1.7 Partial Area Effect	55
4.4.2 Time Area Method	57
4.4.2.1 Travel Time	57
4.4.3 Unit Hydrograph Method.....	59
4.4.3.1 Limitations of Unit Hydrograph	60
4.4.4 Rainfall- runoff process simulation	60
4.4.4.1 Kinematic Wave Equation	60
4.4.4.2 Non Linear reservoir method	62
4.5 Climate Change effects on Urban Storm Runoff	63
CHAPTER 5: HYDRAULIC DESIGN OF STORM WATER DRAINS	65
5.1 General.....	65
5.2 Storm water flows in Channels and Conduits	65
5.3 Design consideration for storm water drains.....	69
5.3.1 Permissible limit of Velocity	69
5.3.2 Freeboard in open channel	70
5.3.3 Curves/bends in drains	71
5.3.4 Junction Sump for storm water drain intersection	71
5.3.5 Hydraulically Efficient Channel Section.....	71
5.3.6 Partially Filled Circular Section	74
5.4 Design Sheet	77

Part A: Engineering Design

5.5	Gutters and Inlets.....	82
5.5.1	Gutter.....	82
5.5.2	Design of Gutters.....	82
5.5.3	Composite Gutter Sections.....	84
5.6	Storm water inlets.....	86
5.6.1	Types of inlets.....	86
5.6.2	Design of Inlets.....	88
5.6.3	Location of inlets.....	89
5.7	Gradually Varied Non-uniform Flow.....	91
5.7.1	Basic equation for gradually varied flow.....	92
5.7.2	Method of solution of the gradually varied flow equation.....	92
5.7.2.1	Direct Step Method.....	92
5.7.2.2	Standard Step Method.....	96
5.8	Rapidly Varied Non – Uniform Flow.....	96
5.8.1	Energy Dissipation.....	97
5.8.2.1	Stepped Channel.....	97
5.8.2.2	Chute.....	97
5.8.2.3	Aprons.....	98
5.8.2.4	Afflux.....	98
5.8.2.5	Loss of Energy in Hydraulic Jump.....	98
5.9	Hydraulic routing.....	100
5.10	Engineered Channels.....	102
5.10.1	Curvature and Super Elevation.....	103
5.10.2	Freeboard.....	103
5.10.3	Modification of Natural Channels.....	103
CHAPTER – 6: DESIGN CONSIDERATIONS FOR SPECIAL AREAS.....		105
6.1	General.....	105
6.2	Hilly Terrain.....	105
6.2.1	Impact of Erosion and Sedimentation on performance of storm water drains	105
6.2.2	Additional Design considerations for drainage systems.....	105
6.2.3	Temporary erosion and sedimentation control practices.....	107
6.3	Coastal Terrain.....	115
6.3.1	Design Considerations for storm water drainage in Coastal Areas.....	115

Part A: Engineering Design

6.3.2	Storm outfalls in coastal towns/cities	116
6.3.3	Sea levels in different conditions	116
6.3.4	Global trend in sea level variation	118
6.3.5	Regional trend in sea level variation.....	119
6.3.6	Design considerations for tidal outfall in ocean and bays.....	119
6.3.7	Design consideration for outfall in tidal rivers and streams	119
6.3.8	Design tail water level for non-tidal storm outlets	120
6.3.9	Outfall Structure.....	120
6.3.10	Backflow control Systems.....	121
6.3.10.1	Flap Gates and Flood Gates	121
6.4	River bank protection	122
CHAPTER 7: STRUCTURAL DESIGN OF BURIED STORM WATER CONDUITS		
.....		123
7.1	General	123
7.2	Type of Buried Pipes.....	123
7.2.1	Design of buried rigid pipe	123
7.2.2	Design method of buried flexible pipe	123
7.2.2.1	Deflection in flexible pipe.....	123
7.2.2.2	Buckling Pressure	129
CHAPTER – 8: STORM WATER PUMPING		133
8.1	General	133
8.2	Planning of Pumping Station.....	133
8.2.1	Location of the Pumping Point	134
8.2.2	Pump sump.....	134
8.2.3	Storage Reservoir	134
8.2.4	Power Source	134
8.2.5	Electrical & Mechanical Equipment.....	134
8.2.6	Access to site.....	135
8.2.7	Aesthetics of pumping station	136
8.2.8	Environmental Quality.....	136
8.2.8.1	Air Quality.....	136
8.2.8.2	Noise	136
8.3	Design of Pumping Station	136
8.3.1	Type of pump stations.....	136

Part A: Engineering Design

8.3.1.1	Wet pit pump station.....	137
8.3.1.2	Dry pit pump station	137
8.3.1.3	Trash Screens.....	138
8.3.2	Choice of Pump Type	139
8.3.3	Design of wet pit	139
8.3.4	Design Capacity of storage tank.....	140
8.3.5	Pump Characteristic Curves	141
8.3.5.1	System Curve.....	141
8.3.5.2	Pump curve.....	142
8.3.6	Net Positive Suction Head Required (NPSHr)	142
8.3.6.1	Vapour Pressure and Cavitation.....	144
8.3.6.2	Calculating Net Positive Suction Head Available (NPSHa)	144
8.3.6.3	Guidelines on NPSHr	145
8.3.7	Electrical Motors (prime mover)	145
8.3.7.1	Motor Rating.....	145
8.3.7.2	Voltage rating	146
8.3.8	Transformer Substation	147
8.3.8.1	Transformer Rating	147
8.3.8.2	Improvement of Power Factor	148
8.3.8.3	Lighting.....	148
8.3.8.4	Ventilation	149
8.3.9	Pumping main.....	149
8.3.9.1	Friction flow formula to size Pumping Mains	150
8.4	Flow Measurement	152
8.4.1	Measurement of flow in open Channels.....	152
8.4.1.1	Rectangular Notches.....	152
8.4.2	Measurement of flow in Closed Conduits.....	153
8.4.2.1	Differential Pressure Devices	153
8.4.2.1.1	Venturi Meters.....	154
8.5	Storm water Storage Pond/Basins.....	155
8.5.1	Detention ponds/Basin.....	155
8.5.2	Retention ponds/Basin.....	155
8.5.2.1	Site Selection	155
8.5.2.2	Adequacy of the site size	155

Part A: Engineering Design

8.5.2.3	Topographic consideration	155
8.5.2.4	Access to the site	156
8.5.3	Design of storm water Storage Pond/Basin	156
8.5.4	Optimization of Detention Tank/ Basin Capacity	156
8.5.5	Basin outlet	157
CHAPTER 9: INTEGRATION OF RAINWATER HARVESTING IN STORM WATER DRAINAGE DESIGN		158
9.1	General	158
9.2	Integration of rainwater harvesting & recharge systems with storm water drainage design	158
9.3	Rainwater harvesting techniques	158
9.3.1	In-situ storage / percolation.....	158
9.3.1.1	Roof top rainwater collection potential.....	159
9.3.1.2	Percolation of runoff into ground	163
9.3.1.2.1	Percolation pits	163
9.3.1.2.2	Percolation trenches	164
9.3.1.2.3	Recharge wells	165
9.3.2	Storage of runoff in nearby percolation pond / water tank.....	165
9.3.3	Percolation of storm water inside/outside the drains along its stretch....	166
9.3.4	Spreading water for recharge in low lying areas and park/gardens etc..	166
9.3.5	Disposal to water body.....	167
9.4	Precaution to be considered for harvesting of storm water	167
9.5	Pollution of Storm Water and its Treatment	167
9.5.1	Targeted Pollutants.....	169
9.5.2	Treatment methods for urban storm runoff	170
9.5.2.1	Sand Filters	170
9.5.2.2	Water Quality Inlets	172
9.5.2.3	Filter Strips	173
CHAPTER 10: INNOVATIVE STORM WATER MANAGEMENT PRACTICES		174
10.1	General	174
10.2	Innovative Storm Water Management Practices	174
10.2.1	Water Sensitive Urban Design (WSUD).....	174
10.2.1.1	Objective of WSUD	175
10.2.1.2	Integration of WSUD in Urban planning and Implementation	176
10.2.2	Low Impact Development Design	183

Part A: Engineering Design

10.2.2.1	Objectives of Low Impact Development	186
10.2.2.2	Approach for Planning & Implementation of LID.....	186
10.2.3	Sustainable Drainage System (SuDS)	189
10.2.3.1	Objective of SuDS	190
10.2.3.2	Steps for Design & Implementation of SuDS.....	190
10.2.3.3	Benefits of SuDS	193
10.2.4	Storm water Management and Road Tunnel (SMART tunnel).....	193
10.2.5	Decentralized Innovative intervention in storm water drainage designs.	193
CHAPTER 11:	CONSTRUCTION OF STORM WATER DRAINS	201
11.1	General	201
11.2	Implementation of the project.....	201
11.2.1	Pre-construction stage	201
11.2.2	Construction stage	202
11.3	Construction of Storm water conduits	202
11.3.1	Removal of pavement.....	203
11.3.2	Trench Preparation	203
11.3.2.1	Dimensions.....	203
11.3.2.2	Excavation.....	203
11.3.2.3	Shoring/Mild steel sheet piling.....	204
11.3.2.4	Underground services	204
11.3.2.5	Dewatering	204
11.3.2.6	Floatation of Flexible pipe	204
11.3.3	Pipe Bedding for rigid pipes	205
11.3.3.1	Type of Bedding	205
11.3.3.2	Classes of Bedding for Trench Conditions	206
11.3.4	Bedding of Flexible pipe.....	208
11.3.5	Laying of Rigid Storm water conduit	208
11.3.6	Laying and Jointing of Flexible pipe.....	209
11.3.6.1	Laying.....	209
11.3.6.1.1	For shallow trenches	209
11.3.6.1.2	Deep trenches with shoring/mild steel sheet Piling.....	209
11.3.6.2	Jointing.....	209
11.3.6.2.1	Jointing different pipe types or sizes.....	210
11.3.6.3	Manholes and Catch Pit Connections	210

Part A: Engineering Design

11.3.6.4	Conduit Connections	210
11.3.6.5	Type of pipe material and jointing of storm conduits (rigid pipe).....	210
11.3.6.5.1	Reinforced Cement Concrete Pipes (R.C.C Pipes)	210
11.3.6.5.2	Cast –In Situ Reinforced Concrete Pipes	211
11.3.6.6	Type of pipe material and jointing of storm conduits of Flexible pipe 211	
11.3.6.6.1	HDPE Pipes.....	211
11.3.6.6.2	UPVC Pipes.....	211
11.3.6.6.3	Glass fiber reinforced plastic pipes (GRP PIPES)	212
11.3.6.6.4	Structured Wall PE pipe	212
11.3.6.7	Backfilling of the Trenches of Rigid pipes.....	212
11.3.6.8	Construction of Backfill Envelope and Backfilling of the Trenches of Flexible pipe.....	213
11.3.6.9	Removal of sheeting or bracing.....	213
11.3.7	Storm water conduit appurtenant Structures.....	213
11.3.7.1	Manhole	214
11.3.7.2	Construction of Manholes.....	214
11.3.7.3	Location of Manholes	215
11.3.7.4	Spacing of Manholes.....	215
11.3.7.5	Drop-in Manhole.....	216
11.3.7.6	Shape and Size of the Manhole	216
11.3.7.7	Cover and Frame of Manhole.....	219
11.3.7.8	Access Steps in Manhole	220
11.3.7.9	Intermediate Platform	220
11.3.7.10	Inverts and benching.....	220
11.3.7.11	Outfall Structure	221
11.3.7.12	Inverted Syphon	221
11.3.7.13	Over Flow Device.....	222
11.3.7.14	Multi-Functional storm and Sewer Drains	223
11.4	Storm water Open Channel	224
11.4.1	Construction of Storm Water Drains	224
11.4.1.1	RCC drains.....	224
11.4.1.2	Brick Drains.....	224
11.4.1.3	Rectangular Section	225
11.4.1.4	Trapezoidal section	225

Part A: Engineering Design

11.4.2	Kerb and Gutter	225
11.4.3	Construction Procedures of Storm Water Drains	225
11.4.4	Covering of Drains	226
11.4.5	Box Drains	226
11.5	Drainage standards of Flyovers	227
11.5.1	Drainage at Foot of Flyovers.....	227
11.6	Vehicular Subways	227
11.7	Culverts.....	228
11.8	Safety and Social Safeguard	228
11.9	Completion of Works.....	229
11.10	Procedures for Handing Over	229
11.10.1	Procedure for handing Over in Dry Conditions	230
11.10.2	Handing over Drainage Records.....	230
REFERENCES.....		232
APPENDICES.....		A-1 to A-92

LIST OF TABLES

Table 2.1 Performance Indicator	18
Table 2. 2 Parameters / Indicators	19
Table 3.1: Storm of intensities corresponding to duration	29
Table 3. 2: Sorted storms against intensity and duration.....	30
Table 3. 3: Sorted storms against intensity and duration.....	31
Table 3. 4: Number of storms after horizontal addition.....	32
Table 3. 5: Number of storms after vertical addition	33
Table 3. 6: Stepped line for number of storms for 5 year storm return period	34
Table 3. 7: Intensity Duration for Storm of once in 5 year	35
Table 3. 8: Log – log graph between Intensity Duration for Storm Return Period for once in 5 year	36
Table 3. 9: IDF for Storm of Once in a 5 Year	37
Table 3. 10: Rainfall Analysis of single storm.....	38
Table 3. 11: Number of storms of intensities against corresponding duration	39
Table 3. 12: Number of storms of intensity or more against corresponding duration	39
Table 3. 13: Maximum rainfall depth	41
Table 3. 14: Maximum annual series Rainfall Depth (mm).....	42
Table 3. 15: Computation using Gumbel distribution method.....	43
Table 3.16: Kz values for Pearson Type III distribution (Positive Skew).....	44
Table 3. 17: Kz values for Pearson Type III distribution (Negative Skew)	45
Table 3.18: Computation using Log Pearson type III method.....	46
Table 3. 19: Computation to prepare Hyetograph	48
Table 4. 1: Recommended Design Return Period for various types of urban catchments	52
Table 4. 2: Runoff co-efficient of various surfaces	53
Table 5. 1: Coefficient of roughness for channel flow for use in manning’s formula .	68
Table 5. 2: Design velocities to be ensured in gravity storm conduits/channels.....	70
Table 5. 3: Minimum Free Board for open channels	70
Table 5. 4: Proportions of Some Most Efficient Sections.....	71
Table 5. 5: Hydraulic Properties of circular sections for manning’s formula	75
Table 5. 6: Computation sheet for Storm Water Conduit.....	78
Table 5.7: Computation sheet for Storm Water Open Channel	80
Table 5. 8: Manning’s n for gutter flow	83

Part A: Engineering Design

Table 5. 9: Calculation of back water curve.....	94
Table 5. 10: Calculation of draw down curve.....	96
Table 5. 11: Design Guidelines for Engineered Channels.....	102
Table 5. 12: Freeboard in Engineered Channels.....	103
Table 6. 1: Mulch materials, application rates and specifications.....	108
Table 6. 2: Design considerations for tidal out fall.....	119
Table 6. 3: Design tail water level	120
Table 7. 1: Recommended Design Deflection Limits.....	124
Table 7. 2: Live Loads on Flexible Pipes.....	125
Table 7. 3: Average Values of Modulus of Soil Reaction E' for Initial Flexible Pipe Deflection.....	126
Table 7. 4: Value of constant (K).....	127
Table 7. 5: Nominal size, Minimum Mean Inside Diameters, Thickness of inside Layers and Socket Length	128
Table 7. 6: Physical properties of PE pipe.....	129
Table 8. 1: Vapour Pressure of Water	144
Table 8. 2: Atmospheric Pressure in mWC at different altitudes above MSL	145
Table 8. 3: Multiplying factor for motor rating	146
Table 8. 4: Selection of motor based on supply voltage.....	146
Table 8. 5: Protective enclosure and environment type of motors.....	147
Table 8. 6: Illumination Levels.....	149
Table 8. 7: Values of Roughness coefficient, C, in Hazen-Williams formula	151
Table 8. 8: Friction factor for fittings in pumping mains	152
Table 9.1: Availability of Rainwater through Roof Top Rainwater Harvesting	161
Table 9. 2: Sizing Rain Water pipes for Roof Surface area drainage	162
Table 9.3: Sources of Contaminants in Urban Storm Water Runoff	168
Table 9. 4: Median Event Mean Concentrations for different Urban Land Uses.....	169
Table 9. 5: Targeted Pollutant	170
Table 10. 1: WSUD Measures: Role, Focus, Site Conditions and Benefits.....	180
Table 10. 2: Decentralized Innovative intervention in storm water drainage designs	194
Table 11. 1: Minimum Trench Widths.....	203
Table 11. 2: Required minimum cover to prevent floatation	204
Table 11. 3: Type of bedding for storm water conduits.....	205
Table 11. 4: Selection of bedding for different depths and different diameters.....	206

Part A: Engineering Design

Table 11. 5: Recommended Maximum spacing of Manhole..... 215
Table 11. 6: Recommended invert Drop-in Manhole..... 216

LIST OF FIGURES

S. No.	Title	Pg. No.
	Figure 1.1: Adyar River flowing over the Saidapet Bridge in Chennai flood in 2015 ..	1
	Figure 1.2: Dumping of Solid Waste in Storm Water Drains.....	2
	Figure 1.3: Rehabilitation of Brick Combined Sewer in Kolkata	2
	Figure 1.4: Encroachment in storm water drains	3
	Figure 1.5: Plastic in Storm Water Drain	4
	Figure 2.1: Identify dumping of garbage points	9
	Figure 3. 1 Tipping bucket type rain gauge	25
	Figure 3. 2 Weighing Bucket Type Rain Gauge	26
	Figure 3. 3: Natural Syphon or Float Type Rain Gauge	26
	Figure 3. 4: SRRG Chart for 24 hrs	28
	Figure 3.5: IDF curve for 5 year Return Period	43
	Figure 3. 6: IDF curve from Log Pearson Type III	47
	Figure 3. 7: Hyetograph.....	48
	Figure 4.1: Different routes of runoff	49
	Figure 4. 2: Isochrones.....	57
	Figure 4. 3: Hyetograph.....	58
	Figure 4.4: Time area curve	58
	Figure 4.5: 30 min Unit Hydrograph	59
	Figure 4.6: Nonlinear reservoir model	62
	Figure 5. 1: Partially Filled Circular Section.....	74
	Figure 5. 2: Hydraulic – Element graph for circular storm water conduits	76
	Figure 5. 3: Hydraulic elements of circular storm water conduits that possess equal self-cleansing properties at all depths	76
	Figure 5. 4: Gutter and Inlet	82
	Figure 5. 5: Gutter section with uniform cross-slope	82
	Figure 5. 6: Typical gutter section—composite cross-slope	82
	Figure 5. 7: Section of Street Inlet.....	86
	Figure 5. 8: Plan of street inlet	87
	Figure 5. 9: Catch Basin.....	87
	Figure 5. 10: Examples of Subcritical & Supercritical Flow	91

Part A: Engineering Design

Figure 5. 11: Depth Distance Relationship (Back Water Curve).....	95
Figure 5. 12: Depth Distance Relationship (Draw Down Curve).....	96
Figure 5.13: Hydraulic Jump	97
Figure 5. 14: Concrete Channel	102
Figure 5. 15: Natural Channel	102
Figure 6. 1: Weep holes in a retaining wall.....	106
Figure 6. 2: Intercepting / Catch Water Drain on a Hill Slope	107
Figure 6. 3: Mulching.....	108
Figure 6. 4: Sediment Basin	109
Figure 6. 5: Check Dams.....	111
Figure 6. 6: Silt Fence	112
Figure 6. 7: Brush Barrier	113
Figure 6. 8: Diversion Dike	114
Figure 6. 9: Temporary Slope Drain	114
Figure 6. 10: Trench Drain	115
Figure 6. 11: Sea levels.....	116
Figure 6. 12: Storm Water channel outfall	120
Figure 6. 13: Storm Water Conduit outfall	121
Figure 7. 1: Bedding Angle.....	127
Figure 8. 1: Wet Pit Pump Station with vertical turbine pump.....	137
Figure 8. 2: Dry Pit Pump Station with horizontal centrifugal pump.....	138
Figure 8. 3: Inflow Hydrograph	141
Figure 8. 4: Operating point of the curve	142
Figure 8. 5: Change in Operating Point of Pump with the change in Water level in Suction Sump.....	142
Figure 8. 6: Change in operating point of the pump by operation of delivery valve	142
Figure 8. 7: Schematic Representation of NPSHr	143
Figure 8. 8: Inflow and Outflow Hydrograph	157
Figure 9. 1: Typical rooftop rainwater harvesting system	159
Figure 9. 2: Filter unit	160
Figure 9. 3: Percolation Pit.....	164
Figure 9. 4: Percolation Trench.....	164
Figure 9. 5: Recharge Wells.....	165
Figure 9. 6: rain water Collection through storm water drains	166

Part A: Engineering Design

Figure 9. 7: Water spreading in low lying area	167
Figure 9. 8: Cross-section schematic of sand filter compartment.....	171
Figure 9. 9: Cross-section schematic of peat-sand filter.....	171
Figure 9. 10: Water Quality Inlet.....	172
Figure 9. 11: Cross-section of Filter Strip	173
Figure 10. 1: Aspects of Water Sensitive Urban Design.....	175
Figure 10.2: Basic LID strategy	185
Figure 10. 3: LID planning and implementation Approach.....	187
Figure 10.4: SuDS Design Principles	189
Figure 10. 5: SuDS planning process.....	191
Figure 10. 6: SuDS Treatment Train	192
Figure 11. 1: Classes of bedding.....	207
Figure 11. 2: Rectangular Manhole	217
Figure 11. 3: Circular Manhole	218
Figure 11. 4: Drop Manhole.....	219
Figure 11. 5: Inverted siphon with minimum two barrels	222
Figure 11. 6: Leaping weir	223
Figure 11. 7: Box drain	226
Figure 11. 8: Subway Drainage.....	227

GLOSSARY

Axial flow pumps	Pumps that lift the water up a vertical riser pipe; flow is parallel to the pump axis and drive shaft; commonly used for low head, high discharge applications.
Bench	The elevated bottom of an access hole to help streamline flow through the structure.
Bypass flow	Flow which bypasses an inlet on grade and is carried in street or channel to the next inlet downgrade.
Check valves	Water tight valves used to prevent backflow.
Combination inlets	Use of both a kerb opening inlet and a grate inlet.
Convolution	The process of using the unit hydrograph to determine the direct runoff hydrograph from the excess rainfall hydrograph.
Cover	Distance from the outside top of the pipe to the final grade of the ground surface.
Critical flow	Flow in an open channel that is at minimum specific energy and has a Froude number equal to 1.0
Critical depth	Depth of flow during critical flow.
Cross slope	The rate of change of roadway elevation with respect to distance perpendicular to the direction of travel. Also known as transverse slope.
Crown	The inside top elevation of a conduit.
Kerb - opening inlet	A discontinuity in the kerb structure which is covered by a top slab.
Detention time	The time required for a drop water to pass through a detention facility when the facility is filled to design capacity.
Direct runoff	The stream flow produced in response to a rainfall event and is equal to total stream flow minus base flow.

Drainage inlets	The receptors for surface water collected in ditches and gutters, which serve as the mechanism whereby surface water enters storm drains; refers to all types of inlets such as grate inlets, kerb inlets, slotted inlets, etc.
Dry-pit stations	Pump stations that use both a wet well and a dry well. Storm water is stored in the wet well which is connected to the dry well by horizontal suction piping. The storm water pumps are located on the floor of the dry well.
Energy grade line (EGL)	The line that represents the total energy of flow at a given location. It is the sum of the elevation head, the pressure head, and the velocity head.
Extended Detention Dry ponds	Depressed basins that temporarily store a portion of the storm water runoff following a storm event. The extended detention time of the storm water provides an opportunity for urban pollutants carried by the flow to settle out.
Flap gates	A gate which restricts water from flowing back into the discharge pipe and discourages entry into the outfall line.
Flow line	The bottom elevation of an open channel or closed conduit.
Gate valves	Shut-off devices used on pipe lines to control flow. These valves should not be used to throttle flow. They should be either totally open or totally closed.
Grate inlets	Parallel and/or transverse bars arranged to form an inlet structure.
Gutters	Portion of the roadway structure used to intercept pavement runoff and carry it along the roadway shoulder.
Hydraulic grade line (HGL)	A line coinciding with the level of flowing water in an open channel. In a closed conduit flowing under pressure, the HGL is the level to which water would

	<p>rise in a vertical tube at any point along the pipe. It is equal to the energy grade line elevation minus the velocity head, $V^2/2g$.</p>
Hydraulic jump	<p>A flow discontinuity which occurs at an abrupt transition from to supercritical to subcritical flow.</p>
Hydraulic radius	<p>The hydraulic radius is the cross sectional area of the flow divided by the wetted perimeter. For a circular pipe flowing full, the hydraulic radius is one-fourth of the diameter. For a wide rectangular channel, the hydraulic radius is approximately equal to the depth.</p>
Hydrograph	<p>A plot of flow versus time.</p>
Hydrologic abstractions	<p>Losses of rainfall that do not contribute to direct runoff. These losses include water retained in surface depressions, water intercepted by vegetation, evaporation, and infiltration.</p>
Hyetographs	<p>A plot of rainfall intensity vs. time for a specific rainfall event. It is typically plotted in the form of a bar graph.</p>
Infiltration trenches	<p>Shallow excavations which have been backfilled with a coarse stone media. The trench forms an underground reservoir which collects runoff and exfiltrates it to the subsoil.</p>
Intensity	<p>The rate of rainfall typically given in units of millimeters per hour (inches per hour).</p>
Invert	<p>The inside bottom elevation of a closed conduit.</p>
Intensity-Duration Frequency Curves	<p>IDF curves provide a summary of a site's rainfall characteristics by relating storm duration and expedience probability (frequency) to rainfall intensity (assumed constant over the duration).</p>
Infiltration basins	<p>An excavated area which impounds storm water flow and gradually exfiltrates it through the basin floor.</p>

Junction boxes	Formed control structures used to join sections of storm drains.
Longitudinal slope	The rate of change of elevation with respect to distance in the direction of travel or flow.
Major system	This system provides overland relief for storm water flows exceeding the capacity of the minor system and is composed of pathways that are provided, knowingly or unknowingly, for the runoff to flow to natural or manmade receiving channels such as streams, creeks, or rivers.
Mass rainfall curve	The cumulative precipitation plotted over time.
Minor system	This system consists of the components of the storm drainage system that are normally designed to carry runoff from the more frequent storm events. These components include: kerbs, gutters, ditches, inlets, manholes, pipes and other conduits, open channels, pumps, detention basins, water quality control facilities, etc.
Mixed flow pumps	Mixed flow pumps are very similar to axial flow except they create head by a combination of lift and centrifugal action. An obvious physical difference is the presence of the impeller "bowl" just above the pump inlet.
Open channel	A natural or manmade structure that conveys water with the top surface in contact with the atmosphere.
Open channel flow	Flow in an open conduit or channel that is driven by gravitational forces.
Pressure flow	Flow in a conduit that has no surface exposed to the atmosphere. The flow is driven by pressure forces.
Radial flow pumps	Pumps that utilize centrifugal force to move water up the riser pipe. They will handle any range of head and discharge, but are the best choice for high head applications. Radial flow pumps generally handle debris quite well.

Retention/detention facilities	Facilities used to control the quantity, quality, and rate of runoff facilities discharged to receiving waters. Detention facilities control the rate of outflow from the watershed and typically produce a lower peak runoff rate than would occur without the facility. Retention facilities capture all of the runoff from the watershed and use infiltration and evaporation to release the water from the facility.
Routing	The process of transposing an inflow hydrograph through a structure and determining the outflow hydrograph from the structure.
Sand filters	Filters that provide stormwater treatment when runoff is strained through a sand bed before being returned to a stream or channel.
Shallow concentrated flow	Flow that has concentrated in rills or small gullies.
Shear stress	Stress on the channel bottom caused by the hydrodynamic forces of the flowing water.
Sheet flow	A shallow mass of runoff on a planar surface or land area in the upper reaches of a drainage area.
Slotted inlets	A section of pipe cut along the longitudinal axis with transverse bars spaced to form slots.
Specific energy	The energy head relative to the channel bottom.
Spread	A measure of the transverse lateral distance from the kerb face to the limit of the water flowing on the roadway.
Steady flow	Flow that remains constant with respect to time.
Stochastic / Probabilistic methods	Frequency analysis used to evaluate peak flows where adequate gaged stream flow data exist. Frequency distributions are used in the analysis of hydrologic data and include the normal distribution, the log-normal distribution, the Gumbel extreme value distribution, and the log-Pearson Type III distribution.

Storm water drain	A particular storm drainage system component that receives runoff from inlets and conveys the runoff to some point. Storm drains are closed conduits or open channels connecting two or more inlets.
Storm drainage systems	Systems which collect, convey, and discharge storm water flowing systems within and along the highway right-of-way.
Subcritical flow	Flow characterized by low velocities, large depths, mild slopes, and a Froude number less than 1.0.
Supercritical flow	Flow characterized by high velocities, shallow depths, steep slopes, and a Froude number greater than 1.0.
Synthetic rainfall events	Artificially developed rainfall distribution events
Time of concentration	The time for runoff to travel from the hydraulically most distant point in concentration the watershed to a point of interest within the watershed. This time is calculated by summing the individual travel times for consecutive components of the drainage system.
Total dynamic head	The combination of static head, velocity head, and various head losses in the discharge system caused by friction, bends, obstructions, etc.
Tractive force	Force developed by the channel bottom to resist the shear stress caused by the flowing water.
Unit hydrograph	The direct runoff hydrograph produced by a storm of given duration such that the volume of excess rainfall and direct runoff is 1 cm (1 inch).
Uniform flow	Flow in an open channel with a constant depth and velocity along the length of the channel.
Unsteady flow	Flow that changes with respect to time.
Varied flow	Flow in an open channel where the flow rate and depth change along the length of the channel.
Water quality inlets	Pre-cast storm drain inlets (oil and grit separators) that remove sediment, oil and grease, and large

particulates from paved area runoff before it reaches storm drainage systems or infiltration BMPs.

Weir flow

Flow over a horizontal obstruction controlled by gravity.

Wet-pit stations

Pump stations designed so that the pumps are submerged in a wet well or sump with the motors and the controls located overhead.

Wet ponds

A pond designed to store a permanent pool during dry weather.

Wetted perimeter

The wetted perimeter is the length of contact between the flowing water and the channel at a specific cross section.

SYMBOLS AND ABBREVIATION

1.	A	Catchment Area
2.	a	Cross-section of the partially filled circular section
3.	A_c	Smaller impervious tributary area to the larger drainage area
4.	ARG	Automatic Rain Gauge
5.	B	Width of water surface in the channel
6.	(B/C)	Benefit/ Cost Ratio
7.	BMP	Best Management Practices
8.	C	Runoff Coefficient
9.	C & D	Construction and Demolition Waste
10.	CCTV	Closed-circuit television
11.	CGWB	Central Ground Water Board
12.	CMP	City Master Plan
13.	CPCB	Central Pollution Control Board
14.	CPHEEO	Central Public Health and Environmental Engineering Organisation
15.	CPWD	Central Public Works Department
16.	C_s	Coefficient of Skewness
17.	CWA	Chester Water Authority
18.	D	Diameter of pipe
19.	D_L	Deflection lag factor
20.	D_M	Mean Diameter
21.	D_m	Hydraulic mean depth
22.	d_p	Particle size in mm
23.	DPR	Detailed Project Report
24.	E	Modulus of Elasticity
25.	E'	Modulus of Soil Reaction
26.	EIA	Environmental Impact Assessment
27.	EMCs	Event Mean Concentrations
28.	EPA	Environmental Protection Agency
29.	E_s	Specific energy
30.	ESRI	Environment System Research Institute

Part A: Engineering Design

31. f	Darcy Weisbach friction factor
32. F_r	Froude number
33. g	Acceleration due to gravity
34. GOD	Gang operated disconnectors
35. HAT	Highest Astronomical Tide
36. HFL	High Flood water level
37. H_{fs}	Friction losses
38. HUDCO	Housing and Urban Development Corporation Limited
39. H_s	Static head
40. H_f	Frictional head
41. H_v	Velocity head
42. H_l	Head loss in fittings and valves (m)
43. H_w	Height of groundwater over top of pipe
44. I	Intensity of Rainfall
45. IDF	Intensity Duration Frequency
46. IEC	Information, Education And Communication
47. IMD	India Meteorological Department
48. INCOIS	Indian National Centre for Ocean Information Service
49. IoF	Inspectorate of Factories
50. IPCC	Intergovernmental Panel on Climate Change
51. K_z	Frequency factor
52. L	Length
53. LAT	Lowest Astronomical Tide
54. LIC	Life Insurance Corporation
55. LID	Low Impact Development
56. MHs	Manholes
57. MHWN	Mean High Water Neaps
58. MHWS	Mean High Water Springs
59. MLWN	Mean Low Water Neaps
60. MLWS	Mean Low Water Springs
61. MSL	Mean Sea Level
62. mWC	Meters of Water Column
63. N	Manning's roughness coefficient for Overland flow
64. n	Manning's roughness coefficient of surfaces

Part A: Engineering Design

65.	NDMA	National Disaster Management Authority
66.	NDRF	National Disaster Response Force
67.	NIDM	National Institute of Disaster Management
68.	NODC	National Oceanographic Data Centre
69.	NPSHa	Net Positive Suction Head Available
70.	NPSHr	Net Positive Suction Head Required
71.	NURP	Nationwide Urban Runoff Program
72.	O & M	Operation and Maintenance
73.	OD	Outside diameter
74.	OSHA	Occupational Safety and Health Administration
75.	P	Wetted perimeter
76.	P_{cr}	Critical Buckling Pressure
77.	PPP	Public-Private Partnership
78.	P_s	Suction Pressure
79.	PS	Pipe Stiffness
80.	PSMSL	Permanent Service for Mean sea level
81.	P_v	Actual buckling pressure
82.	Q	Discharge
83.	Q_p	Peak flow
84.	q	Discharge from partially filled section
85.	R	Hydraulic Radius
86.	RCC	Reinforced Cement Concrete
87.	Re	Reynold's Number
88.	RRHS	Roof Top Rainwater Harvesting System
89.	RWH	Rain Water Harvesting
90.	R_w	Water buoyancy factor
91.	S	Surface Slope
92.	S_L	Longitudinal slope
93.	SMART	Stormwater Management and Road Tunnel
94.	SOR	Schedule of Rates
95.	SRRG	Self-recording Rain Gauge
96.	S_s	Specific gravity of particles
97.	SUDS	Sustainable Urban Drainage System
98.	SuDS	Sustainable Urban Drainage System

99. SWD	Storm Water Drainage
100. SWMM	Storm water Management Model
101. S_x	Cross slope, m/m
102. T	Storm Return Period
103. t	Rainfall Duration
104. t_c	Time of Concentration
105. t_f	Time of Flow
106. t_o	Time of surface flow
107. u	Mode of Distribution
108. ULB	Urban Local Body
109. UT	Union Territory
110. V	Velocity of Flow
111. V_p	Vapour pressure
112. WMO	World Meteorological Organization
113. WOCE	Water Ocean Circulation Experiment
114. WSUD	Water Sensitive Urban Design
115. W_c	Soil Column load
116. W_L	Live load
117. X	Rainfall Event
118. X_T	T Year Return Period Value
119. y	Depth of Flow
120. y_T	Reduced Variate
121. Z	Logarithmic Variates of X
122. Z_s	Potential energy
123. α	Sample Moments
124. ν	Kinematic Viscosity
125. π	Pi
126. σ	Standard Deviation
127. δ_t	Duration of n time Intervals
128. \bar{Z}	Mean of Z values
129. \bar{X}	Mean of X values
130. Y_w	Unit weight of water
131. Y_s	Soil density

CHAPTER 1: INTRODUCTION**1.1 General**

Urbanization is taking place at a brisk pace in India. In the first decade of the 21st century, the number of towns increased from 5161 (2001) to 7935 (2011). Similarly, the urban agglomerations are not only increasing in number, it is also getting larger in population and sprawling. The number of cities with a population of 1 million or more has increased from 35 in the year 2001 to 53 in year 2011. Majority of urban areas, be it large metropolis or small municipal town, severely lack effective storm water drainage facilities. Unplanned development coupled with encroachment of existing natural drainage corridors, waterways etc. exacerbates the problem of urban drainage. In the quest for extreme development, important environmental benefits from natural functionalities like waterways/water bodies are often ignored, overlooked, and compromised. This aspect, along with recent trends in climate change is also causing the rise in incidences of acute waterlogging, urban flooding, and related adverse economic and health impacts. Storm flows, if not regulated or routed to its convergence of safe disposal, may cause unprecedented degradation of urban infrastructure causing severe damage to life and property, depending on the degree of severity of storm event.

In recent years, frequency of urban flooding has increased, and the issue is getting more pronounced day-by-day due to its enormous socio-environmental hazards leading to traffic snarls and disruption in urban life. Some of the notable cases of flooding which caused devastating impact on economic loss as well as the loss of lives are urban flooding in Hyderabad (2001 and 2012), Delhi (2002, 2003, 2009, 2010 and 2011), Chennai (2004 and 2015), Mumbai (2005, 2008 and 2009), Kolkata (1978 and 2007), Surat (2006), Jamshedpur (2008), Guwahati (2010), Jaipur (2012), Jammu & Kashmir (2014) and recent devastation in Kerala (2018).



Figure 1.1: Adyar River flowing over the Saidapet Bridge in Chennai flood in 2015

To protect the urban areas against flooding in a phased manner, consistent with availability of resources, storm water drainage systems need to be planned and implemented in structured manner considering various aspects of design, operation & maintenance and economics. This essentially spells out the need for the formulation of this National Manual containing aspects of planning, rainfall analysis, designing, detailed engineering of facilities, construction, as well as, operation & maintenance of

urban storm water drainage systems including rehabilitation and refurbishing of prevailing under-performing drainage systems.

1.2 Status of Urban Drainage System in India

Urban storm water drainage systems have got priority in India only after drinking water supply and sewerage projects in the majority of the cases. Due to fast pace of urbanization and migration of people from rural areas to urban areas in quest of livelihood and better education, there has been immense pressure on urban infrastructure, worsening the problem of urban drainage systems in India. Some of the important factors responsible for present status of poor urban drainage system in India are as under:

1. The natural drainage systems in most of the cities are in jeopardy, and the problem of flooding is worsening with time due to non-availability of properly engineered storm water drainage infrastructures. The problems are exacerbated due to encroachment and rampant dumping of garbage & solid waste in the drains on one hand and absence of preventive maintenance on the other.



Figure 1.2: Dumping of Solid Waste in Storm Water Drains

2. The megalopolises (megacities) have a long history of municipal drainage perceptions since the British era. Most of the underground drainage facilities within core clusters of these megacities are usually century-old antiquated brick masonry conduits. The existing storm water collection network in these cities is mainly designed to serve as a combined system for sewage as well as storm water runoff. Augmentation and rehabilitation, including separation of storm water from sewage in such facilities, invite highest level of challenges for municipal engineers and financial resources.



Figure 1.3: Rehabilitation of Brick Combined Sewer in Kolkata

3. The coverage of storm water drainage network stands about 20% of road network and its allied catchments as per the report on Indian Urban Infrastructure and Services (March 2011), published by the erstwhile Ministry of Urban Development (MoUD) which is too inadequate to cater to the storm water disposal in the present city scenario.

1.3 Causes of urban flooding

Some of the major causes leading to frequent flooding even in light rainfall in urban areas of India are as under:

1. Many important cities in the country receive high average annual rainfall during four months of monsoon. The cities like Mumbai receive annual average rainfall of order of the 2,932 mm. High intensity rainfall in such cities is responsible for frequent flooding.
2. Storm drainage systems are currently designed in India for rainfall intensities of once in one year to once in two years return periods. In case, rainfall records are not available; rainfall intensity is usually adopted in the range of 12 mm/hr – 20 mm/hr. Therefore, 'Accommodation & Transportation' capacities of such hydraulically configured drainage facilities are easily overwhelmed, whenever rainstorms of higher frequencies are experienced.
3. Unplanned urbanization causes a considerable increase in impervious areas, thereby leading to enhanced surface runoff and frequent flooding.
4. The problem of disposal of storm runoff is compounded in the cities having flat terrain, tidal fluctuations in coastal areas and blockage of streams/drains due to landslides in hilly areas.
5. Global climate change resulting in the changed weather pattern and increased occurrence of high intensity rainfall events further aggravate the risk of flooding in towns and cities.
6. The absence of systematic approach to formulating and implement a holistic storm water drainage scheme within specified planning horizon has turned urban areas and cities so vulnerable now that even rain of light and medium intensity causes urban flooding.



Figure 1.4: Encroachment in storm water drains

7. The problem of illegal disposal of Construction and Demolition waste / municipal solid waste / plastic waste coupled with poor maintenance of existing drainage system often obstructs the storm runoff causing localized flooding in the areas.



Figure 1.5: Plastic in Storm Water Drain

1.4 Need for Storm Water Drainage Manual

In view of the existing status of drainage systems in urban areas, that causes frequent flooding leading to loss of property and life, it necessitates looking into the problem more closely and coming out with planning, designing, implementation and operation & maintenance guidelines to overcome the issues in urban areas.

It is worth mentioning that there is no dedicated reference document/ manual available on storm water drainage systems in India like the ones on Water Supply & Treatment Systems, 1999; Sewerage and Sewage Treatment Systems, 2013 and Municipal Solid Waste Management, 2016, all published by the Ministry of Housing and Urban Affairs, Govt. of India. Majority of the countries across the globe like Singapore, Hong Kong, Australia, United States of America, Malaysia, and many others have their manual on storm water drainage systems. The existing “Manual on Sewerage and Sewage Treatment Systems, 2013”, published by Ministry of Housing and Urban Affairs, Government of India, incorporates very few aspects of urban storm water management under its Section 3.9, but the same is grossly inadequate to address the issues related to storm water drainage.

Therefore, a comprehensive and exclusive manual on storm water drainage systems has become imperative to guide the public health engineers / municipal engineers/city planners and consultants across the country. Accordingly, this National Manual is formulated to provide necessary guidance towards all aspects of sustainable design, planning, and management of storm water drainage systems of towns and cities of the country.

1.5 Scope of Manual

This Manual is a guide book for hydrologic & hydraulic design of storm water drainage systems and includes, inter alia, planning, designing, detailed engineering, operation and maintenance of various components of urban storm water drainage systems. The appurtenant socio-environmental aspects are also an embedded component of the scope. The manual is contained in three distinct Parts over two volumes. Volume 1

contains Part A: Engineering Design, whereas Volume 2 contains Part B: Operation, Maintenance, and Part C: Management. A brief outline of these volumes is as follows:

Volume 1 - Part A: Engineering Design

The Volume 1 of Manual contains the planning and Engineering Design of various elements of storm water drainage systems and is organized in the following Chapters:

- **Chapter 1** deals with the issues of the urban drainage system in India and requirement of an exclusive Manual on Storm Water drainage Systems.
- **Chapter 2** covers the planning aspects of urban storm water drainage projects, related Investigation, data collection, survey inputs, and environmental as well as financial aspects.
- **Chapter 3** contains rainfall analysis and development of IDF curves using empirical and probabilistic methods.
- **Chapter 4** deals with runoff estimation resulting from urban catchments by various methods viz. rational method, time area method, unit hydrograph method, and rainfall-runoff simulation method.
- **Chapter 5** covers the hydraulic design of storm water drains with applicable flow equations.
- **Chapter 6** covers additional design considerations for special areas to be considered while designing storm water drains in hilly and coastal areas.
- **Chapter 7** deals with the structural design of storm water drains covering process design of underground rigid and flexible conduits for carrying storm water.
- **Chapter 8** covers the handling of storm water through pumping and deals with planning and design of pumping station for pumping of storm water.
- **Chapter 9** covers planning and design of rain water harvesting to be used for multiple purposes like artificial recharge of ground water and attenuation of flash floods.
- **Chapter 10** elaborates the methodology for using existing drains to allow excess runoff to percolate in the ground water. It also deals with various emerging practices adopted across the world for storm water drainage design such as Water Sensitive Urban Design (WSUD), Low Impact Development (LID) and Sustainable Urban

Drainage System (SUDS). Best Management Practices (BMPs) of storm water drainage system are also discussed briefly.

- **Chapter 11** covers construction aspects of storm water drains, and its appurtenant structures.

Volume 2: Operation, Maintenance and Management

The Volume 2 of the Manual is divided into two parts as briefly described below:

Part B: Operation and Maintenance, deals with operation & maintenance, inspection and replacement & rehabilitation of storm water drains.

Part C: Management deals with public awareness, capacity building, institutional arrangement and financial sustainability.

1.6 Use of Manual

This manual has been prepared for the purpose of assisting engineers, planners, designers, architects, geographers and hydrologists working in government / private institutions, urban local bodies, industrial and business concerns, consultancy services, etc., in planning and design of urban storm water drainage system in the country.

The manual aims to provide details of essential technical and engineering aspects considered during planning, design, and management of urban storm water drainage system and to provide details of appropriate design and computational procedures.

CHAPTER 2: PROJECT PLANNING AND INVESTIGATION**2.1 General**

The project planning and investigation is the backbone of project development and lays the foundation for its successful implementation and economical operation and maintenance. This chapter covers various aspects of project planning and investigation, data collection, survey, design considerations, environmental considerations, permission and clearances, guidelines for the preparation of DPR, provision for O & M, financial sustainability, etc. A checklist for preparation of DPR is also developed for objectively guiding DPR preparation and its vetting by the concerned authorities.

2.2 Objectives of Planning & Investigation

The objective of planning and investigation is to provide detailed information about the type and topography of the land, details of existing drains, land use pattern, networks of roads, culverts and railway lines, etc. which require due consideration in master planning / zonal planning/augmentation of the drainage system in the city. The following aspects need to be considered while planning & investigating for development of a drainage system:

- i. Identification and marking of Catchment areas
- ii. Identification and marking of probable drainage zones, the direction of gradients and selection of disposal points
- iii. Preparation of topographical layout of collection and conveyance
- iv. Storm water drainage plan should be separate from the sewerage system for all stages of planning and designing
- v. Identification of locations for pumping stations
- vi. Strategy for rainwater storage and its recharge to groundwater and disposal of excess storm water
- vii. Identification of stretches of drains / vulnerable points susceptible to the dumping of solid waste / C & D waste/encroachment/ choking point
- viii. Strategy for prevention of solid waste and C & D waste into storm waterways
- ix. Strategy for arresting pollutants with urban runoff from entering into water bodies
- x. Conserving the aesthetics, public safety and other social concerns of recreational open space and landscape to preserve the ecological nature of waterways
- xi. Identification of existing storm water drains / drainage corridors including age-old drainage conduits for rehabilitation

- xii. Non-structural and structural measures should be studied and components designed accordingly to provide relief during the occurrence of disasters due to flooding
- xiii. Frame a Road Map for Urban Storm Water Best Management Practices (BMP)
- xiv. Preparation of a strategy for protection of urban areas from flooding. This need to include any excess runoff likely to come to the city area from upper reaches. To attenuate flooding, the water storage ponds should be rejuvenated within city and also created outside city if feasible.
- xv. Strategy for sustainable operation & maintenance of storm water systems
- xvi. A holistic approach to local area planning including aspects of sustainability, consistency, and responsiveness to community values
- xvii. In integrated water use planning, as outlined in Chapter 10, the plan preparation should consider the integration of storm water, recycle and reuse of treated wastewater and freshwater resources to address the urban flooding issue and water security issue of the city simultaneously

Note:

- a. It is emphasized that the earlier method of combined sewerage system collecting storm water and sewage in the same pipe network is resulting in several adverse effects in the process of treatment, operation, maintenance and also on the environment. Therefore, it is recommended that for collection and treatment, sewage should be separated from the storm water drainage system as it is currently in practice all over the world.
- b. Storm water open channels if not covered are prone to the dumping of garbage and other waste, encroachment, etc. that may cause choking and disruption of flow causing street flooding and inconvenience to the residents of the area. It would be advisable in such circumstances to construct underground storm water conduits that shall remain immune to such practices and shall provide extra space on the surface.

2.3 Data Collection, Survey and Investigation

Before the start of field survey, sufficient desk work should be carried out using the existing details and that should be corroborated by field visits and discussions with local community and municipal officials. This iterative process should be followed to prepare a comprehensive workable plan. The data/information to be collected and the elements to be surveyed for preparation of the project plan are given below:

2.3.1 Data Collection

The data collection shall comprise of the following but not limited to:

I. Physical Characteristics

- a) Topographical details including the slope of catchment / contributing area and outfall point
- b) Identification of existing and expected future land uses
- c) Identify a list of open spaces
- d) Details of Bridges, culverts, railway crossings, etc.
- e) Areas of the urban forest, wetlands, marshy lands, flood plains, water bodies, etc.
- f) Data on inflows from contiguous upper regions
- g) Soil characteristics including its permeability
- h) Groundwater table and its seasonal variations
- i) Location and capacity of Existing water retention structures
- j) Details of Wastewater treatment plants along with their capacities
- k) Treated wastewater available for recycle and reuse out of decentralized wastewater plants in city/housing complexes
- l) Potential of use of storm water in the project area or adjoining area
- m) Identification of storm drainage related problems within urban areas that may warrant further detailed investigations and planning such as:

- Littering, garbage, domestic wastes, plastic waste, etc.
- Solid waste / C & D waste points nearer to the drainage system
- Nearby dump site status
- Natural pollution, such as leaves, etc.
- Chemical pollution, such as detergents, oil or fertilizers



Figure 2.1: Identify dumping of garbage points

II. Rainfall Characteristics

- a) Rainfall data for the last 30 years or more depending upon the availability from digitized / Automatic Rain gauge station needs to be obtained / collected from IMD in the specified format
- b) Rainfall data collection comprising of annual average daily and monthly rainfall and no of rainy days
- c) Data on historical flood events

III. Waterway Characteristics

- a) The capacity of water receiving the body and its HFL and other relevant details
- b) Physical condition and characteristics of the existing (size, slope, and material) storm water conveyance system
- c) Existing natural, as well as, engineered drainage channels
- d) Details of existing water bodies
- e) Location of existing and prospective rainwater harvesting structures;
- f) Water quality & quantity in existing storm water conveyance systems / natural drains and in receiving water bodies under wet and dry conditions
- g) Tidal influence on receiving water bodies for the catchment

IV. Collection of topographical survey details/maps

Following documents/maps are needed to be collected for proper planning:

- a) Survey of India topographical maps (1:50,000) of the catchment/planning area for comprehension of topography, watercourses and other physical features like major roads, railway lines, location and levels on benchmarks, etc.
- b) Details of benchmarks established by Survey of India in the planning area or its neighborhood
- c) Existing aerial survey of the planning area
- d) Digital data/satellite data
- e) Local planning area maps and scheme maps of various scales prepared by various agencies such as Department of Town and Country Planning, Water & Sewerage Boards, Municipal Corporations, etc. for comprehension of watercourses, irrigation channels, storm water drains, tanks, temple, ponds, etc.

- f) Reconnaissance survey for verification and updation of the complete inventory of drainage system of the planning area consisting of watercourses, irrigation channels, storm water drains, tanks, temple ponds, etc.
- g) Reports on existing drainage system and its study/evaluation, if any.
- h) Location of underground electric cables, telephone lines, water supply, and sewer lines, etc.
- i) Watershed maps including topographic features, watershed boundaries, existing drainage patterns, and ground cover

2.3.2 Survey and Investigation

After analyzing the collected data including the existing survey maps and existing drainage details, broad alignment for drainage network should be firmed up and the survey should be commenced to collect the requisite data/field details for the preparation of alignment of drains/maps with suitable ground levels.

For carrying out the survey, the latest survey instruments like Total Station Survey / Mobile LiDAR/ Drone / aerial survey techniques, etc. should be used. Based on the survey, the coordinates and levels of various important locations/benchmarks should be collected. Further, field survey for the project should include overall infrastructure mapping, strip survey and site survey. During the topographical survey, traversing should be done along the centre line of the corridor. Longitudinal cross-sections should be taken at intervals as required for clarity. Also, the final data should be converted in Environment System Research Institute (ESRI) (Shapefile) format with its defining projection and survey collected attributes in the requisite database format.

The layout plan should be prepared and integrated on the GIS base with a selected computer model. Layers and attributes to be shown on the map should be flexible to control and give appropriate information for different requirements. The city should prepare GIS maps of storm water drainage system and upload in public domain (Respective ULB website). This would help in regular monitoring of the drainage system to ensure that there is no encroachment. This will also facilitate ease in operation & maintenance.

Based on the above survey, following plans should be prepared:

- a) Topographical maps (1:1000) bringing out existing storm water drainage system, the crossing of main watercourses eg. rivers, irrigation channels, and drains, tanks, ponds, roads, railway lines, built-up areas, open fields, and playgrounds, flood-prone areas, etc.
- b) Contour maps

- c) Demarcation of the urban catchment in sectors, zones and subzones to plan layout of Primary, Secondary & Tertiary drains
- d) Alignment of watercourses showing locations of temporary/ permanent structures within 15 m on either side of the bank location of electric cables, telephone lines, water supply, and sewer lines in the vicinity of the drains
- e) Storm water drains with a longitudinal section at 30-50 m interval and cross-section at every 1 m interval within the drain and 2 - 5 m outside the drain
- f) Mapping of storm water drainage layout on GIS platform
- g) Water harvesting structures, Water detention tanks, Pumping points, water usage points, parks, disposal point should also be shown on the map
- h) Details in and around the drain for recharge should also be identified particularly at the places along the stretch of the drain where soil strata/log is changing indicating Type of soil, Permeability, Ground Water Table, Rock strata
- i) Identification of Vulnerable silting / landslide points, Low lying points Coastal area problem, Hilly area features / vulnerable stretches
- j) The above details collected can be used for planning of drainage system including its integration with existing drains and rehabilitation of other existing drains

2.4 Planning of Storm Water Drainage Systems

2.4.1 Demarcation of Catchment and Planning Areas

While planning storm water drainage system for the city, the catchment area should be demarcated based on natural watershed boundaries (Ridges / Valleys/ Waterways) to take into account storm water runoff. Wherever, Storm water runoff enters from the adjacent catchment, in such cases, the city should take necessary efforts to minimize the runoff entering into the city by proposing various measures such as diverting the flow to the exiting reservoirs, lakes, water bodies and by construction of check dams, reservoirs, etc. Demarcation of planning area into sectors, zones, and subzones in order to plan layout of Primary, Secondary & Tertiary drains based on topography, road alignment, railway lines, culverts, bridges, etc. need to be carried out consistent with contour plans of the planning area.

If topographical and contour maps are available then these shall be meticulously used to identify the prevailing Storm Drainage corridors otherwise fresh topographical survey, contour maps of the existing catchment including proposed extended Project areas (if any) need to be configured by a detailed survey. Thus, the comprehensive mapping shall facilitate the entire planning process of design and the imperative 'Detail Engineering' components of the catchment.

Existing drainage facilities also need to be examined with respect to shape, size, material, invert information, outfall location(s), age, condition, etc., consistent with the volume of storm water flow and suitably integrated with new drains including augmentation/rehabilitation of existing drains to convey the designed runoff efficiently.

2.4.2 Hydraulic Design of Storm Water Drainage Systems

Using the data collected above and a topographical survey carried out, the route of drains should be marked on the map along with ground levels and showing existing infrastructure, including various other salient features as mentioned above. Also, the rainfall data should be collected and analyzed as mentioned in Chapter 3, and runoff estimation to be carried out for different zones/subzones for corresponding stretches of drain alignment as given in Chapter 4. The runoff from the adjacent catchment area as said above should also be taken into account while designing the storm water drains. Using this runoff data, the storm water drains should be designed following the aspects of design as mentioned in Chapters 5, 6 & 7. Reduction in storm runoff by constructing retention/detention ponds / Rooftop rainwater harvesting etc. as given in Chapter 9 and Chapter 10 should also be accounted for while designing the drainage system.

However, it may be mentioned that internal drainage of urban catchments may not be designed for peak flow for rare storm events such as 1 in 25 or 50 years or so, but it is necessary to provide sufficient protection against excessively frequent flooding of the drainage area. The Design Return period is presented in Chapter 4.

There shall be considerable flooding when the precipitation exceeds the 'Design Return Storm'. However, such flooding may have to be accepted in spite of once in a while inconvenience considering its occasional utilization in few instances in a year and the nature of cost-intensive projects and its feasibility on the ground due to various other utilities available along the road. However, in such situations, the preparatory measures to deal with such scenarios as specified by 'National Disaster Management Guidelines, published in September 2010' (Chapter 3 and related sections). In case of frequent flooding, special structures like underground conduits/tunnels may be proposed as specified in section 10.2.4 of Chapter 10.

2.4.2.1 Inlet locations

The storm water inlets (Catch pits / Catch-Basins) are mainly provided to accommodate the storm water from paved surfaces (Kerb & channels for large metropolis), parks, open space areas and transfer it to subsurface drains for conveyance to the ultimate 'receiving body'. The inlets are connected to open drains by means of interconnection pipes. The inlets need to be hydraulically designed and suitably spaced. The detailed norms for design are in Chapter 5. Inlets should be adequately designed and placed to efficiently drain storm water runoff into main drainage system.

2.4.2.2 Manholes (MHs) and its locations

Manholes (MHs) in the sub-surface drainage system are provided at the following locations:

- a. Major change in flow quantum due to the addition of flows (junctions)
- b. Bends because of change in the direction of alignment
- c. Large drops in inverts because of topographical configuration
- d. Routine MHs at regular intervals even when there is no hydraulic or geographic transition. These MHs is necessary for regular maintenance purpose

The detailed norms for design are in Chapter 11.

2.4.2.3 Pumping of storm runoff

Storm runoff follows the gradient of the terrain in the drainage catchment. In many low lying stretches with flatter slope as well as near coastal areas or wherever collection tank/storage reservoirs/ detention tanks are proposed, the pumping arrangement becomes necessary for efficient functioning of storm water drainage systems and designing of storm water runoff to prevent inundation in the city. While designing pumping system, the following basic aspects should be considered:

In the case of permanent pumping stations the following need to be considered

- a. Identification of pumping points
- b. Details of space availability
- c. Distance/route of the rising main alignment
- d. Estimation of design runoff at the pumping station
- e. The capacity of the wet well, i.e. the detention time in minutes pertaining to the peak of the Routed Hydrograph at the Drainage Pumping Node
- f. Additional storage capacity if required
- g. Number of pumps including standby and operating point (Q vs. H) of pumps, determined from synchronization of pump characteristics (single or in parallel) & system head curve and authenticated through NPSH, as well as, discharge vs power input curves and other typical elements related to the pumping system
- h. Electric motors or fuel engine driven pumps
- i. Operation and maintenance requirement

- j. Generator sets of appropriate capacity as standby for emergency operation during failure of electricity

The detailed norms relating to pumping are mentioned in Chapter 8.

2.4.2.4 Outfall Structures

Location of outfall point should be selected considering the level of the surface water of receiving water bodies such as low water level, high water level, and normal water level. Care should be taken that the outfall level should be adequately high above the High Flood Level. Wherever it is not feasible due to the level of terrain adequate protection mechanism should be provided to check backflow of water in the outfall drain. Cascading and apron structure if necessary may be incorporated in the Outfall Structure System. The accessible location of outfall structures should be clearly shown on the plan. The detailed norms for design are mentioned in Chapter 6.

In cases of probable flooding of the catchment due to flooding of natural streams/ rivers, flood protection measures should be employed.

2.5 Other Considerations

2.5.1 Permissions and Clearances

The necessary permissions and clearances may be obtained in advance along the drainage alignment for the smooth implementation of the project. Further, the permission for removal /relocation / or diversion of existing services should be taken up with concerned department at an adequate earlier stage within the ambit of project planning and implementation procedure because the process is normally lengthy. Town planners and engineers, therefore, should start the process to obtain necessary government sanction at a very early stage to avoid delay in project implementation.

2.5.2 Environmental Consideration

It pertains to the aspects to be considered in relation to the environment such as aesthetics, landscape, groundwater recharge, etc.

i. Environmental Assessment

The environmental impact assessment should be carried out in accordance with the procedures prescribed by Government of India under Environment (Protection) Rule 2006 and 2009 wherever applicable.

ii. Aesthetics/Landscape

Urban Drainage infrastructure shall be so planned and designed that the same should holistically blend with the surrounding environment. Aesthetic aspects should be stressed in structural designing and landscaping to create a symmetrical and perspective vision with the spatial environmental backdrop.

iii. Surface Water

Considerable quantities of trash and other debris are washed through storm water drainage system into receiving water bodies of water resulting as a primary impact in the creation of an aesthetic eyesore in waterways causing reduction in recreational value, whereas, in smaller streams debris may generate blockage of the channel which may result in localized flooding and erosion. This shall be meticulously studied, and remedial measures need to be proposed.

iv. Ground Water

Increased urbanisation has resulted in the increase in percentage imperviousness and in turn precluding the natural infiltration process of storm runoff. Such phenomenon reduces groundwater recharge rate and consequently lowering the groundwater table. This aspect shall be taken into consideration while designing recharge structures and suitable treatment measures to be proposed if such recharge is contemplated to be carried out.

v. Coastal Water

Sediments, silts, debris, etc. discharged through storm drainage system into coastal waters, and recreational sea beaches may cause physical damage, including degradation of water quality and smothering benthos. Nutrients such as nitrogen and phosphorus in excess in storm water may cause eutrophication resulting in excessive algal growth. This should be adequately taken care of.

2.6 Financing

Project implementation involves Capital as well as O & M cost.

Capital cost includes all initial costs such as civil construction, cost of drains appurtenances, pumping machineries installation and erection costs, opportunity cost (land cost in case of government land), engineering design and supervision charges, interest charges on loan if taken during the construction period.

Financial viability of any project is as important as its technical viability and it can also be said that operating cost is more important than the capital cost to ensure the

sustainability of the project. The benefits from storm drainage project may not be quantifiable in cash inflow terms, but its social, health, and other benefits can be assessed more than revenue accrual.

For efficient functioning of storm water drainage system, proper operation & maintenance is essential, which is possible only when O & M funds are available to take up maintenance activities. The fund may be earmarked from drainage activities from municipal budget and may be collected in the form of storm water drainage cess based on area of premises and level of construction done.

Annual Operating costs after the project is commissioned shall include the summation of the direct operating cost and fixed costs like amortization and interest on capital borrowings, direct operation and maintenance costs on the following:

- a. Staff
- b. Chemicals (if any)
- c. Fuel and electricity
- d. Transport
- e. Maintenance and repair
- f. Insurance
- g. Overheads etc.

On the other hand, the annual benefits arrived from such social engineering projects are multifarious in terms of:

- i. Direct revenue earning from the beneficiaries through development and betterment taxes with multilevel taxation putting the minimum burden to the economically weaker section of the community
- ii. The indirect benefits in terms of improvement of general public health which can be termed as socio-environmental benefits

If one can assess and quantify the summation of all such benefits, the Benefit/ Cost Ratio (B/C) for such social engineering projects are always expected to be more than unity.

2.7 Operation & Maintenance

For any system to operate in a proper and efficient manner, the key is its appropriate and planned regular and preventive operation and maintenance. These aspects of O & M have been addressed in Part B of the manual.

2.8 Citizen Awareness

Citizen awareness is the growing recognized mechanism to dissuade people from the habit of indiscriminate littering and dumping of debris and solid waste either on open ground or nearby rivers/ streams/lakes/drains. This is dealt in detail in Part C of this manual.

2.9 Institutional Arrangement and Capacity Building

Creation of storm water drain infrastructure is one aspect, but its periodic maintenance is the key to provide the desired level of services on a sustainable basis. An efficient organization is very important for planning, design, and sustainable operation and maintenance of SWD infrastructure. Therefore, measures must be taken for institutional strengthening and internal capacity building so that the efforts made can be sustained over a period of time and the system put in place can be well managed. Institutional strengthening can be done by adequately decentralizing the administration, delegating adequate powers at the decentralized level, inducting professionals into the administration, and providing adequate training to the existing staff. These are dealt with in detail in Part C of this Manual.

2.10 Service Level Benchmark

While planning a project, efforts should be made to perform as per Service Level Benchmark notified by Ministry of Housing and Urban Affairs, (MoHUA) Govt. of India, as shown in Table 2.1 below:

Table 2.1 Performance Indicator

Indicator	Value
Coverage of storm water drainage network	100 %
Aggregate number of incidents of waterlogging reported in a year	0 per year

2.11 Incorporation of storm water drainage indices in the hydraulic design of storm water drains and its O & M

To assess and monitor the progress of implementing sustainable storm water management, the following 20 parameters/indicators need to be integrated at its various stages of design and operation & maintenance. These parameters are generally in the form of indices for systematic and scientific assessment of the situation, progress, and deficit which need to be considered at all stages of development namely, Planning, Design, Implementation, and Operation &

Maintenance subject to its appropriateness and significance to the specific stage. These 20 parameters are as given in the table 2.2.

Table 2. 2 Parameters / Indicators

1	Master Plan Index	2	Natural Drainage System Index	3	Drainage Coverage (Constructed) Index
4	Permeability Index	5	Water bodies Rejuvenation Index	6	Waterbody Vulnerability Index
7	Waterlogging Index	8	Area Vulnerability Index	9	People Vulnerability Index
10	Flood Moderation Index	11	Drainage Cleaning Index	12	Complaint Redressal index
13	Climate Change Stress Index	14	Storm water discharge quality Index	15	Sewage Mixing Index
16	Preparedness Index/ Early Warning Index	17	Rainfall Intensity Index	18	System Robustness Index
19	Tidal Index	20	Rainwater Harvesting/Artificial Groundwater Recharge Index		

Further details may be referred to the Ministry of Housing & Urban Affairs website under the National Mission on Sustainable Habitat (<http://mohua.gov.in/cms/National-Mission-on-Sustainable-Habitat.php>)

2.12 City Drainage Master Plan

Drainage Master Plan is usually prepared for big cities as their coverage at one time may not be financially feasible due to huge cost investment. The master plan provides a broader framework of the system such as broad layout plan and other system components, outfall locations, rainfall characteristics enunciating the design criteria, outline and brief description of system components. The drainage master plan should be prepared in consonance with the City Master Plan, keeping in view the land use plan of the city. Broad cost estimates are also framed for clearance and approval of master plan by competent authorities. Its main objective is to direct and control DPR formulation consistent and conducive with the master plan framework and provision so that future sectorial development of storm drainage infrastructure should function as whole system of master plan rather than separate part.

2.13 Preparation of Reports

Identification and Pre-Feasibility Reports are prepared before framing of detailed project report which is oriented to get initial approvals to proceed on preparation of DPRs. The approach for preparation of Identification and Pre-Feasibility report are adequately explained in Chapter 3 of Manual on Sewerage and Sewage Treatment, 2013 of Part A: Engineering, and can be referred.

2.13.1 Preparation of DPR

DPR preparation is an important stage to capture all existing relevant details and also the proposal along with cost estimate, layout maps and other relevant documents as explained in following paras. DPR should contain the following:

- i. Executive Summary
- ii. Introduction
- iii. Project Planning Area
- iv. Existing situation
- v. Proposed project planning and detailed design
- vi. Environmental Impact Assessment
- vii. Cost estimation
- viii. Key Plan/Map/Longitudinal Section
- ix. Annexures

2.13.1.1 Executive Summary

An Executive summary should be briefly describing the needs, objectives, project proposals, cost, the life of project, beneficiaries, implementation schedule, results of Social, Environmental Studies/Analysis, funding sources, institutional arrangement, annual O & M, economical & financial analysis, etc. It should be provided at the beginning of the project report which is just like project at a glance for the project authorities to understand the project and its benefits, its financial and technical viability so that the authorities may take decisions for funding and implementing the project.

2.13.1.2 Introduction

The section should provide a brief history of project, existing situation, its needs, project area and location, topography, contour plans, rainfall pattern, which are essentially required for storm drainage plans, rivers and streams either fringing or crossing the project area, findings

of earlier studies, whether data/ information collected is adequate and sufficient to formulate the comprehensive project. Whether earlier studies have suggested an appropriate design storm that could cope with frequent flooding and congestion. Whether history of specific storm tracks that led to heavy flooding have been recorded. The summary of aforesaid elements shall be provided with map showing the topography and landscape of the project area.

2.13.1.3 Project Planning Area

The factors that influence the determination of the project area include natural topography, layout of buildings, political boundaries, economic factors, CMP, etc. For larger drainage areas, though it is desirable that the drain capacities are designed for the total project area, sometimes the political boundaries and legal restrictions prevent construction of drains beyond the limits of the local authority. However, when designing drains for larger areas, there is usually an economic advantage in providing adequate capacity initially for a certain period of time and constructing additional drains, when the pattern of growth becomes established. The need to finance projects within the available resources necessitates the design to be restricted to political boundaries. The project area under consideration should be marked on a key plan so that the area can be measured from the map.

2.13.1.4 Existing situation

Existing storm drainage facilities if available in the planning area, essential relevant data of the system shall be gathered from town/city authorities and examined its viability to function and accommodate the current design storm runoff. The condition and age of the drainage infrastructure shall be determined to assess its further life. This evaluation and assessment of the existing system if found satisfactory and fit for integration with proposed system then the existing system should be dovetailed with the proposed system.

2.13.1.5 Proposed Project and detailed design

This section shall deal with the following aspects:

- i. Topographical survey of the project area and types & area of different surfaces in the project area.
- ii. Contour plans, Location of outfall structures.
- iii. GIS map for storm water drainage system
- iv. Rainfall data (intensity duration) for a long period not less than 25 years, preferably more years.
- v. Frequency analysis for design storms as recommended for the project area.

- vi. The proposed network of surface drains or subsurface drains drawn on the map showing location of manholes and street inlets, catchment/ basin, etc. The network of surface drains is proposed considering Service level benchmarking.
- vii. Design of proposed drain either manually or by aid of computer software.
- viii. A brief description of each component of project should be given with relevant maps and drawings
- ix. Function, location, design criteria, and capacity of each component should be provided.
- x. Description of the technical integration of the existing drainage system, if any, with the proposed project. In case the existing system is unworkable, suggest means either to improve or rehabilitate, if feasible.
- xi. Technical specification and performance specifications should be clearly defined and recorded.
- xii. Phasing out year-wise work schedule to achieve required service levels with respect to coverage and nil incidence of flooding and correlate its improvement.

2.13.1.6 Environmental Impact Assessment

Environmental Impact Assessment (EIA) Study and Social Study should be done for the construction and post-construction period. Adverse effect shall be examined and suggestion for remedial measures will be provided if any.

2.13.1.7 Cost Estimation

Detailed cost estimates based on SOR effective in the project area or analysed rates of items not covered under SOR at current market rate should be prepared. Total capital investment thus estimated should be broken into annual cash flow required considering the time of completion as stipulated under the project objective. Method of financing of project may also be dealt by identifying all sources of funding to implement the project, indicating year-wise requirement from these sources and to meet expenditure as planned for completing the project as per schedule. Estimated cost of operation and maintenance of the facility for a period of 5 to 10 years from the probable year of commissioning should be worked out including annual operating cost considering salary of staff and other allied service benefits, cost of chemicals, energy, transport, routine maintenance of civil works, maintenance of electrical/mechanical equipment including normal cost or replacement of spares and supervision charges

2.13.1.8 Implementation Schedule

Detailed and realistic implementation schedule for all project components taking into consideration, stage of preparation of detailed design and drawings, additional field investigations required, if any, time required for preparing tender documents, notice period, processing of tenders, award of work/supply contract, actual construction period, time required for procurement of materials and equipment, testing, trials of individual components and systems and commissioning of facilities etc. Implementation schedule for support activities such as staff training, improving billing and accounting, consumer involvement, etc. should also be prepared as well as timing of undertaking these components and agencies involved.

2.13.1.9 Conclusions and Recommendations

This section should discuss the justification of the project in terms of objectives to be achieved, cost-effectiveness, affordability, tariffs, and willingness to pay user charges from beneficiaries to accept the services. To establish financial viability cost-benefit analysis and internal rate of return for entire project cycle may be worked out and provided in the report. Phasing of works, in view of construction of all types of drains - primary, secondary and tertiary in a catchment area should be done during the project execution period, considering priority areas in the city. It should also be provided in the project report.

2.13.1.10 Checklist for DPR preparation

A checklist has been prepared and placed in Appendix 2.1, which can be referred to by the users of this manual towards preparation/scrutiny of DPRs of storm water drainage.

CHAPTER 3: RAINFALL ANALYSIS

3.1 General

In storm water drainage system design, estimation of runoff from the tributary catchment reaching various inlets of the drain is important. This can be estimated if Intensity Duration Frequency (IDF) curves are available. The IDF curve is drawn based on rainfall data analysis of the project area obtained from the daily rainfall charts of Self-recording Rain Gauge (SRRG) stations of Indian Meteorological Department (IMD).

In this Chapter, the rainfall data obtained from SRRG station of IMD has been analysed, and the procedure for construction of IDF curve using Empirical method is explained. Once IDF curve for required return period are constructed, the same can be used for estimation of runoff using rational method. Probabilistic methods for constructing IDF curves have also been explained in brief.

3.2 Rainfall

Rainfall is a form of precipitation. The term precipitation is a generic term used to denote all types of precipitation that reaches surface of the earth from the atmosphere such as rainfall, snowfall, frost, hail, sleet, drizzle, glaze, and dew. Rainfall (water drops of size 0.5 mm – 6 mm) is the major form of precipitation that causes stream flow as well as flood flow in rivers. Variation in magnitude and duration of rainfall in different parts of the country leads to potential of flooding of urban areas where the drainage systems are inadequate. Based on the magnitude, the rainfall is classified as Very light Rain (0.1- 2.4 mm/day), Light Rain (2.5 – 15.5 mm/day), Moderate Rain (15.6 – 64.4 mm/day), Heavy Rain (64.5 – 115.5 mm/day), Very Heavy Rain (115.6 – 204.4 mm/day) and Extremely Heavy Rain (>204.5 mm/day).

3.2.1 Measurement of Rainfall

Rainfall is measured by two types of gauges:

- i. Self-recording type
- ii. Non-recording type

Self-recording type rain gauges automatically record daily a continuous plot of rainfall depth against time down to 15 minutes interval or even less, whereas, non-recording rain gauges can only record cumulative rainfall for a day that is measured daily at site. The data collected using non-recording gauges are of limited use for design purpose. Hence, non-recording gauges are being gradually replaced in Indian subcontinent.

Therefore, the mechanism of types of self – recording gauges that are in current use has been discussed as follows:

3.2.1.1 Tipping Bucket Type Rain Gauge

Tipping bucket type rain gauge is a 30 cm sized circular rain gauge adopted for use. It has 30 cm diameter sharp-edged receiver, and at the end of the receiver, a funnel is provided.

Pair of buckets is pivoted under this funnel in such a manner that when one bucket receives 0.25 mm of precipitation (rainfall), it tips discharging its rainfall into the container, bringing the other bucket under the funnel as shown in Fig 3.1.

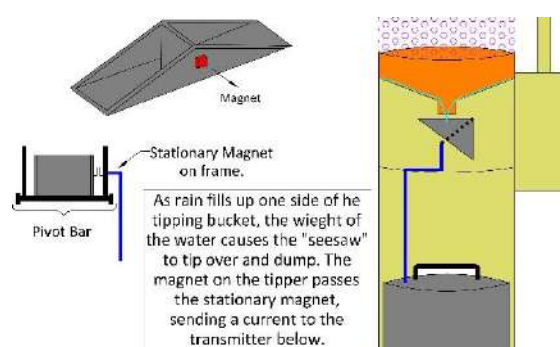

Figure 3. 1 Tipping bucket type rain gauge

Tipping of bucket completes an electric circuit causing the movement of the pen to mark on a clock driven receiving drum which carries a recorded sheet. These electric pulses generated are recorded at the control room far away from the rain gauge station. This instrument is further suited for digitalizing the output signal.

3.2.1.2 Weighing Bucket Type Rain Gauge

Weighing bucket type rain gauge is the most common self-recording rain gauge. It consists of a receiver bucket supported by a spring or lever balance or some other weighing mechanism. The movement of bucket due to its increased weight is transmitted to a pen which traces record or some marking on a clock-driven chart as shown in Fig 3.2.

Weighing bucket type rain gauge instrument gives a plot of the accumulated (increased) rainfall values against the elapsed time and the curve so formed is called the mass curve.

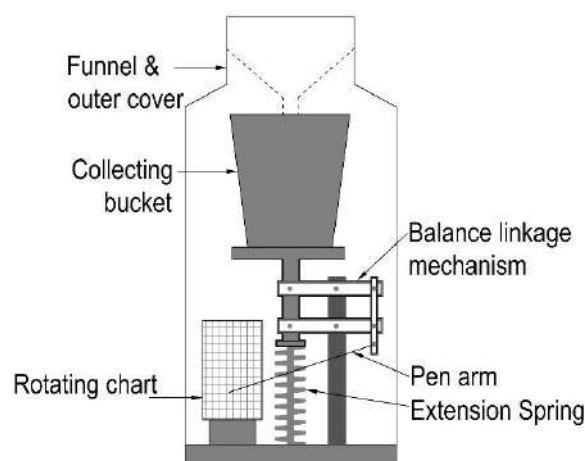

Figure 3. 2 Weighing Bucket Type Rain Gauge

3.2.1.3 Floating or Natural Syphon Type Rain Gauge

The working of this type of rain gauge is similar to weighing bucket rain gauge. A funnel receives the water which is collected in a rectangular container. A float is provided at the bottom of container, and this float rises as the water level rises in the container as shown in Figure 3.3. Its movement is recorded by a pen moving on a recording drum actuated by a clockwork.

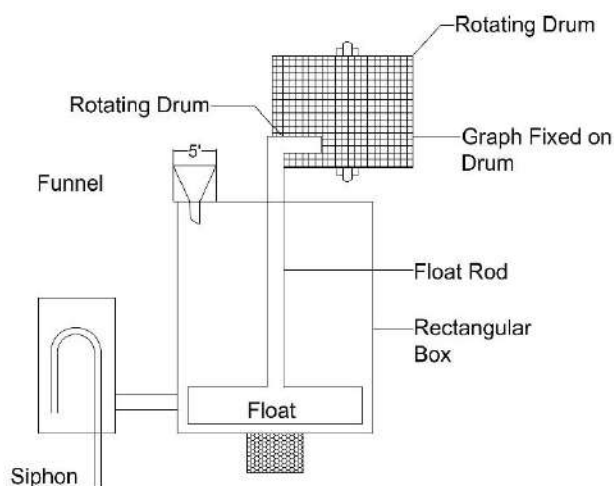

Figure 3. 3: Natural Syphon or Float Type Rain Gauge

When the water rises, this float reaches to the top, and then syphon comes into operation and releases the water outwards through the connecting pipe, thus all water in box is drained out. This rain gauge is adopted as the standard recording rain gauge in India.

Note: In most of the cases, IMD has installed Self – Recoding Rain Gauge (SRRG) in various cities and towns and the necessary desired/required data may be collected by the Project Implementing Agency. In case, SRRGs are installed by the States/Cities or any Agencies on their own, the necessary desired/required data may be facilitated to the Project Implementing Agencies, as per State Rules.

3.3 Rain Gauge Density

The rain gauge density in a catchment is defined as the ratio of the total area of the catchment to the total number of rain gauge stations in the catchment. The term gives the average area served by each gauge. World Meteorological Organization, WMO (2008) has given guidelines regarding the minimum network density for urban areas as one rain gauge per 10 - 20 Sq.km. As per disaster management point of view, NDMA (National Disaster Management Authority) has recommended ARGs (Automatic Rain Gauge Stations) should be installed in all urban cities (Class I, II and III) with a density of 1 per 4 sq km.

Accordingly, following rain gauge density is recommended in urban areas:

- i. Population more than 10 Lakh : 1 rain gauge per 5 - 10 Sq.km.
- ii. Population between 1 Lakh to 10 Lakh : 1 rain gauge per 10 - 20 Sq.km.
- iii. Population less than 1 Lakh : 1 rain gauge per town.

3.4 Rainfall Analysis

Rainfall analysis is carried out to identify and sort out various magnitudes (intensities) of rainfall events and their corresponding durations occurring at a station from a continuous series of historical rainfall records taken for a fairly long period viz. last 25 - 30 years or more. IDF curves are not static as they are influenced by change in pattern of rainfall and therefore IDF curve should be prepared at an interval of 5 – 10 years for accurate results. The rainfall analysis helps to establish intensity-duration-frequency relationship for various frequencies which are used in estimation of runoff for design of storm water drains. The frequency or return period of a storm event may be defined as the average recurrence interval between events equal to or exceeding a specified magnitude. Thus, if it is stated that the return period of rainfall of 20 cm in 24 hours is 10 years at a certain station A, it implies that on an average rainfall magnitudes equal to or greater than 20 cm in 24 hours occur once in 10 years.

3.4.1 Steps for Analysis of Rainfall

To illustrate the procedure of rainfall analysis, a continuous series of rainfall intensity and corresponding durations of historical storms of 29 years of Bhubaneshwar town is obtained from SRRG charts of each day from IMD rain gauge station at Bhubaneshwar. The data has been analysed for various return periods. Procedure is explained by the following steps:

STEP 1: The SRRG tabulated data may be obtained from IMD. In case, the tabulated data is not readily available then the SRRG Charts may be analysed to tabulate the data as explained with the help of a one day chart in the following Figure 3.4.

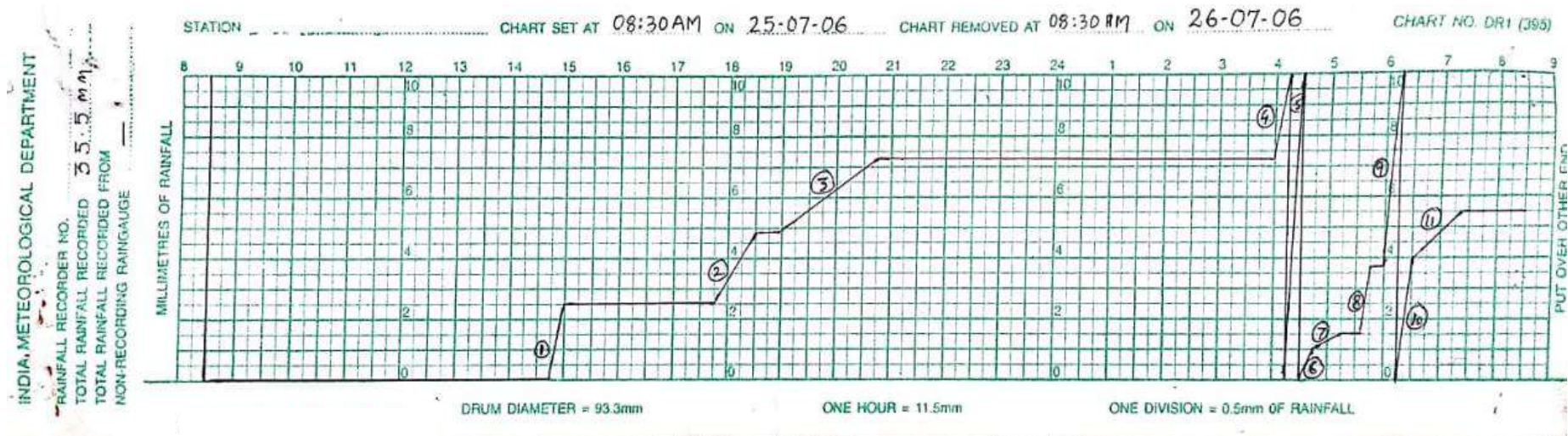

Figure 3.4: SRRG Chart for 24 hrs

From the sample SRRG chart given in Figure 3.4, tabulate rainfall of individual storm, its duration and find out intensity as given in the Table 3.1:

Table 3.1: Storm of intensities corresponding to duration

Year	Month	Date	Sr. No of Storms in Particular Day	No of Horizontal Divisions	Time in (minutes)	Time (Hours)	No of Vertical, Divisions	Rainfall in mm	Rainfall Intensity 'I' mm/hr
(a)	(b)	(c)	(d)	(e)	(f)	(g)= (f)/60	(h)	(i)=(h)x0.5	(j)= (i)/(g)
2006	July	25	1	1	15	0.25	5	2.50	10
			2	3	45	0.75	4.75	2.375	3.17
			3	7	105	1.75	4.75	2.375	1.36
			4	1	15	0.25	5.5	2.75	11.0
			5	1	15	0.25	20	10.0	40.0
			6	1	15	0.25	2	1.0	4.0
			7	2	30	0.5	1	0.5	1.0
			8	0.5	7.5	0.125	4.5	2.25	18.0
			9	1	15	0.25	12.5	6.25	25.0
			10	1	15	0.25	8.25	4.125	16.5
			11	3.5	52.5	0.875	2.75	1.375	1.57

Sort out the storms in various group of intensities corresponding to the duration of occurrence of storms. The number of storms are calculated and grouped in intensities of 5 – 10 mm/hr, 10-15 m/hr and so on corresponding to each group of duration of occurrence as shown in the Table 3.2. Rainfall intensity below 5 mm/hr has not been taken for analysis.

Table 3. 2: Sorted storms against intensity and duration

	Duration in Mins	Intensity (mm/Hr.)															
		5-10	10-15	15-20	20-25	25-30	30-35	35-40	40-45	45-50	50-55	55-60	60-75	75-90	90-120	120-150	>50
Upto 5	5																
5 to 10	10			1													
10 to 15	15	1	1	1	1			1									
15 to 20	20																
20 to 25	25																
25 to 30	30																
30 to 40	40																
40 to 50	50																
50 to 60	60																
60 to 75	75																
75 to 90	90																
90 to 105	105																
105 to 120	120																

STEP 2: Similarly, sort no of occurrences of rainfall intensities against corresponding duration for entire sample size of rainfall data obtained using MS Excel as shown in the Table 3.3.

Table 3.3: Sorted storms against intensity and duration

Duration in min	Intensity (mm/Hr.)															
	5-10	10-15	15-20	20-25	25-30	30-35	35-40	40-45	45-50	50-55	55-60	60-75	75-90	90-120	120-150	>150
Upto 5	35	13	22	4	11	1	2	3	5	2	4	3	3	1	1	1
5 to 10	149	40	57	23	14	4	7	6	7	2	7	4	4	1	1	
10 to 15	151	69	45	23	21	17	18	4	5	2	1	5	3	1	2	
15 to 20	4	2	6	0	1	0	1	0	0	0	0	1	0			
20 to 25	53	30	16	8	8	3	9	2	3	0	0	2	0			
25 to 30	89	53	37	32	22	5	11	5	5	3	0	0	0			
30 to 40	41	13	10	9	1	1	5	2	0	0	1	0	0			
40 to 50	81	41	23	9	11	6	9	2	2	3	0	0	1			
50 to 60	55	37	29	20	5	5	9	1	3	1	1	1	1			
60 to 75	32	21	16	10	14	5	3	2	1		1	1				
75 to 90	46	19	11	11	3	3	1	2			1					
90 to 105	30	13	4	4	5	2	0		2							
105 to 120	19	15	8	5	0	3	1									

STEP 3: Add number of storms of all exceeding intensities to the preceding /lesser intensities storms. For instance, in Table 3.3, number of storms corresponding to 5 min duration and various intensity groups i.e. 5 - 10 are added as $35 + 13 + 22 + 4 + 11 + 1 + 2 + 3 + 5 + 2 + 4 + 3 + 3 + 1 + 1 + 1 = 111$. Similarly, number of storms are added horizontally for each duration of storms and tabulated in Table 3.4.

Table 3. 4: Number of storms after horizontal addition

Duration in minutes	No. of Storms of Intensity(mm/Hr) or more															
	≥5	≥10	≥15	≥20	≥25	≥30	≥35	≥40	≥45	≥50	≥55	≥60	≥75	≥90	≥120	≥150
Up to 5	111	76	63	41	37	26	25	23	20	15	13	9	6	3	2	1
5 to 10	326	177	137	80	57	43	39	32	26	19	17	10	6	2	1	0
10 to 15	367	216	147	102	79	58	41	23	19	14	12	11	6	3	2	0
15 to 20	12	8	6	3	3	2	2	1	1	1	1	1	0	0	0	0
20 to 25	134	81	51	35	27	19	16	7	5	2	2	2	0	0	0	0
25 to 30	262	173	120	83	51	29	24	13	8	3	0	0	0	0	0	0
30 to 40	83	42	29	19	10	9	8	3	1	1	1	0	0	0	0	0
40 to 50	188	107	66	43	34	23	17	8	6	4	1	1	1	0	0	0
50 to 60	168	113	76	47	27	22	17	8	7	4	3	2	1	0	0	0
60 to 75	106	74	53	37	27	13	8	5	3	2	2	1	0	0	0	0
75 to 90	97	51	32	21	10	7	4	3	1	1	1	0	0	0	0	0
90 to 105	60	30	17	13	9	4	2	2	2	0	0	0	0	0	0	0
105 to 120	51	32	17	9	4	4	1	0	0	0	0	0	0	0	0	0

STEP 4: Add number of storms of all exceeding durations to the preceding / lesser duration storms. For instance in Table 3.4, number of storms corresponding to ≥ 5 mm/hr intensity are added as $111+ 326+ 367+ 12+ 134+ 262+ 83+ 188+ 168+ 106+ 97+ 60+ 51=1965$. Similarly, number of storms are added vertically for each Intensity and tabulated in Table 3.5.

Table 3. 5: Number of storms after vertical addition

Duration in minutes	No. of Storms of Intensity(mm/Hr) or more															
	≥5	≥10	≥15	≥20	≥25	≥30	≥35	≥40	≥45	≥50	≥55	≥60	≥75	≥90	≥120	≥150
5	1965	1180	814	533	375	259	204	128	99	66	53	37	20	8	5	1
10	1854	1104	751	492	338	233	179	105	79	51	40	28	14	5	3	0
15	1528	927	614	412	281	190	140	73	53	32	23	18	8	3	2	0
20	1161	711	467	310	202	132	99	50	34	18	11	7	2	0	0	0
25	1149	703	461	307	199	130	97	49	33	17	10	6	2	0	0	0
30	1015	622	410	272	172	111	81	42	28	15	8	4	2	0	0	0
40	753	449	290	189	121	82	57	29	20	12	8	4	2	0	0	0
50	670	407	261	170	111	73	49	26	19	11	7	4	2	0	0	0
60	482	300	195	127	77	50	32	18	13	7	6	3	1	0	0	0
75	314	187	119	80	50	28	15	10	6	3	3	1	0	0	0	0
90	208	113	66	43	23	15	7	5	3	1	1	0	0	0	0	0
105	111	62	34	22	13	8	3	2	2	0	0	0	0	0	0	0
120	51	32	17	9	4	4	1	0	0	0	0	0	0	0	0	0

STEP 5: As given in Chapter 4, choose Design Return Period for the project area. Accordingly, determine number of storms allowed to exceed the design rainfall intensity (mm/hr). For example, the required numbers of storm events having intensity equal to or more than design intensity for once in 5 year occurrence for 29 years rainfall data will be $29/5$ i.e. 5.8 times on an average may exceed over a period of 29 years.

STEP 6: Draw a stepped line say for once in 5 year recurrence (5.8 no.) of occurrences occurring in intensity column and interpolate the corresponding duration (min) as shown in Table 3.6. Similarly, draw stepped lines for other return periods if required.

Table 3. 6: Stepped line for number of storms for 5 year storm return period

Duration in minutes	No. of Storms of Intensity(mm/Hr) or more															
	≥5	≥10	≥15	≥20	≥25	≥30	≥35	≥40	≥45	≥50	≥55	≥60	≥75	≥90	≥120	≥150
5	1965	1180	814	533	375	259	204	128	99	66	53	37	20	8	5	1
10	1854	1104	751	492	338	233	179	105	79	51	40	28	14	5	3	0
15	1528	927	614	412	281	190	140	73	53	32	23	18	8	3	2	0
20	1161	711	467	310	202	132	99	50	34	18	11	7	2	0	0	0
25	1149	703	461	307	199	130	97	49	33	17	10	6	2	0	0	0
30	1015	622	410	272	172	111	81	42	28	15	8	4	2	0	0	0
40	753	449	290	189	121	82	57	29	20	12	8	4	2	0	0	0
50	670	407	261	170	111	73	49	26	19	11	7	4	2	0	0	0
60	482	300	195	127	77	50	32	18	13	7	6	3	1	0	0	0
75	314	187	119	80	50	28	15	10	6	3	3	1	0	0	0	0
90	208	113	66	43	23	15	7	5	3	1	1	0	0	0	0	0
105	111	62	34	22	13	8	3	2	2	0	0	0	0	0	0	0
120	51	32	17	9	4	4	1	0	0	0	0	0	0	0	0	0

STEP 7: Intensity duration as interpolated in Step 6 is given in the Table 3.7.

Table 3. 7: Intensity Duration for Storm of once in 5 year

Duration (min)	Intensity (mm/hr)
116.83	25
112.87	30
94.12	35
87.3	40
75.5	45
64.12	50
60.5	55
25.25	60
16.75	75
8.5	90

STEP 8: Establish Intensity Duration Frequency relationship

IDF relationship formulae are empirical ones that were developed based on the observation that as the time duration of storm increases the intensity of storm decreases. Bernard equation is commonly adopted i.e. $I = \frac{a}{t^n}$ for Indian conditions. The constants of the equation are found out by the curve fitting technique, which is described as follows:

The equation $I = \frac{a}{t^n}$ on logarithmic scale turns into the following form which is a straight line equation,

$$\log I = \log a - n \log t \quad (3.1)$$

Where,

I : Intensity of rainfall (mm/hr)
 T : Rainfall duration (min)
 a and n : Constant

Thus by plotting I and t on log-log graph paper, the trend line can be approximated to a straight line of best fit. The slope of this line will give the value of 'n' and its intercept on Y-axis will give the value of 'a'.

For example, Intensities durations analysed for 5 year return period for Bhubaneswar town as tabulated and given in the Table 3.7 is plotted on log – log paper. Constants 'a' and 'n' are determined.

Table 3. 8: Log – log graph between Intensity Duration for Storm Return Period for once in 5 year

Duration (min)	Intensity (I) (mm/hr)
116.83	25
112.87	30
94.12	35
87.3	40
75.5	45
64.12	50
60.5	55
25.25	60
16.75	75
8.5	90

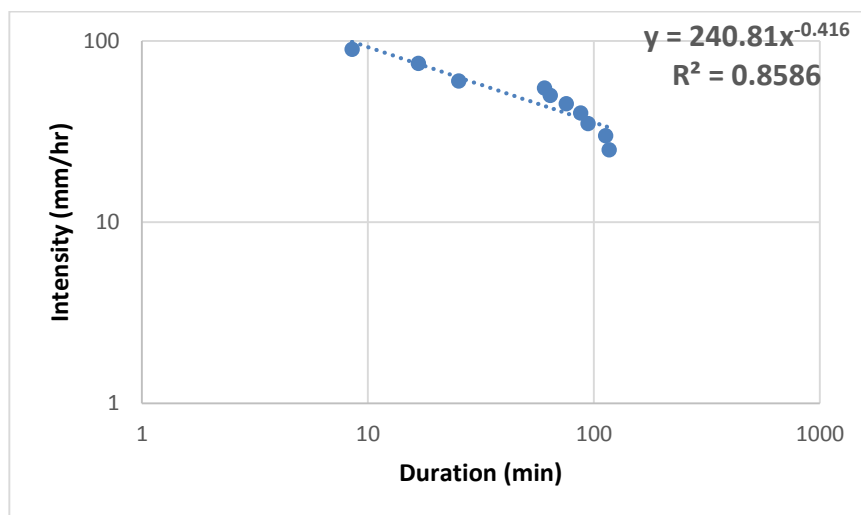

From the log – log graph, **a and n** values can be read as **240.81 and 0.416** respectively.

STEP 9: After the constants are determined, the intensities for various durations such as 5, 10, 15, 20, minutes and so on can be determined by Bernald Equation i.e. $I = \frac{a}{t^n}$. Intensities and durations so computed are plotted on arithmetic graph paper and joined with smooth curve to trace the IDF curve of given frequency as carried out in Table 3.9.

Table 3.9: IDF for Storm of Once in a 5 Year

Duration (min)	Intensity (mm/hr)
5	123.28
10	92.40
15	78.06
20	69.25
25	63.11
30	58.50
35	54.87
40	51.91
45	49.42
50	47.30
60	43.85
70	41.13
80	38.90
90	37.04
100	35.45
110	34.08
120	32.87

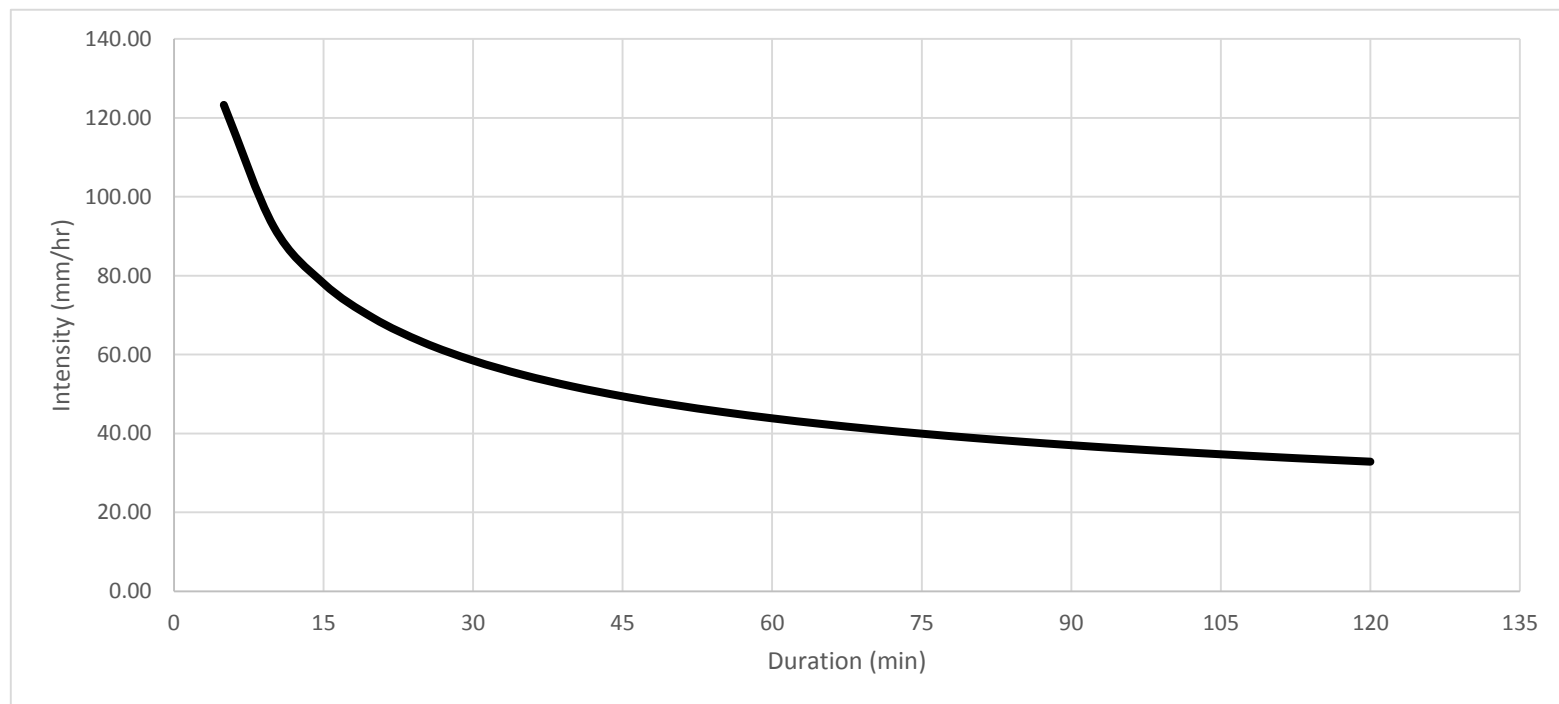

Similarly, IDF curves for other return periods can be prepared.

3.4.2 Other Method of Rainfall Analysis

IMD provides SRRG Chart or Table for 15 min interval Depth – Duration point rainfall data. The following method may also be employed for rainfall analysis to get more accurate results:

1. Collect continuous observed rainfall data in successive 15 min intervals from IMD for a fairly long period (minimum 25-30 years) or more.
2. Analyse one rainfall event into depth and duration for 15 min, 30 min, 45 min and so on as analysed in the following example given in Table 3.10 for 90 min rainfall event.

Table 3. 10: Rainfall Analysis of single storm

Time interval – 15 min (min)	Rainfall in mm – 15 mm	Successive interval rainfall Depth – 30 min	Successive interval rainfall Depth – 45 min	Successive interval rainfall Depth – 60 min	Successive interval rainfall Depth – 75 min	Successive interval rainfall Depth – 90 min
0	0					
15	4					
15	8	12				
15	16.5	24.5	28.5			
15	11.5	28	36	40		
15	7	18.5	35	43	47	
15	10.5	17.5	29	45.5	53.5	57.5

Similarly, analyse all rainfall events into depths and corresponding duration occurring during the entire sample size and convert the depths into intensity.

3. Sort out and tabulate numbers of storms of various intensities as analysed above for corresponding durations and from the observed storm events of the entire sample size as shown in table 3.11.

Table 3. 11: Number of storms of intensities against corresponding duration

Duration (min)	10-20 mm/hr	20-30 mm/hr	30-40 mm/hr	40-50 mm/hr	50-60 mm/hr	60-70 mm/hr	70-80 mm/hr	80-90 mm/hr	90-100 mm/hr	100-110 mm/hr	110-120 mm/hr	120-130 mm/hr	I > 130 mm/hr
	<i>No. of storms of intensity for 25 Year</i>												
15	419	263	165	76	44	24	33	8	2	2	2	1	1
30	126	130	87	49	30	16	10	3	3	1	2		
45	48	54	54	24	14	11	1	2	3				
60	31	26	25	19	7	4	1	2					
75	18	6	15	11	5	1	1						
90	8	3	8	9	4	1							

4. Add the number of occurrences of Rainfall Intensities equal or exceeded against corresponding duration. For instance in Table 3.11, number of storms corresponding to 15 min duration is added as $419 + 263 + 165 + 76 + 44 + 24 + 33 + 8 + 2 + 2 + 2 + 1 + 1 = 1040$.

Table 3. 12: Number of storms of intensity or more against corresponding duration

Duration (min)	10	20	30	40	50	60	70	80	90	100	110	120	130
	<i>No. of storms of intensity or more for a period 25 Year</i>												
15	1040	621	358	193	117	73	49	16	8	6	4	2	1
30	457	331	201	114	65	35	19	9	6	3	2		
45	211	163	109	55	31	17	6	5	3				
60	115	84	58	33	14	7	3	2					
75	57	39	33	18	7	2	1						
90	33	25	22	14	5	1							

5. Subsequently, the procedure for IDF curve preparation is same as given in Step 5 to Step 9 of section 3.4.1

3.5 Probabilistic Method

The variability of hydrologic data is partly deterministic and partly random. Such random variables can be well predicted by Probabilistic methods such as Gumbel Distribution or Log Pearson Type III Distribution Method. Therefore method of frequency analysis by Gumbel method which is widely used in India has been applied for construction of IDF Curve as described below:

- a) Normal Distribution
- b) Log-Normal Distribution
- c) Gumbel Extreme Value Distribution
- d) Log Pearson Type III Distribution

3.5.1 Normal Distribution and Log Normal Distribution

The normal and log-normal distribution can only give good results if the skewness coefficient of data series is equal to zero. As rainfall data can hardly comply with these conditions, hence it is commonly not applied for frequency analysis of such data.

3.5.2 Gumbel Extreme Value Distribution

The extreme value distribution introduced by Gumbel is commonly known as Gumbel distribution. It is widely used probability distribution function for extreme values in hydrologic and meteorological studies for prediction of flood peak and maximum rainfall etc. Gumbel distribution is widely used in Indian sub-continent. Therefore, the process of the analysis is described below:

The equation is given as

$$X_T = u + \alpha y_T \quad (3.2)$$

Where u and α are the mode of distribution and sample moments respectively which is given by the following equation.

$$u = \bar{X} - 0.5772\alpha \quad (3.3)$$

$$\alpha = \left(\frac{\sqrt{6}}{\pi}\right)\sigma \quad (3.4)$$

A reduced variate y_T for a return period can be defined as

$$y_T = -\ln \left[\ln \left(\frac{T}{T-1} \right) \right] \quad (3.5)$$

Where,

X_T : T year return period value

\bar{X} : Mean of the N observations

σ : Standard deviation of N observations = $\sqrt{\frac{(X - \bar{X})^2}{N-1}}$

X : Rainfall Event

T : Recurrence interval (Storm Return Period)

N : Sample size

3.5.2.1 Construction of IDF curve by Gumbel Distribution method

Rainfall Data has been obtained from IMD of the Safdarjung rain gauge station. Following steps are to be taken for the construction of IDF Curve by Gumbel Method:

Step 1: Determine the maximum depth of rainfall of each rainfall event for 15,30,45,60.....minutes interval occurring on one day, i.e. 25.7.1982 as given in Table 3.13

Table 3. 13: Maximum rainfall depth

Time interval – 15 min (min)	Successive interval rainfall Depth– 15 mm	Successive interval rainfall Depth – 30 min	Successive interval rainfall Depth – 45 min	Successive interval rainfall Depth – 60 min	Successive interval rainfall Depth – 75 min	Successive interval rainfall Depth – 90 min
0	0					
15	4					
15	8	12				
15	16.5	24.5	28.5			
15	11.5	28	36	40		
15	7	18.5	35	43	47	
15	10.5	17.5	29	45.5	53.5	57.5
Max Rainfall	<u>16.5</u>	<u>28</u>	<u>36</u>	<u>45.5</u>	<u>53.5</u>	<u>57.5</u>

Similarly, determine maximum rainfall depth and duration for all rainfall events occurring each day for the entire year and then find out the maximum rainfall depth and duration occurring in the year for 15,30,45...minutes for 25 years.

Step-2: Similarly, maximum rainfall depths of each year for 15,30,45,60.....minutes duration is obtained for entire sample size i.e. 25 years, and thus annual maximum series has been prepared as given in Table 3.14.

Table 3. 14: Maximum annual series Rainfall Depth (mm)

Year	15 min	30 min	45 min	60 min	75 min	90 min
1979	21.5	25.5	32.5			
1980	16.5	26	38	40.2	25.3	28.6
1981	13.5	18	24	19.5	23	26
1982	21	37.5	43.2	47	53.5	57.5
1983	10.6	18.6	16.6	20.3		
1984	27	41.5	58			
1985	18.8	34.8	34	45	49	
1986	21.5	41	16.3	19.5	23.3	
1987	18.5	26				
1988	20.2	22.7	20.5	23.5		
1989	22	40	47.5	52.8	42	45
1990	35.8	55.8	85.8	109.8	125.8	135.8
1991	20.7	27.5	34	44	50.5	
1992	22	34	38.2	40.2	39	
1993	18.5	26	30	36.5	41.5	50
1994	41	56	61.5	56		
1995	19	30.5	40.5	45		
1996	18	36	50	61	17.3	19.8
1997	34	25	34	38.3	21	23
1998	30	50	70	82	86.5	91.5
1999	18					
2000	20	32.5	50.3	60.3	55	61.5
2001	27	28	47	53		
2002	29	30	32.5	15.2	19	23.6
2003	30	40	37.8	28		

Step-3: Gumbel distribution is applied on the above tabulated annual series to obtain maximum values for annual rainfall depth corresponding to 15,30,45,60....minutes duration for 5 years storm return period and subsequently converted into intensity as shown in the table 3.15.

Table 3. 15: Computation using Gumbel distribution method

	15 min	30 min	45 min	60 min	75 min	90 min
Mean (\bar{X})	22.96	33.45	40.97	44.62	44.78	51.12
Standard Deviation (σ)	7.12	10.38	16.74	22.38	29.14	35.57
$\alpha = \left(\frac{\sqrt{6}}{\pi}\right)\sigma$	5.549	8.09	13.05	17.44	22.71	27.72
$u = \bar{X} - 0.5772\alpha$	19.76	28.78	33.44	34.55	31.67	35.12
For T = 5 years						
$y_T = -\ln \left[\ln \left(\frac{T}{T-1} \right) \right]$	1.5	1.5	1.5	1.5	1.5	1.5
$X_T = u + \alpha y_T$	28.08	40.92	53.01	60.72	65.74	76.7
Intensity in mm/hr	112.3	81.83	70.68	60.72	52.59	51.13

Step 4: Plot Intensity Duration Frequency for the above obtained values:

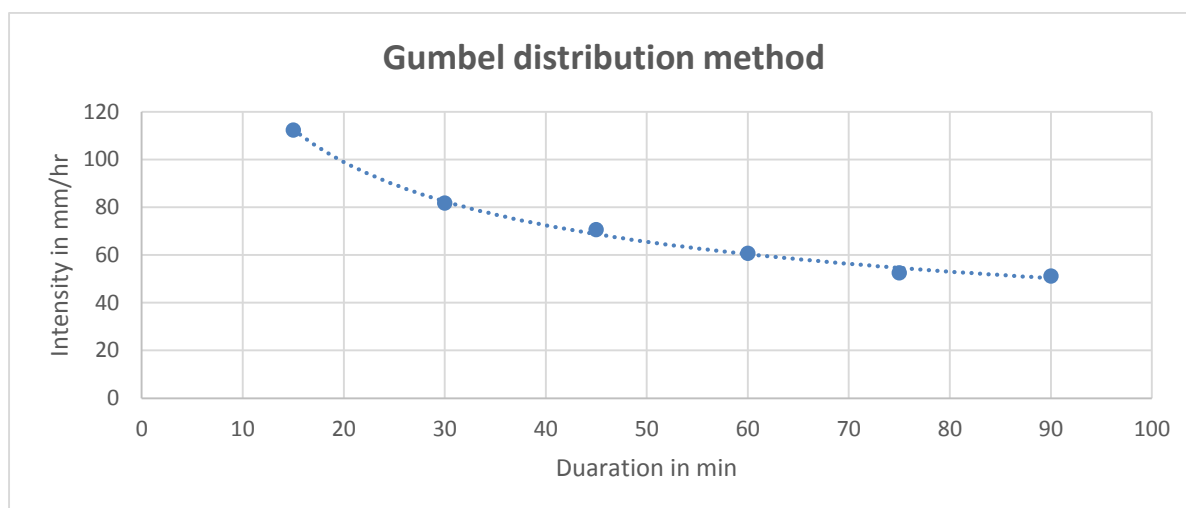

Figure 3.5: IDF curve for 5 year Return Period

3.5.3 Log Pearson Type III Distribution

Log Pearson type III distribution is widely used for frequency analysis for stream flows and can also be used for rainfall. The values obtained by Log Pearson type III distribution is more satisfactory as it has three-parameter distribution that considers mean, standard deviation, and skewness of data series. Process of computations described as follows:

- The variate (data series) is transformed into a logarithmic form either on base (10 or e), and the transformed data is then analysed.
- If X is the variate of random hydrologic series then the series of Z variates where $Z = \log X$

For this Z series, for any recurrence interval, T, the equation

$$Z_T = \bar{Z} + K_Z \sigma \quad (3.6)$$

Where,

K_Z : Frequency factor which is function of recurrence interval T and coefficient of skew C_s

σ : Standard deviation of Z variate sample $\left[\frac{\sum(Z-\bar{Z})^2}{N-1} \right]^{1/2}$

C_s : Coefficient of skew of variate Z = $N \left[\frac{\sum(Z-\bar{Z})^3}{(N-1)(N-2)\sigma^3} \right]^{1/3}$

\bar{Z} : Mean of the Z values

N : sample size

The variation of $K_Z = f(C_s, T)$ is given in Table 3.16 and Table 3.17

After finding out Z_T , the corresponding value of X_T can be obtained by taking antilog of Z_T

Table 3.16: Kz values for Pearson Type III distribution (Positive Skew)

Skew coefficient C_s	Return period in years						
	2	5	10	25	50	100	200
	Exceedance probability						
	0.50	0.20	0.10	0.04	0.02	0.01	0.005
3.0	-0.396	0.420	1.180	2.278	3.152	4.051	4.970
2.9	-0.390	0.440	1.195	2.277	3.134	4.013	4.909
2.8	-0.384	0.460	1.210	2.275	3.114	3.973	4.847
2.7	-0.376	0.479	1.224	2.272	3.093	3.932	4.783
2.6	-0.368	0.499	1.238	2.267	3.071	3.889	4.718
2.5	-0.360	0.518	1.250	2.262	3.048	3.845	4.652
2.4	-0.351	0.537	1.262	2.256	3.023	3.800	4.584
2.3	-0.341	0.555	1.274	2.248	2.997	3.753	4.515
2.2	-0.330	0.574	1.284	2.240	2.970	3.705	4.444
2.1	-0.319	0.592	1.294	2.230	2.942	3.656	4.372
2.0	-0.307	0.609	1.302	2.219	2.912	3.605	4.298
1.9	-0.294	0.627	1.310	2.207	2.881	3.553	4.223
1.8	-0.282	0.643	1.318	2.193	2.848	3.499	4.147
1.7	-0.268	0.660	1.324	2.179	2.815	3.444	4.069
1.6	-0.254	0.675	1.329	2.163	2.780	3.388	3.990
1.5	-0.240	0.690	1.333	2.146	2.743	3.330	3.910
1.4	-0.225	0.705	1.337	2.128	2.706	3.271	3.828
1.3	-0.210	0.719	1.339	2.108	2.666	3.211	3.745
1.2	-0.195	0.732	1.340	2.087	2.626	3.149	3.661
1.1	-0.180	0.745	1.341	2.066	2.585	3.087	3.575
1.0	-0.164	0.758	1.340	2.043	2.542	3.022	3.489
0.9	-0.148	0.769	1.339	2.018	2.498	2.957	3.401

Skew coefficient C_s	Return period in years						
	2	5	10	25	50	100	200
	Exceedance probability						
	0.50	0.20	0.10	0.04	0.02	0.01	0.005
0.8	-0.132	0.780	1.336	1.993	2.453	2.891	3.312
0.7	-0.116	0.790	1.333	1.967	2.407	2.824	3.223
0.6	-0.099	0.800	1.328	1.939	2.359	2.755	3.132
0.5	-0.083	0.808	1.323	1.910	2.311	2.686	3.041
0.4	-0.066	0.816	1.317	1.880	2.261	2.615	2.949
0.3	-0.050	0.824	1.309	1.849	2.211	2.544	2.856
0.2	-0.033	0.830	1.301	1.818	2.159	2.472	2.763
0.1	-0.017	0.836	1.292	1.785	2.107	2.400	2.670
0.0	0	0.842	1.282	1.751	2.054	2.326	2.576

Table 3.17: K_z values for Pearson Type III distribution (Negative Skew)

Skew coefficient C_s	Return period in years						
	2	5	10	25	50	100	200
	Exceedance probability						
	0.50	0.20	0.10	0.04	0.02	0.01	0.005
-0.1	0.017	0.846	1.270	1.716	2.000	2.252	2.482
-0.2	0.033	0.850	1.258	1.680	1.945	2.178	2.388
-0.3	0.050	0.853	1.245	1.643	1.890	2.104	2.294
-0.4	0.066	0.855	1.231	1.606	1.834	2.029	2.201
-0.5	0.083	0.856	1.216	1.567	1.777	1.955	2.108
-0.6	0.099	0.857	1.200	1.528	1.720	1.880	2.016
-0.7	0.116	0.857	1.183	1.488	1.663	1.806	1.926
-0.8	0.132	0.856	1.166	1.448	1.606	1.733	1.837
-0.9	0.148	0.854	1.147	1.407	1.549	1.660	1.749
-1.0	0.164	0.852	1.128	1.366	1.492	1.588	1.664
-1.1	0.180	0.848	1.107	1.324	1.435	1.518	1.581
-1.2	0.195	0.844	1.086	1.282	1.379	1.449	1.501
-1.3	0.210	0.838	1.064	1.240	1.324	1.383	1.424
-1.4	0.225	0.832	1.041	1.198	1.270	1.318	1.351
-1.5	0.240	0.825	1.018	1.157	1.217	1.256	1.282
-1.6	0.254	0.817	0.994	1.116	1.166	1.197	1.216
-1.7	0.268	0.808	0.970	1.075	1.116	1.140	1.155
-1.8	0.282	0.799	0.945	1.035	1.069	1.087	1.097
-1.9	0.294	0.788	0.920	0.996	1.023	1.037	1.044
-2.0	0.307	0.777	0.895	0.959	0.980	0.990	0.995
-2.1	0.319	0.765	0.869	0.923	0.939	0.946	0.949
-2.2	0.330	0.752	0.844	0.888	0.900	0.905	0.907
-2.3	0.341	0.739	0.819	0.855	0.864	0.867	0.869
-2.4	0.351	0.725	0.795	0.823	0.830	0.832	0.833

Skew coefficient C_s	Return period in years						
	2	5	10	25	50	100	200
	Exceedance probability						
	0.50	0.20	0.10	0.04	0.02	0.01	0.005
-2.5	0.360	0.711	0.771	0.793	0.798	0.799	0.800
-2.6	0.368	0.696	0.747	0.764	0.768	0.769	0.769
-2.7	0.376	0.681	0.724	0.738	0.740	0.740	0.741
-2.8	0.384	0.666	0.702	0.712	0.714	0.714	0.714
-2.9	0.390	0.651	0.681	0.683	0.689	0.690	0.690
-3.0	0.396	0.636	0.666	0.666	0.666	0.667	0.667

3.5.3.1 Construction of IDF curve by Log Pearson type III method

The same data series which has been analysed for Gumbel distribution as given in Table 3.14 has been used for Log Pearson type III method.

The data series has been transformed in logarithmic series, and the computation is done as per the given Table 3.18.

Table 3.18: Computation using Log Pearson type III method

	15 min	30 min	45 min	60 min	75 min	90 min
Mean (\bar{z})	3.0894	3.4656	3.6323	3.6818	3.6385	3.7465
Standard Deviation (σ)	0.305	0.304	0.418	0.503	0.575	0.624
Coefficient of Skewness (C_s)	0.011	-0.031	0.722	1.054	-2.791	-2.593
T = 5 years						
K from WRC 1981 with Coefficient of Skewness (C_s)	0.84134	0.84014	0.7878	0.75098	0.66735	0.69735
$z_T = \bar{z} + K_z \sigma$	3.34601	3.721	3.9616	4.05954	4.02223	4.18165
$X_T = \exp(\bar{z} + K_z \sigma)$	28.389	41.306	52.541	57.948	55.825	65.474
Intensity in mm/hr	113.56	82.61	70.06	57.95	44.66	43.65

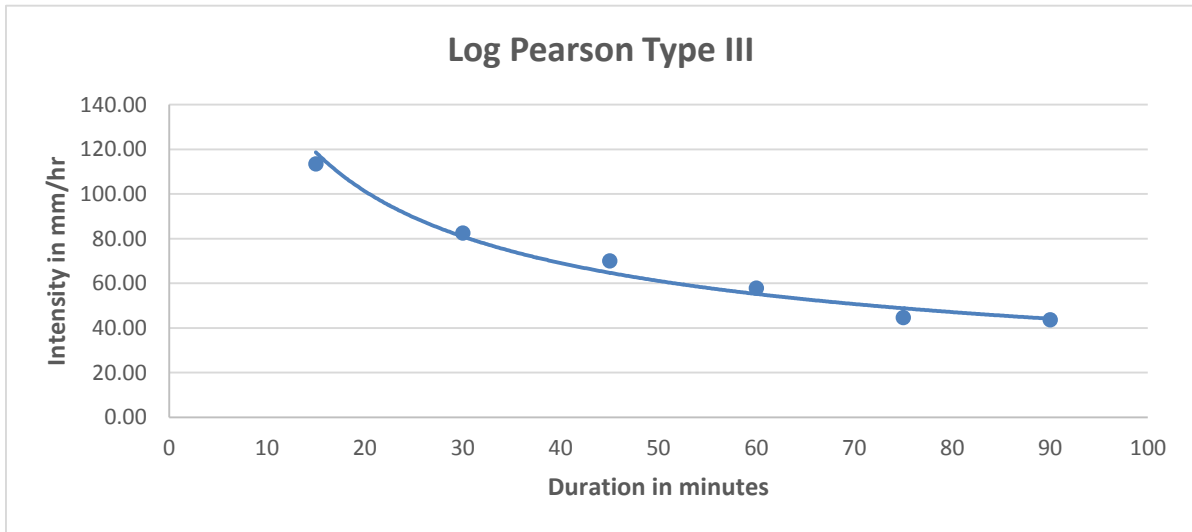

Figure 3. 6: IDF curve from Log Pearson Type III

3.6 Translation of IDF curve into rainfall hyetograph

Hyetograph is a plot of rainfall depth against the time duration. It is usually represented as a bar chart. The Hyetograph translated from IDF curve can be used in SWMM model for calculating runoff from the catchment for which IDF curve is constructed. The Hyetograph can also be superimposed upon unit Hydrograph for a given catchment to compute the direct runoff hydrograph provided the IDF curve relates to that catchment. Time area method also uses Hyetograph for computation of runoff from the catchment.

The alternating block method is a simple way to develop a rainfall hyetograph from an intensity duration curve for a given storm return period as described in the book 'Applied Hydrology by Ven Te Chow.' The rainfall hyetograph generated by this method specifies the precipitation depth occurring in n successive time intervals of duration δ_t over a total duration of $T_d = n\delta_t$. The intensity from a given return period is read from the IDF curve for each of the duration, and corresponding precipitation depth is found as product of intensity and duration. By taking difference between successive precipitation depth values, the amount of precipitation to be added for each additional unit of time δ_t is found. These increments or blocks are recorded into a time sequence with maximum intensity occurring at the centre of the required duration T_d , and the remaining blocks are arranged in descending order alternately to the right and left of the central block to form the required rainfall hyetograph as shown in the Table 3.19.

Using the data of Intensity and duration, a sample Hyetograph is prepared as follows:

Table 3. 19: Computation to prepare Hyetograph

Duration (minutes)	Intensity (mm/hr)	Successive Depth. (mm)	Incremental Depth (mm)	Time (Minutes)	Precipitation (mm)
10	151.38	25.23	25.23	0-10	4.27
20	108.61	36.20	10.97	10-20	4.71
30	89.44	44.72	8.52	20-30	5.36
40	77.92	51.95	7.23	30-40	6.41
50	70.03	58.36	6.41	40-50	8.52
60	64.17	64.17	5.81	50-60	25.23
70	59.6	69.53	5.36	60-70	10.97
80	55.91	74.55	5.01	70-80	7.23
90	52.84	79.26	4.71	80-90	5.81
100	50.24	83.73	4.47	90-100	5.01
110	48	88.00	4.27	100-110	4.47
120	46.04	92.08	4.08	110-120	4.08

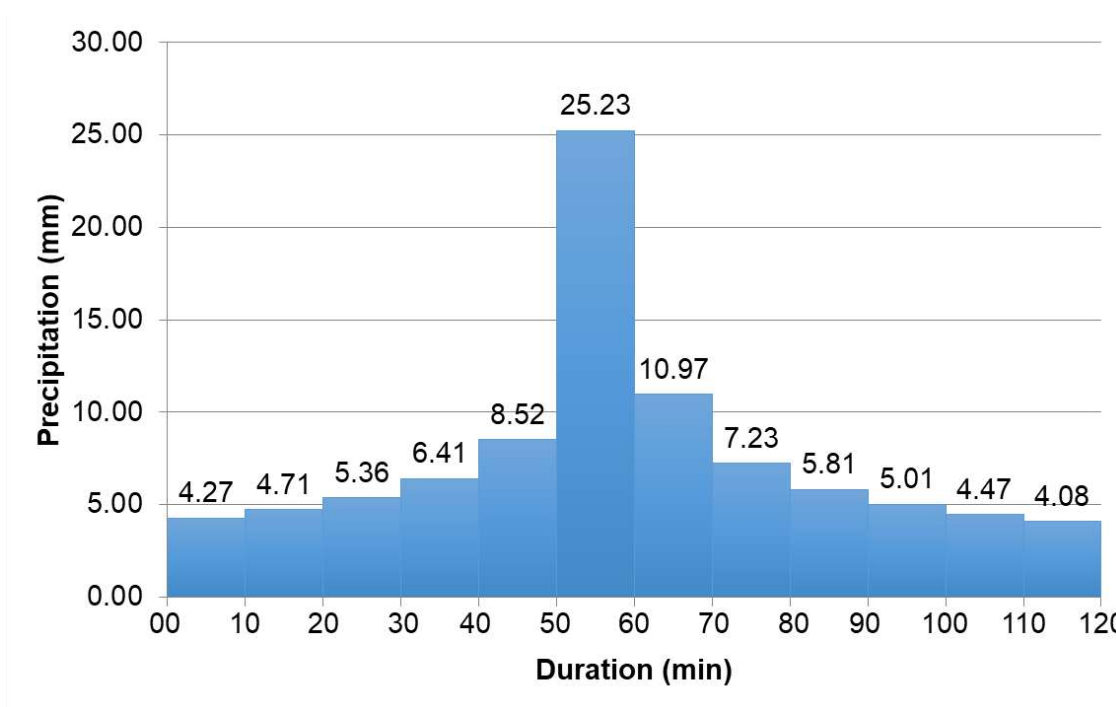

Figure 3.7: Hyetograph

CHAPTER 4: RUNOFF ESTIMATION

4.1 General

The essential requirement for designing of Storm Water Drainage system is the proper estimation of storm runoff to downstream drains or the point of disposal. It has a bearing on optimizing the cost of infrastructure as well as its performance. The parameters like rainfall intensity, imperviousness factor, runoff coefficient, recurrence period, climate change, and identification/zoning of drainage catchment play an important role. In chapter 3, the analysis of rainfall has been dealt in detail. In this chapter various methods of estimation of storm runoff like Rational Method, Time Area Method, Unit Hydrograph Method, and Rainfall-Runoff Simulation method are explained.

4.2 Storm Runoff

Runoff from a catchment is that fraction of precipitation which generates surface flow. It thus represents the output from the catchment corresponding to precipitation in a given unit of time. For given precipitation, initial losses due to the interception, evapotranspiration, infiltration and detention storage requirements have to be first satisfied before the commencement of runoff. After these losses are met, the excess rainfall moves over the surface termed as storm runoff. This is illustrated in Figure 4.1.

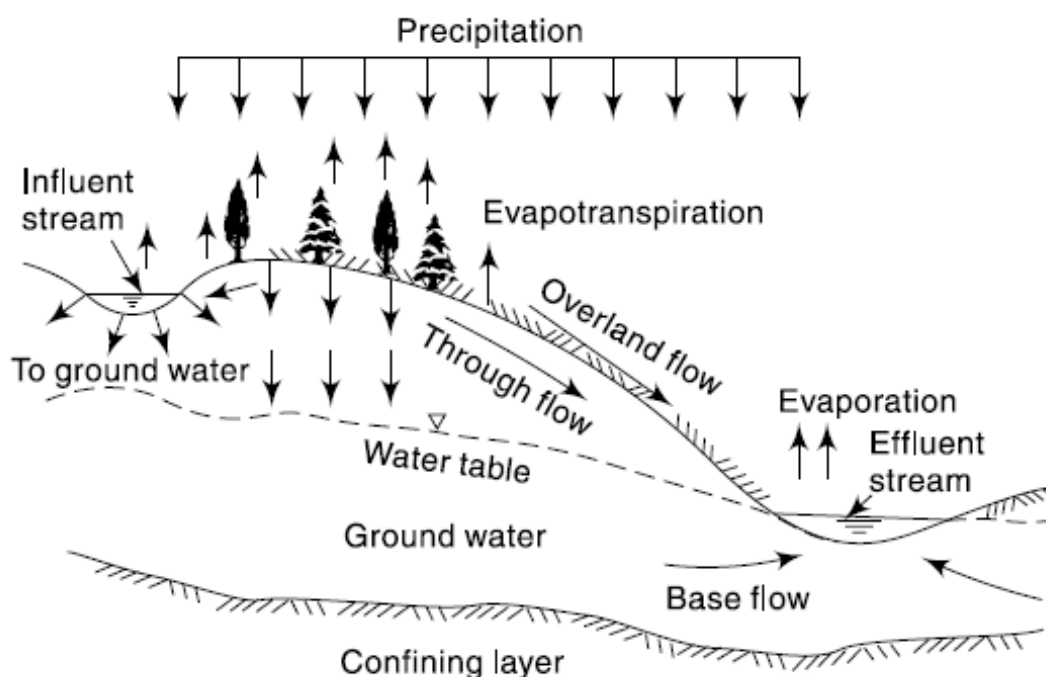

Figure 4.1: Different routes of runoff

4.3 Factors affecting runoff

The runoff estimation is affected by the following factors of catchment hydrology:

- a) Size of Catchment
- b) The shape of the Catchment, i.e., Fan-shaped, Fern shaped, Irregular Shaped, etc.
- c) Elevation of the Catchment
- d) Drainage Density
- e) Type of soil of the catchment
- f) Type of cover viz. paved, unpaved, vegetative, etc.
- g) Slope and orientation of the catchment
- h) Topography (Depression storages/ponds/ lakes) and geology of the catchment
- i) Saturation of soil with water due to previous precipitation if any, including the level of groundwater table.

4.4 Methods of Runoff Estimation

The following methods are generally used for runoff estimation for the design of urban storm water drainage systems.

1. Rational Method
2. Time Area Method
3. Unit Hydrograph Method
4. Rainfall-Runoff process simulation

The above methods and their use in the design of storm water networks are given below.

4.4.1 Rational Method

The rational method was developed during the second half of the 19th century for estimating design discharge from an urban catchment. Majority of urban storm drainage systems are designed based on the Rational Method, in as much as 90% cases across the globe, in spite of having several limitations.

4.4.1.1 Steps of computation for Rational Method

The procedure for the estimation of storm runoff by the rational method is mentioned in the following steps:

-
- Step 1: Obtain historical rainfall data of 30 years or more for the given project area
 - Step 2: Select a return period from Table 4.1 as required
 - Step 3: Prepare the IDF curve for the above return period as per Chapter 3
 - Step 4: Demarcate the catchment
 - Step 5: Determine the time of concentration (t_c) as described in section 4.4.1.6
 - Step 6: Determine rainfall intensity against the time of concentration from IDF curve
 - Step 7: Determine runoff coefficient (C) as described in section 4.4.1.5
 - Step 8: Calculate peak flow by Rational formula as given in section 4.4.1.3

4.4.1.2 Design flow

Storm water drains are designed, taking into account the peak flow. The peak flow is defined as the flow when the entire catchment is contributing to its outlet. This will occur when the given intensity of rainfall begins instantaneously and continues until the time of concentration.

4.4.1.3 Procedure for estimation of runoff

If properly understood and applied, the 'rational method' can produce satisfactory results for sizing storm drains, street inlets, and small on-site detention catchments. The formula for calculating peak flow is given as below:

$$Q_p = 10 C I A \quad (4.1)$$

Where,

Q_p : Peak flow at the point of design, m^3/hr

C : Runoff coefficient, dimensionless

I : Average rainfall intensity should be taken for the duration of rainfall equal to the time of concentration, mm/hr

A : Catchment area, hectares

This formula is dimensionally consistent to other measurement systems.

Although this method is widely used in storm water drainage design, the estimation of runoff involves the following assumptions:

- a) The maximum size of a catchment should be between 8 to 10 sq km
- b) Larger catchments can be sub-divided into smaller sub-catchments
- c) The peak flow occurs when the entire catchment is contributing to the flow

- d) The rainfall intensity is uniform over the entire catchment
- e) The rainfall intensity is uniform over a time duration equal to the time of concentration
- f) The frequency of the computed peak flow is the same as that of the rainfall intensity corresponding to the return period of the 'design storm.'
- g) The coefficient of runoff is the same for all storms of all recurrence probabilities

4.4.1.4 Design Return Period

The design return period of a storm is an average period of time after which it reoccurs, for a given rainfall magnitude or more corresponding to a particular duration of time. This is integral part of IDF curve developed, based on analysis of past rainfall data, for designing of storm water drainage systems. Depending on importance of the drainage area, socio-economic conditions of the city and other constraints such as funding for infrastructure and availability of space for construction of drains, the design return period of storm should be judiciously adopted in estimation of storm runoff. In view of the above, the recommended design return period of storms is given in Table 4.1 for estimation of storm runoff.

Table 4.1: Recommended Design Return Period for various types of urban catchments

S. No.	Urban Catchment	Return Period	
		Class I Cities**	Other cities***
1.	Central Business and commercial	Once in 5 years	Once in 2 years
2.	Industrial	Once in 5 years	Once in 2 years
3.	Urban Residential	Once in 5 years	Once in 2 years
4.	Airports and other critical infrastructure*	Once in 100 years	Once in 50 years

*Critical infrastructure includes Railway Stations, Power stations, etc.

** Class I Cities are cities having population 1 Lakh and above

*** Other cities are cities having population less than 1 lakh

Note:

1. It may not be always feasible to design / retrofit the storm water drains for the recommended return period in all the cities. In cases where redesigning / retrofitting is not feasible as per recommended return period due to city profile / site constraints, efforts should be made to adopt recommended return period by adopting 'Best Management Practices, (BMP) like in-situ rainwater harvesting methods within premises / plots, along the storm water channels / conduits and storm retention/ detention structures to accommodate the excess runoff. However, the preferred return period shall be as per those recommended in the Table 4.1 above.

2. Under exceptional circumstances, a high powered committee constituted by State / UT Government through a notification may justify the adoption of higher return period considering techno-economical and socio-environmental conditions than the one recommended in Table 4.1 after exploring various other available options to meet the design requirements.

4.4.1.5 Runoff Coefficient

The coefficient of runoff (C), is a function of the nature of surface and assumed to be the same for all storms of all recurrence probabilities. Recommended values of C on various surface types of the catchments are given in Table 4.2. While choosing the values for C, the ultimate development of the catchment as per the master plan should be taken into consideration.

Table 4.2: Runoff co-efficient of various surfaces

S. No.	Type of Area	Runoff Coefficient
1	Commercial Area	0.70 – 0.95
2	Industrial Area	0.60 – 0.90
3	Institutional Area	0.70 – 0.95
4	Residential Area -High Density -Low Density	0.60 - 0.75 0.40 - 0.60
5	Recreational areas	0.10 - 0.25
6	Pavement - Asphaltic Pavement - Concrete Pavement - Brick Pavement	0.70 - 0.95 0.80 – 0.95 0.70 - 0.85
7	Roof Catchment - Tiles - Corrugated metal sheets - Concrete	0.8-0.9 0.7-0.9 0.7-0.90

Source: Adapted from ASCE and WPCF 1969

Whereas the use of the runoff coefficient implies there is a constant ratio of rainfall to runoff, the actual ratio will vary over the course of a storm due to the condition of the area and the variability of the rainfall pattern. A common practice is to use average coefficients for various types of areas and assumed that the coefficients will be constant throughout the duration of the storm.

Weighted average runoff coefficient of catchment area containing different character of surfaces for a flow concentrating at a point may be estimated as follows:

Weighted average of 'C' values of different type of urban surfaces should be calculated by the following formula

$$C = \frac{C_1A_1 + C_2A_2 + C_3A_3 + \dots}{A_1 + A_2 + A_3 + \dots} \quad (4.2)$$

Where,

$C_1, C_2, C_3 \dots$ are runoff coefficients of urban surfaces

$A_1, A_2, A_3 \dots$ are areas of respective urban surfaces

4.4.1.6 Time of Concentration in storm drainage system (t_c)

The rainfall intensity (I) in the rational formula is the average rainfall intensity over a given duration **equal to the time of concentration** for the drainage area. The rainfall intensity for the design storm can be obtained from the IDF relationship described in Chapter 3.

The time of concentration (t_c) is defined as flow travel time taken from the hydraulically most remote point in the contributory catchment to the point under consideration. The time of concentration for drain sizing is the time required for water to travel from the most hydraulically distant point in the total contributing catchment to the design point. Typically, this time consists of two components:

- i. Time for the surface flow to reach the first inlet, i.e., t_0
- ii. Time to flow through the storm drainage system to the point of consideration i.e. t_f .

$$t_c = t_0 + t_f \quad (4.3)$$

The inlet time is dependent on the distance of a farthest point in the drainage catchment to the inlet manhole as said above, as well as, on the shape, characteristics and topography of the catchment. It generally varies from 5 to 30 minutes in urban areas. In hilly areas the inlet time may be as low as 3 minutes, where steep slopes are encountered. However, the following formula is widely used to determine inlet time to reasonable accuracy.

4.4.1.6.1 Time of surface flow (t_0)

The formula to compute the time of surface flow has been developed by the Corps of Engineers, USA from airfield drainage data. The method was originally intended for use on airfield drainage problems but has now been used frequently for surface flow in urban catchments.

The formula to calculate time of surface flow (t_0) is given as follows:

$$t_0 = \frac{0.994 (1.1-C)L^{0.5}}{S^{0.333}} \quad (4.4)$$

Where,

t_0 : Time of surface flow (Minutes)

C : Rational Method runoff coefficient

L : Length of surface flow (m)

S : Surface Slope, in percentage (%)

Note: If slope (S) is expressed as a ratio, then the formula to be applied is

$$t_0 = \frac{0.218 (1.1-C)L^{0.5}}{S^{0.333}} \quad (4.5)$$

4.4.1.6.2 Time of flow (t_f)

$$t_f = \frac{L_{\text{drain}}}{V} \quad (4.6)$$

The velocity of flow in m/s is computed from the Manning's equation

$$V = \frac{1}{n} R^{0.67} S^{0.5} \quad (4.7)$$

Where,

V : Velocity of Flow, m/sec

t_f : Time of travel, minutes

n : Manning's roughness coefficient

R : Hydraulic radius, m

S : Longitudinal slope

4.4.1.7 Partial Area Effect

In general, the appropriate time of concentration (t_c) for calculation of the flow at any point is the longest time of travel to that point. However, in some situations, the maximum flow may occur when only part of the upstream catchment is contributing. Thus the product of runoff coefficient, lesser catchment area and higher rainfall intensity which is resulting from a lower t_c may produce a greater peak discharge than

that if the whole upstream catchment is considered. This is known as the 'partial area effect'.

This can occur in 2 cases as described below:

- i. The first case occurs when a highly impervious section exists at the most downstream area of a watershed and the total upstream area flows through the lower impervious area. When this occurs, two separate calculations should be made. First, calculate the runoff from the total drainage area with its weighted C value and the intensity associated with the longest time of concentration. Second, calculate the runoff using only the smaller impervious area. The typical procedure would be followed using the C value for the small impervious area and the intensity associated with the shorter time of concentration. Compare the results of these two calculations and use the largest value of discharge for design.
- ii. The second case occurs when a smaller, impervious area is tributary to the larger primary watershed of less impervious area. When this occurs, two sets of calculations should also be made. First, calculate the runoff from the total drainage area with its weighted C value and the intensity associated with the longest time of concentration. Second, calculate the runoff to consider how much discharge from the larger primary area is contributing at the same time as the peak from the smaller, impervious tributary area. When the small area is discharging, some discharge from the larger primary area is also contributing to the total discharge. In this calculation, use the intensity associated with the time of concentration from the smaller impervious area. The portion of the larger primary area to be considered is determined by this equation:

$$A_c = A \frac{t_{c1}}{t_{c2}} \quad (4.8)$$

Where,

A_c : Smaller impervious tributary area to the larger drainage area

A : Larger drainage area

t_{c1} : Time of concentration of the tributary area

t_{c2} : Time of concentration of larger drainage area

An illustrative example is given in Appendix A 4.1.

4.4.2 Time Area Method

This method applies a convolution of the rainfall excess hyetograph with a time area diagram representing the progressive area contributions within a catchment in set time increments to generate runoff hydrograph of total flow to be routed through urban drain network.

4.4.2.1 Travel Time

The excess rainfall over the catchment causes surface flow that passes through a catchment channel to the point of catchment outlet. The time taken for surface flow from different points to the catchment outlet in the drainage catchment is called travel time. The time will be evidently more for remote points of the catchment and will be lesser for the points nearer to the catchment outlet. These points can be earmarked on the catchment from where the flow takes equal time to reach the catchment outlet. The line joining such points of equal time of travel is called isochrones. Different isochrones can be drawn expressing different time of flow, and obviously the highest value of isochrones represents the time of concentration since it is the maximum time of flow from farthest point of the catchment.

Hydrographs are generated in time area method by convolution of the rainfall excess hyetograph with a time area graph generating progressive runoff contribution from sub-catchments within the catchment in set time increments. To apply this method, the catchment is first divided into a number of time zones separated by lines of equal travel time (isochrones) to outlet, as shown in Figure 4.2.

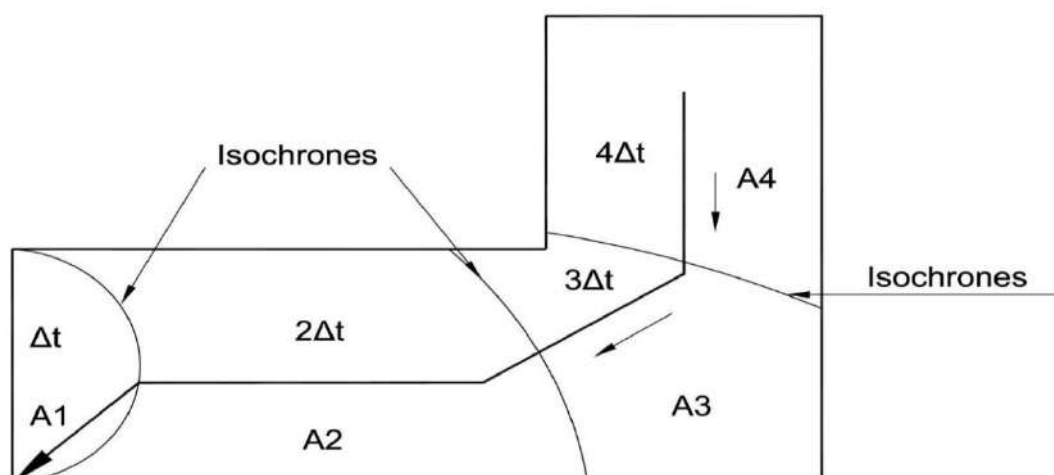

Figure 4.2: Isochrones

The ordinates of runoff hydrograph can be determined by applying each block of rainfall excess hyetograph given below in Figure 4.3 to the entire catchment.

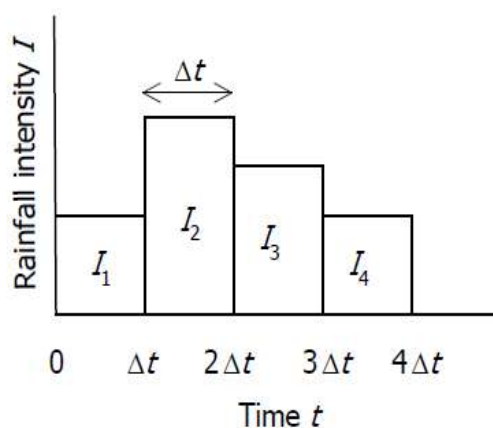

Figure 4.3: Hyetograph

The runoff from each sub-area reaches the outfall at lagged intervals defined by the time area curve, as shown below in Figure 4.4.

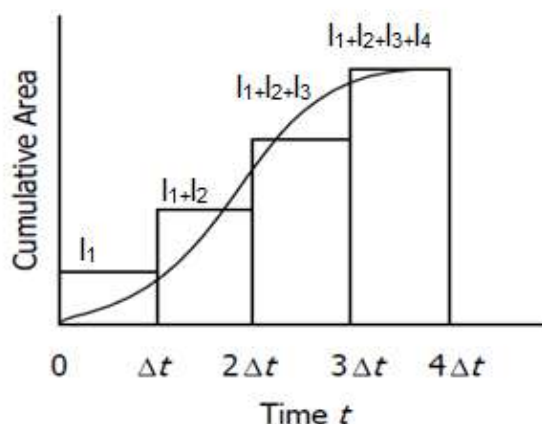

Figure 4.4: Time area curve

The simultaneous arrival of the runoff from areas A_1, A_2, A_3, A_4 caused by storm I_1, I_2, I_3, I_4 shall be determined by adequately lagging and adding runoff contributions from sub-catchments as explained below.

Travel time of each zone is Δt . Rainfall occurs over the entire catchment in time t . Now in first Δt interval, I_1 rainfall has fallen over the entire catchment, and therefore after Δt interval, the discharge at outlet is contributed by sub-catchment A_1 from rainfall I_1 .

Hence, discharge $q_1 = A_1 * I_1$

Similarly, I_2 rainfall has fallen in second Δt interval, the discharge $A_2 * I_1$ and $A_1 * I_2$ reach simultaneously at the outlet.

Hence discharge, $q_2 = A_2 * I_1 + A_1 * I_2$

Similarly by lagging and adding discharges

$$q_3 = A_3 * I_1 + A_2 * I_2 + A_1 * I_3$$

$$q_4 = A_4 * I_1 + A_3 * I_2 + A_2 * I_3 + A_1 * I_4$$

After lapse of $4\Delta t$ the rain stops and runoff generated by I_1 and I_2 are entirely drained out.

Rest of the incremental rainfalls falling over the sub-catchment subsequently reach the outlet point as given by lagging and adding sub-catchments flows hereunder.

$$q_5 = A_4 * I_3 + A_3 * I_4 + A_2 * I_5$$

$$q_6 = A_4 * I_4 + A_3 * I_5$$

$$q_7 = 0$$

A hydrograph can be developed by plotting discharges against time that can be used for designing channels/ conduits. An illustrative example is given in Appendix A 4.2.

4.4.3 Unit Hydrograph Method

The unit hydrograph method is an outcome of investigation into the geometric properties of the surface runoff portion of the hydrograph in its relation to an effective rain that has fallen during a unit time. The unit hydrograph is, therefore, defined as the hydrograph of direct runoff resulting from a unit depth (1 cm) of rainfall excess occurring uniformly over the catchment and at a uniform rate for a specified duration (D hours). A typical 30 min unit hydrograph is shown below in Figure 4.5.

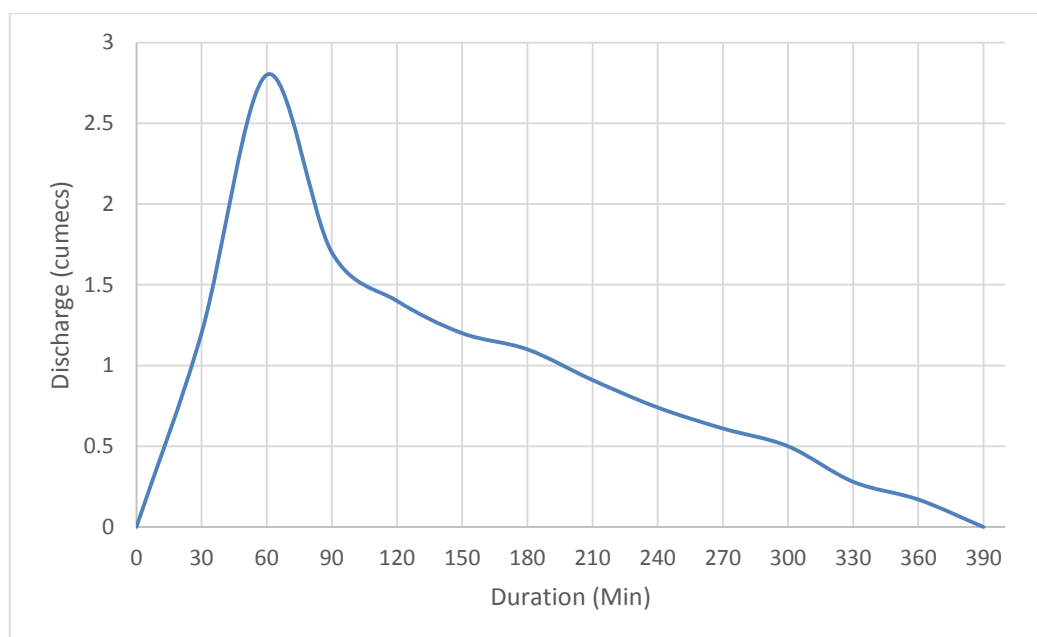

Figure 4.5: 30 min Unit Hydrograph

The unit hydrograph represents the lumped response of the catchment to a unit rainfall excess of D hr duration to produce a direct runoff hydrograph to the rainfall excess. Hence the volume of water contained in the unit hydrograph must be equal to rainfall excess which is considered 1 cm over the entire given catchment.

If the rainfall excess in a duration D hours is r times the unit depth (1 cm), the ordinates of the resulting DRH will be r times the corresponding ordinates of the D hour unit hydrograph. Since the area under the D hour DRH should be r times the area under the corresponding D hour unit hydrograph, the base of the DRH will be the same as that of the unit hydrograph.

4.4.3.1 Limitations of Unit Hydrograph

- i. The upper limit of the catchment area for the use of Unit Hydrograph is prescribed not to be more than 5000 sq km whereas the lower limit of catchment area may not be less than 200 Ha;
- ii. The catchment should not have large storages in terms of tanks, ponds, large flood bank storages, etc., which affect the linear relationship between storage and discharge;
- iii. If the precipitation is decidedly non-uniform unit hydrograph cannot be expected to give good results.

An illustrative example is given in Appendix A 4.3.

This method may not Rainfall-runoff to small urban catchments.

4.4.4 Rainfall- runoff process simulation

Following two methods for simulation of rainfall-runoff process is used for computation of storm runoff from urban watersheds:

4.4.4.1 Kinematic Wave Equation

This method is applied to describe the overland flow on the catchment considered as a wide plane with very shallow depth of flow which is technically termed as sheet flow. For a given rate of rainfall and infiltration varying discharges from unit width of the catchment can be evaluated and adding discharges of all such unit widths, total discharge varying with each time step can be computed in shape of hydrograph at the outlet of the catchment. The Saint Venant equations describe the one-dimensional unsteady flow, which is applicable in this case. In kinematic wave motion inertial and pressure forces have negligible effects; therefore continuity equation is given in equation 4.9 and Manning equation given in equation 4.10 are combined as given in equation 4.11 which is used to simulate and compute the runoff from the watershed:

$$\frac{\partial y_o}{\partial t} + \frac{\partial q_o}{\partial x} = (I - f) \quad (4.9)$$

$$q_o = \mu_o (y_o)^{m_o} \quad (4.10)$$

Where,

q_o : Variable flow per unit width of overland flow plane

μ_o : $(1/N)S_o^{0.5}$

m_o : 5/3

S_o : Average slope of overland flow

y_o : Mean depth of out flow

$(I - f)$: Rate of excess rainfall (rainfall – infiltration)

t : Time

x : Spatial coordinate

N : Manning roughness coefficient of overland flow (Values may be seen in Appendix A 5.7)

Combining equations 4.9 and 4.10, Kinematic wave equation is obtained as follows:

$$\frac{\partial y_o}{\partial t} + \mu_o m_o y_o^{(m_o-1)} \frac{\partial y_o}{\partial x} = (I - f) \quad (4.11)$$

In the application of above formulae the lateral flow is considered equal to difference between the rates of rainfall and infiltration and the overland flow is taken to be flow per unit width of the plane. The equation 4.11 has one dependable variable so that it can be solved to give a relationship for y_o in terms of x , t and excess rainfall depth $(I - f)$. Once y_o is found, it can be substituted back into equation 4.10 to obtain the value of q_o . The solution of equation 4.11 can be worked out by finite difference approximations. Nevertheless, it is easier to solve the equation by computer software to develop the runoff hydrograph at the outlet of the watershed.

Hydrologic Engineering Center (HEC), US Corps of Engineers research facility in Davis, California has developed such a computer program named HEC-1 that is widely used to develop runoff hydrograph from the watershed at its outlet.

4.4.4.2 Non Linear reservoir method

Nonlinear reservoir method for rainfall runoff simulation can also be used to compute runoff quantity for single event or long term simulation primarily from urban catchments as per governing equations discussed below.

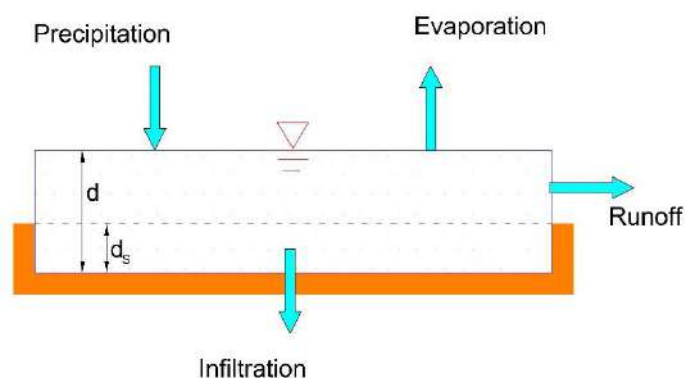

Figure 4.6: Nonlinear reservoir model

From the above Figure 4.6, the sub-catchment experiences inflow from precipitation and losses from evaporation and infiltration. The net excess ponds atop the sub catchment surface to a depth d . Pondered water above depression storage depth d_s can become runoff outflow q . Depression storage accounts for initial rainfall abstraction. From conservation of mass, the net change in depth d per unit time is the difference between inflow and out flow rates over the catchment i.e.

$$\frac{\partial d}{\partial t} = I - e - f - q \quad (4.12)$$

Where,

I : Rate of rainfall

e : Surface evaporation rate

f : Infiltration rate

q : Runoff rate

I , e , f and q are expressed as flow rate per unit area.

Assuming that flow across the sub catchment surface behaves as it were a uniform flow within a rectangular channel of width w , height $d-d_s$, and slope s . The Manning's equation can be used to express the runoff's volumetric flow Q as

$$Q = \frac{1}{N} A_X R^{2/3} S_o^{1/2} \quad (4.13)$$

Where,

N : Manning's roughness coefficient of overland flow

S : Average slope of the catchment

A_x : Area across the sub-catchment width through which the runoff flows.

Referring to figure 4.6, A_x is the rectangular area with width w and height $d-d_s$. Because w will always be much larger than d , it follows that $A_x = W * (d - d_s)$ and $R_x = (d - d_s)$

Substituting the values of R_x and A_x in equation 4.13:

$$Q = \frac{(w*s^2)^{\frac{1}{N}}}{N} * (d - d_s)^{\frac{5}{3}} \quad (4.14)$$

To obtain the runoff per unit area,

$$q = \frac{(w*s^2)^{\frac{1}{AN}}}{AN} * (d - d_s)^{\frac{5}{3}} \quad (4.15)$$

Substituting this equation into the mass balance relation given in equation 4.12:

$$\frac{\partial d}{\partial t} = I - e - f - \mu (d - d_s)^{\frac{5}{3}} \quad (4.16)$$

Where,

$$\mu = \frac{(w * s^2)^{\frac{1}{AN}}}{AN}$$

The above equation is a nonlinear differential equation for known values of I , e , f , d_s and μ . It can be solved numerically over each time step for ponded depth by numerical integration method and subsequently the value of runoff Q that can be developed in the shape of runoff hydrograph at the outlet of the catchment.

Environmental Protection Agency (US) has developed computer software named "SWMM" which is widely used to compute and develop the runoff hydrograph at the outlet of the catchment.

4.5 Climate Change effects on Urban Storm Runoff

Based on intensive research across the globe as well as those reported through IPCC, it has been established that global warming induced climate change is causing a change in rainfall precipitation pattern. Various studies in India including those by IMD also strengthen above changing pattern. It is established that rise in atmospheric temperature lead to intensifying Earth Hydrologic Cycle causing short duration heavy intensity precipitations. Each 1 deg C rise in atmospheric temperature leads to 7 % increase in water vapor in the atmosphere. Countries like the UK have already recommended an increase of 20 % in the design storm runoff to account for change in rainfall pattern due to climate change.

However, in a vast country like India, It is not feasible to assign a particular percentage increase in rainfall intensity over the one obtained from the IDF curve. This is also due to the fact that in IMD study, some rainfall stations have recorded an increase in rainfall, whereas others are showing a reduction in rainfall intensity. For accessing the percentage increase in rainfall intensity, a detailed analysis of 30 years or more is required. One of the methods to access changing trend in rainfall intensity is to break 30 years rainfall data in 3 sub-group of 10 years each and draw respective IDF curves for each sub-Group data. For a particular time of concentration of 30 minutes and 60 minutes, the rainfall intensity may be read out from IDF curves and tabulated for each sub-group period. Subsequently, using linear regression model, the changing trend in rainfall intensity can be estimated to further project design rainfall intensity and can be suitably incorporated in storm runoff estimation. In case of no increase or negative increase trend in rainfall intensity, the conventional value of intensity obtained based on analysis of 30 years rainfall data may be used.

Also, to account for the impact of climate change on rainfall and consequent change in design discharge, Intensity – Duration – Frequency curves needs to be periodically updated for a given catchment or locality intending to design new or retrofitting old storm water drains.

Additionally, increased volume of runoff from higher intensity of rainfall on account of climate change can also be channelized by implementing BMPs, LIDs etc. as recommended in Chapter 10 rather than going for large size conveyance drains.

CHAPTER 5: HYDRAULIC DESIGN OF STORM WATER DRAINS

5.1 General

The Chapter gives a broad coverage of theory and practice of open channel hydraulic in planning and design of storm water channels and conduits that convey storm runoff resulting from rainfall over urban catchments as described in Chapter 3 & Chapter 4 of this Manual. Flow equations to compute the hydraulic parameters required in designing the channels, gutters, and conduits under different flow conditions are given with illustrative examples to show the application of the flow formulae. A brief outline about design aspects of the engineered natural channels has been discussed in the final section of this chapter.

5.2 Storm water flows in Channels and Conduits

Storm water flows in channels/ conduits in contact with atmospheric air is said to be an open channel flow or free-surface flow.

If the rate of discharge remains constant with time at a given cross-section, the flow is said to be steady, and if it varies with time, then the flow is called unsteady flow.

If the velocity and depth of flow are the same at every section of channel/conduit, the steady open channel flow is said to be uniform flow, and if the velocity, depth or both are changing then the flow is known as non-uniform flow.

When fluid flows in a parallel direction without interruption between each layer, it is defined as laminar flow, and if it moves in irregular paths, it is said to be turbulent flow.

Storm water flows in open channel/conduit are under unsteady and turbulent flow conditions but to simplify the design process, it is assumed to flow in steady turbulent conditions either uniform, non-uniform gradually or rapidly varied flow.

Flow Formulae which are applicable in design computations of storm channels/ conduits are given as follows:

1. Reynolds's number

For open channel flow of any cross section:

$$Re = VR / \nu \quad (5.1)$$

For flow in pipe of diameter D

$$R_e = VD / \nu \quad (5.2)$$

Where,

R_e : Reynold's Number (Dimensionless)

V : Cross- sectional mean velocity in m/sec

D : Diameter of pipe

R : Hydraulic Radius (A/P) in m

ν : Kinematic Viscosity in m^2/sec

P : wetted perimeter in m

R_e gives a dimensionless number, which is called Reynold's number. It determines whether the flow is laminar or turbulent. It is found that in open-channel, flow is laminar when $R_e \leq 500$ and turbulent when $R_e > 1000$, whereas in pipe flow, the flow is laminar when $R_e \leq 2000$ and flow is turbulent when $R_e > 4000$.

- 2. Specific Energy E_s :** It is defined as the energy of the flow with reference to the channel bed as the datum.

$$E_s = Y + V^2/2g \quad (5.3)$$

Where,

Y : Depth of water

V : Mean cross section velocity

g : Acceleration due to gravity

E_s : Specific energy

3. Froude number

$$F_r = V / (gD_m)^{1/2} \quad (5.4)$$

Where,

F_r : Froude number (Dimensionless)

V : Mean velocity in m/sec

D_m : Hydraulic mean depth in m (cross section area of flow/width of the channel)

g : acceleration due to gravity in m/sec^2

4. Critical flow: The general equation for Critical flow:

$$Q^2B/gA^3 = 1 \quad (5.5)$$

Where,

Q : Discharge, m^3/sec

B : Width of water surface, m

A : Cross section area of water flow, m^2

g : Acceleration due to gravity, m/sec^2

For a fixed discharge, the specific energy is minimum at critical depth. For all other values of specific energy, there are two alternate depths, one is subcritical depth when flow depth is greater than critical depth and other is supercritical depth when flow depth is less than critical depth. In steady Uniform flow, the flow depth is known as normal depth. The slope at normal depth is said to be mild slope, at critical depth the slope is said to be critical slope and at supercritical depth, the slope is known as steep slope.

5. Manning's Equation

Manning's Equation for uniform gravity flow:

$$V = (1/n) \times R^{2/3} \times S^{1/2} \quad (5.6)$$

Manning's Equation for uniform flow in terms of discharge:

$$Q = (1/n) \times (A^{5/3}/P^{2/3}) \times S^{1/2} \quad (5.7)$$

For circular section:

$$Q = (0.3118/n) \times D^{8/3} \times S^{1/2} \quad (5.8)$$

Where,

V : Velocity of flow in m/sec

R : Hydraulic radius (Flow area (A)/Wetted perimeter (P)) in m .

S : Slope of Hydraulic Gradient

n : Manning's coefficient of roughness for Channels / conduits

P : Wetted perimeter in m

A : Area of cross section of water area in m^2

Q : Discharge in m³/sec

D : Diameter of pipe in m

Owing to its simplicity and acceptable degree of accuracy in a variety of practical application, Manning's formula is valid for turbulent flow which is the most widely used uniform flow formula for designing storm water pipe conduits and channels. Due to its long practical use, values of n for a very wide range of surfaces are available as given in the Table 5.1. Charts for Manning's formula are given in Appendix A 5.5 (A) and Appendix A 5.5 (B) for the stated ranges of discharges.

While choosing the storm water pipe diameters, minimum required diameter is computed and the next larger commercial available pipe diameter is selected. In circular conduits, maximum velocity occurs at 0.81 depth and maximum discharge occurs at 0.95 depth.

Table 5.1: Coefficient of roughness for channel flow for use in manning's formula

Type of Material	Condition	Manning's n
Salt-glazed stoneware pipe	(a) Good	0.012
	(b) Fair	0.015
Cement concrete pipes (With collar joints)	(a) Good	0.013
	(b) Fair	0.015
*Spun concrete pipes (RCC & PSC) with S / S Joints (Design value)		0.011
Masonry	Neat Cement Plaster	0.018
	Sand and Cement Plaster	0.015
	Concrete, steel troweled	0.014
	Concrete, wood troweled	0.015
	Brick in good condition	0.015
	Brick in rough condition	0.017
	Masonry in bad condition	0.020
Stonework	Smooth, dressed ashlar	0.015
	Rubble set in cement	0.017
	Fine, well-packed gravel	0.020
Earth	Regular surface in good condition	0.020
	In ordinary condition	0.025
	With stones and weeds	0.030
	In poor condition	0.035
	Partially obstructed with debris or weeds	0.050
Steel	Welded	0.013
	Riveted	0.017
	Slightly tuberculated	0.020

Type of Material	Condition	Manning's n
	With spun cement mortar lining	0.011
Cast Iron / Ductile iron	Unlined	0.013
	With spun cement mortar lining	0.011
Asbestos Cement		0.011
Plastic (Smooth)		0.011
FRP		0.01
HDPE / UPVC		0.01

Note: Values of n may be taken as 0.015 for unlined metallic pipes and 0.011 for plastic and other smooth pipes

* n value for Spun concrete pipes (RCC & PSC) with S / S Joints may be taken as given by the manufacturer.

Source: *Manual on Sewerage and Sewage Treatment Systems*, by CPHEEO, 2013

5.3 Design consideration for storm water drains

Critical flow condition develops when Froude no equals to 1.0. In open channel flow design, critical state of flow should be avoided as under such condition the water surface becomes unstable and wavy. It is, therefore, recommended that the open channel flow should be designed so that the Froude no should not exceed 0.8 preferably and self-cleansing velocity as recommended in Table 5.2.

5.3.1 Permissible limit of Velocity

To ensure that deposition of suspended solids does not take place, self-cleansing velocities using Shield's formula is considered in the design of channels/conduits.

From findings of Shields, Camp derived the formula:

$$V = \frac{1}{n} * R^{\frac{1}{6}} [k_s (S_s - 1) d_p]^{(1/2)} \quad (5.9)$$

Where,

n : Manning's n

R : Hydraulic Mean Radius in m

k_s : Dimensionless constant with a value of about 0.04 to start motion of granular particles and 0.8 for adequate self-cleansing of conduits

S_s : Specific gravity of particles

d_p : Particle size in mm

Shields formula indicates that velocity required to transport material in conduits is only slightly dependent on conduit shape and depth of flow but mainly dependent on the particle size and specific weight. A velocity of 0.6 mps would be required to transport

sand particles of 0.09 mm with a specific gravity of 2.65 that are commonly found in storm water from urban catchments.

Table 5. 2: Design velocities to be ensured in gravity storm conduits/channels

S. No.	Criteria	Value
1	Minimum velocity	0.6 m/s
2	Maximum Velocity	3 m/s

Source: WPCF, ASCE, 1982

Note:

For hilly regions, maximum velocity to be permitted in storm water conduits should be 6.0 m/s for plastic pipes or other pipes lined with plastics.

5.3.2 Freeboard in open channel

The freeboard is the vertical distance from the water surface of designed flow condition to the top of the channel. The importance of this factor depends on the consequence of overflow of the channel bank. Freeboard should be sufficient to prevent waves, super elevation changes, or fluctuations in water surface from overflowing the sides. Recommended value of minimum freeboard for different width is as given in Table 5.3.

Table 5. 3: Minimum Free Board for open channels

	Drain Size	Free Board
(i)	Beyond 300 mm bed width	10 cm
(ii)	Beyond 300 mm & up to 900 mm bed width	15 cm
(iii)	Beyond 900 mm & up to 1500 mm bed width	30 cm

For larger drains, the freeboard shall be higher up to 90 cm depending upon the discharge. For storm conduits, freeboard is not defined as they are supposed to run full.

Source: IRC SP 50 – 2013

However, a steep gradient channel should have a freeboard height equal to the flow depth to compensate for the large variations in flow caused by waves, splashing, and surging.

5.3.3 Curves/bends in drains

Curves and bends are sometimes unavoidable in drain alignments. The complexity in the design arises due to increase in friction losses along the curve that causes serious local erosion due to spiral flow motion induced by the centrifugal force which is very pronounced and irregular in the bend.

Therefore, in order to reduce the super elevation of the water surface that occurs due to the difference in elevation of water surface between inside and outside wall of the bend at the same section and maintain the freeboard, a minimum radius of curvature of 3 times the width of the drain should be provided in the horizontal curve. Benching should be provided at the bend to minimize the sedimentation at the inner side of the bend.

5.3.4 Junction Sump for storm water drain intersection

A sump of sufficient size shall be provided where drains converge or intersect. The minimum internal width of the sump shall not be less than 2 times the width of the drain leading away from the sump. Drains shall enter the sump at angles less than a right angle and at different levels wherever possible. The invert level of the downstream drain shall be lower than the invert level of the sump so that no stagnant water will collect in the sump.

5.3.5 Hydraulically Efficient Channel Section

The conveyance of a channel section of a given area increases with a decrease in its perimeter. Hence a channel section having the minimum perimeter for a given area of flow provides the maximum value of the conveyance. With the slope, roughness coefficient and area of flow fixed, a minimum perimeter section will represent the hydraulically efficient section as it conveys the maximum discharge. This channel section is also called the best section. Proportions of some most efficient sections is given in Table 5.4.

Table 5.4: Proportions of Some Most Efficient Sections

Sl. No.	Channel Shape	Area (A_e)	Wetted Perimeter (P_e)	Width (B_e)	Hydraulic Radius (R_e)	Top width (T_e)	$\frac{Q \times n}{y_e^{8/3} S_0^{1/2}} = K_e$
1.	Rectangle (Half square)	$2Y_e^2$	$4Y_e$	$2Y_e$	$\frac{Y_e}{2}$	$2Y_e$	1.260
2.	Trapezoidal (Half regular)	$\sqrt{3}Y_e^2$	$2\sqrt{3} Y_e$	$\frac{2}{\sqrt{3}} Y_e$	$\frac{Y_e}{2}$	$\frac{4Y_{ec}}{\sqrt{3}}$	1.091

Sl. No.	Channel Shape	Area (A _e)	Wetted Perimeter (P _e)	Width (B _e)	Hydraulic Radius (R _e)	Top width (T _e)	$\frac{Q \times n}{y_e^{8/3} S_0^{1/2}} = K_e$
	hexagon, $m = \frac{1}{\sqrt{3}}$						
3.	Circular (semi-circular)	$\frac{\pi}{2} Y_e^2$	πY_e	$D = 2Y_e$	$\frac{Y_e}{2}$	$2Y_e$	0.9895
4.	Triangle (Vertex angle-90°)	Y_e^2	$2\sqrt{3} Y_e$	-	$\frac{Y_e}{2\sqrt{2}}$	$2Y_e$	0.500

Where,

n : Manning's Coefficient

e subscript : most efficient

Y_e : Depth of flow for the most efficient section in m

Q_n : Discharge in m³/sec

S_o : Bed slope

Source: Flow in open channels by K. Subramanaya

Example 5.1

Design the most efficient trapezoidal section for the following design parameters:

- Discharge (Q) = 20 m³/s
- Bed slope (S) = less than 0.0003
- Manning (n) = 0.013
- Depth of flow (Y) = Less than 3.0 m

Solution:

As per Table 5.4, conditions of most efficient Trapezoidal section:

$$\frac{Q \times n}{Y^{8/3} \times S^{1/2}} = 1.091$$

$$\text{So, } Y = \left(\frac{1.091 \times 0.013^{1/2}}{20 \times 0.0003} \right)^{3/8} = 2.88 \text{ m}$$

As, Y is less than 3.0 m; Hence, it is OK

As per Table 5.4, Hydraulic radius = $\frac{Y}{2}$

$$\text{Hydraulic radius} = \frac{2.88}{2} = 1.44 \text{ m}$$

As per Manning's formula, $v = 1/n \times R^{0.66} \times s^{0.5}$

$$v = \frac{1}{0.013} \times 1.44^{0.66} \times 0.0002^{0.5} = 1.387 \text{ m/s}$$

As per Table 5.4, v is greater than 0.6 m/s and less than 3 m/s. Hence, it is self-cleansing velocity and acceptable value of velocity.

Example 5.2

An open triangular channel of V-shaped with each side inclined at 45° to vertical. It carries a discharge of 40 LPS. When the depth of flow at the centre is 225 mm, calculate the slope of the channel.

Solution: Given Data

- Discharge (Q) = 40 LPS
- Manning's constant (n) = 0.013
- $\angle \theta = 45^\circ$
- Depth of flow (Y) = 0.225 m.

As per Table 5.4, condition for the best hydraulic section:

$$\frac{Qn}{Y^{8/3} \times S^{1/2}} = 0.5$$

$$\frac{0.04 \times 0.013}{0.225^{8/3} \times S^{1/2}} = 0.5$$

Solving the Equation: $S = 0.0030231$

Example 5.3

Find the most efficient section of the rectangular channel to carry 300 lps when the bed slope is 1 in 1000. (Given n as 0.013)

Solution:

Given data

- Discharge (Q) = 300 lps
- Bed slope is (S) 1:1000
- Manning Constant (n) = 0.013

As per Table 5.4, condition for most efficient rectangular channel:

$$\frac{Qn}{Y^{8/3} \times S^{1/2}} = 1.260$$

Solving the equation, $Y = 0.418$ m

As per the Table 5.4:

- Area of cross-section = $2Y^2 = 2 \times 0.418^2 = 0.349$ m²
- Width of channel = $2Y = 2 \times 0.418 = 0.836$ m
- Hydraulic radius, $R = Y/2 = 0.418/2 = 0.209$ m
- Velocity of flow is $(V) = 1/n \times R^{0.66} \times S^{0.5} = 1/0.013 \times 0.209^{0.66} \times 0.001^{0.5} = 0.865$ m/s

5.3.6 Partially Filled Circular Section

Area and hydraulic radius are static or elements of shape, and roughness, velocity and discharge are dynamic elements of flow. A partially filled circular section is shown in Figure 5.1. The basis for computation of both groups of elements are shown below:

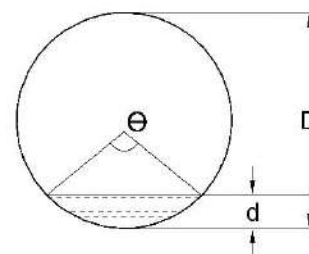

Figure 5. 1: Partially Filled Circular Section

$$\frac{a}{A} = \frac{\theta}{360^\circ} - \frac{\sin \theta}{2\pi} \quad (5.10)$$

$$\frac{r}{R} = 1 - \frac{360^\circ \sin \theta}{2\pi\theta} \quad (5.11)$$

$$\frac{v}{V} = \left(\frac{r}{R}\right)^{2/3}, \text{ where } n \text{ is Constant} \quad (5.12 - a)$$

$$\frac{v_s}{V} = \left(\frac{r}{R}\right)^{1/6}, \text{ where } n \text{ is constant} \quad (5.12 - b)$$

$$\frac{q}{Q} = \frac{a}{A} \left(\frac{r}{R}\right)^{2/3}, \text{ where } n \text{ is constant} \quad (5.13)$$

Where,

A : cross-section of the circular section

a : cross-section of the partially filled circular section

R : hydraulic radius of the full circular section

r : hydraulic radius of the partially filled section

V : velocity of flow of the full section

v : velocity of flow of the partially filled section

Q : discharge from full section flow

q : discharge from partially filled section

v_s : Self-cleansing velocity in partial flow circular conduits

From above equations, ratios of $\frac{d}{D}, \frac{v}{V}, \frac{a}{A}, \frac{q}{Q}$ can be calculated and tabulated as given Table 5.5 and graphical presentation in Figure 5.2. For self-cleansing velocity and change in slope, $\frac{v_s}{V}, \frac{Q_s}{Q_f}, \frac{S}{S_f}$ can be determined from the graphical presentation given in Figure 5.3.

Table 5. 5: Hydraulic Properties of circular sections for manning's formula

Constant (n)			Variable (n)		
d/D	v/V	q/Q	n_o/n	v/V	q/Q
1.0	1.000	1.000	1.00	1.000	1.000
0.9	1.124	1.066	1.07	1.056	1.020
0.8	1.140	0.968	1.14	1.003	0.890
0.7	1.120	0.838	1.18	0.952	0.712
0.6	1.072	0.671	1.21	0.890	0.557
0.5	1.000	0.500	1.24	0.810	0.405
0.4	0.902	0.337	1.27	0.713	0.266
0.3	0.776	0.196	1.28	0.605	0.153
0.2	0.615	0.088	1.27	0.486	0.070
0.1	0.401	0.021	1.22	0.329	0.017

Where,

D : Full Depth of Flow (Internal dia)

d : Actual Depth of Flow

V : Velocity at full depth

v : Velocity at depth 'd'

Q : Discharge at full depth

q : Discharge at depth 'd'

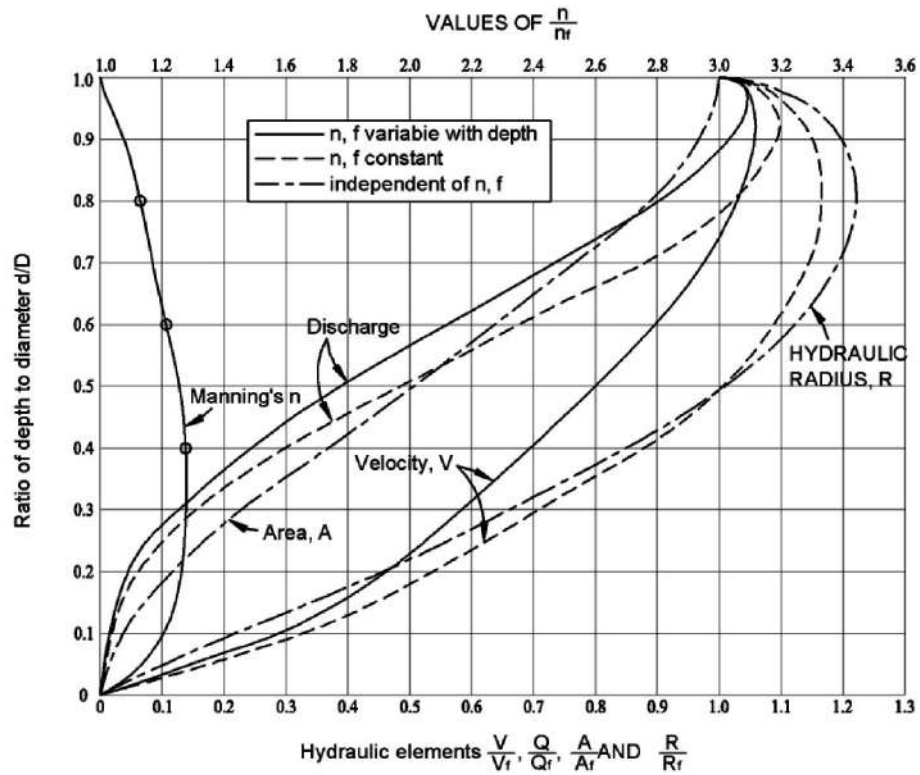

Figure 5. 2: Hydraulic – Element graph for circular storm water conduits

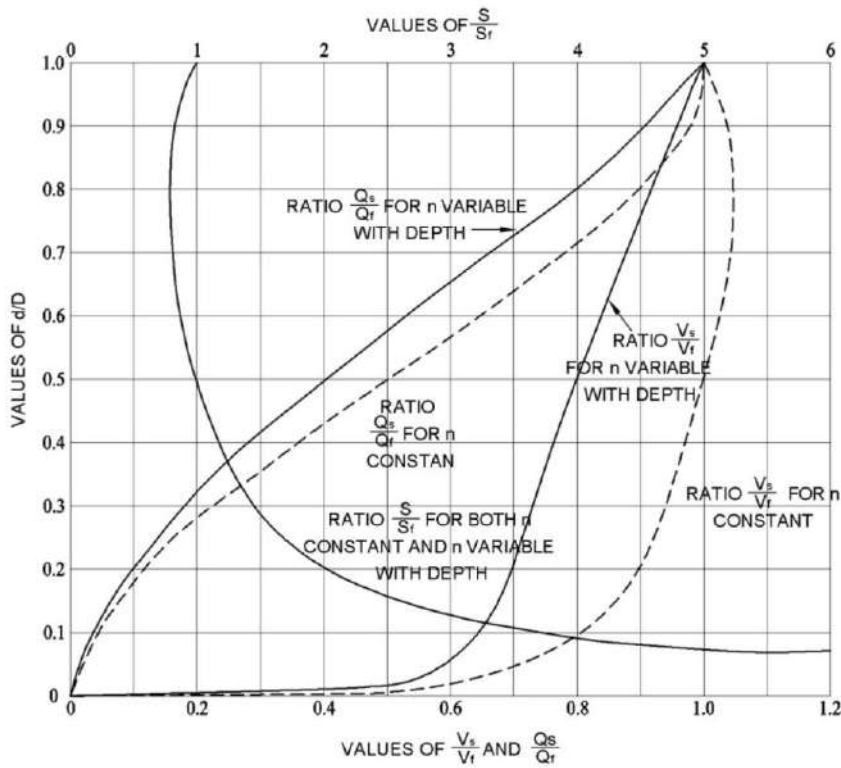

Figure 5. 3: Hydraulic elements of circular storm water conduits that possess equal self-cleansing properties at all depths

Example 5.4

A 225 mm dia storm water drain is to discharge of 0.005 cumecs at a required gradient of 1 in 1500. Find out the depth and velocity of flow in storm drain. Assume Manning's coefficient 'n' as 0.013.

Solution:

Using Manning's formula, discharge through the pipe while flowing full is given by;

$$Q = \frac{1}{n} A R^{2/3} \sqrt{S}$$

$$Q = \frac{1}{0.013} \cdot \frac{\pi}{4} (0.225)^2 \cdot \left(\frac{0.225}{4}\right)^{2/3} \cdot \sqrt{\frac{1}{1500}}$$

Hence, $Q = 0.0116 \text{ m}^3/\text{s}$,

$$\text{Now, } V = \frac{0.0116}{\frac{\pi}{4} \times (0.225)^2} = 0.292 \text{ m/s}$$

Discharge through the Drain when flowing partially full (q) = 0.005 cumec when

$$\frac{q}{Q} = \frac{0.005}{0.0116} = 0.431, \text{ then from above table, } \frac{d}{D} = 0.458, \quad \frac{v}{V} = 0.959$$

Depth & Velocity of partially filled drain,

$$\frac{d}{D} = 0.458, \quad d = 0.458 \cdot 0.225 = 0.103 \text{ m}$$

$$\frac{v}{V} = 0.959, \quad v = 0.959 \cdot 0.292 = 0.28 \text{ m/s}$$

5.4 Design Sheet

The designer should tabulate the complete hydraulic design of channels and conduits for the entire given network of project catchment area in the relevant columns given in Table 5.6 and Table 5.7.

Table 5. 6: Computation sheet for Storm Water Conduit

Drain ID		Drainage Area (Hec)		Ground Profile		time of concentration t_c (min)			Rainfall Intensity (mm /hr) (I)	Runoff Coeff. "C"	Runoff (Q)(m ³ /hr) 10CIA	Design								Profile					
From	To	Incremental Area	Total area	Slope of Ground Level (1 in)	Overland Flow Length (m)	Time of (t _o) inlet	Time of flow t _f	Total t _c = t _o + t _f				Manning Coefficient	Pipe Dia	Q _{Full}	Slope I in	Velocity mps		Length m	Time in Sec	Fall m	Drop in Manhole	Ground elevation		Invert Elevation	
1	2	3	4	5	6	7	8	9	10	11	12	13	14	15	16	17	18	19	20	21	22	23	24	25	26

Prepare a working plan layout and profile of the storm drainage system establishing the following design information:

Columns 1 to 2 identify the location of the drain, street, and manholes

Columns 3 to 4 record the increment in the tributary area and total area

Columns 5 to 6 gives the ground profile i.e. Slope and overland flow length

Columns 7 to 9 records the time of concentration from the formula given in Chapter 4 clause 4.4.1.6.

Column 10 is the value of the intensity of rainfall in mm corresponding to the time of concentration from IDF curve for required return period

Column 11 is the runoff coefficient from Table 4.2 given in Chapter 4

Column 12 is the value of runoff (CIA) in m^3/hr from each tributary area from the Rational formula given in Chapter 4.

Column 13 – 20 records the chosen size, required grade resulting capacity, full and actual velocity of flow for each drain or line. These designs of storm water conduit are computed from Manning's equation for each required flow and maintaining a self-cleansing velocity.

Column 21 – 26 identifies the profile of the drain

Column 21 is $\text{Column 19} \times \text{Column 16}$

Column 22 is the required drop in manholes is obtained directly from the recommended values in Chapter 11, section 11.3.7.5 Drop in Manhole.

Column 23 & 24 are upper and lower end Ground elevation

Column 25 & 26 gives invert elevation at the upper end with a minimum cover of 0.6 m at starting manhole. In case a manhole having more than one inlet, the drop in the manhole is considered with respect to the lowest invert level of the inlets to fix the invert level of the outlet.

Table 5.7: Computation sheet for Storm Water Open Channel

Drain ID		Drainage Area (Hec)		Ground Profile		time of concentration t_c (min)			Rainfall Intensity (mm/hr) (I)	Runoff Coeff. "C"	Runoff (Q)(m ³ /hr) 10CIA	Design										Profile			
From	To	Incremental Area	Total area	Slope of Ground Level (1 in)	Overland Flow Length (m)	Time of (t_o) inlet	Time of flow t_f	Total $t_c = t_o + t_f$				Manning Coefficient	Depth	Width	Q_{Full}	Slope I in	Velocity mps	Length m	Time in Sec	Fall m	Drop in Manhole	Ground elevation		Invert Elevation	
1	2	3	4	5	6	7	8	9	10	11	12	13	14	15	16	17	18	19	20	21	22	23	24	25	26

Prepare a working plan layout and profile of the storm drainage system establishing the following design information:

Columns 1 to 2 identify the location of the drain, street, and manholes

Columns 3 to 4 record the increment in the tributary area and total area

Columns 5 to 6 gives the ground profile, i.e. Slope and overland flow length

Columns 7 to 9 records the time of concentration from the formula given in Chapter 4 clause 4.4.1.6.

Column 10 is the value of the intensity of rainfall in mm corresponding to the time of concentration from IDF curve for required return period

Column 11 is the runoff coefficient from Table 4.2 given in Chapter 4

Column 12 is the value of runoff (CIA) in m^3/hr from each tributary area from the Rational formula given in Chapter 4.

Column 13 – 20 records the chosen size, required grade resulting capacity, velocity of flow for each drain or line. These designs of storm water open channel are computed from Manning's equation for each required flow and maintaining a self-cleansing velocity.

Column 21 – 26 identifies the profile of the drain

Column 21 is $\text{Column 19} \times \text{Column 17}$

Column 22 is the required drop in manholes is obtained directly from the recommended values in Chapter 11, section 11.3.7.5 Drop in Manhole'

Column 23 & 24 are upper and lower end Ground elevation

Column 25 & 26 gives invert elevation at the upper end with a minimum cover of 0.6 m at starting manhole. In case a manhole having more than one inlet, the drop in the manhole is considered with respect to the lowest invert level of the inlets to fix the invert level of the outlet.

A worked out example on design of storm water channels and conduits is given in Appendix 5.8.

5.5 Gutters and Inlets

5.5.1 Gutter

A pavement gutter is defined as a section of pavement adjacent to the roadway which conveys water during a storm runoff event. It may include a portion or all of a travel lane. Gutter sections usually have a triangular shape with the kerb forming the near-vertical leg of the triangle. Conventional gutters may have a straight cross slope or a composite cross slope where the gutter slope varies from the pavement cross slope.

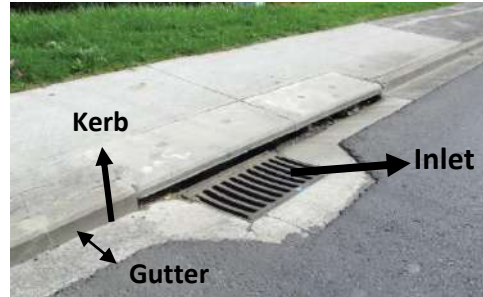

Figure 5. 4: Gutter and Inlet

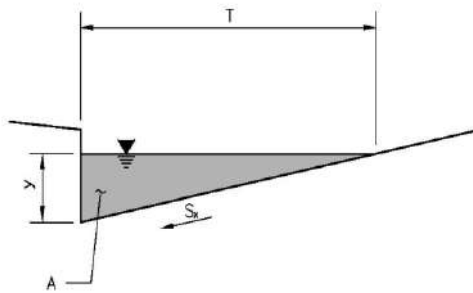

Figure 5.5: Gutter, section with uniform cross-slope

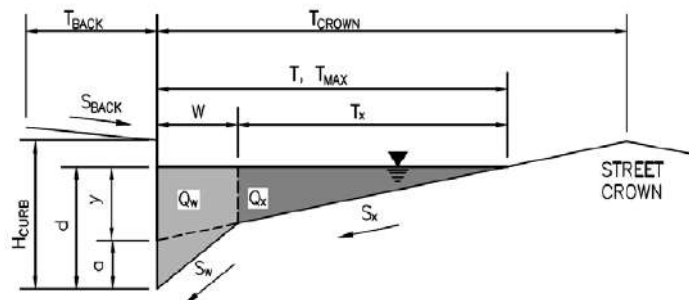

Figure 5.6: Typical gutter section—composite cross-slope

5.5.2 Design of Gutters

Gutter Flow calculations are necessary to establish the spread of water on the shoulder, parking lane, or pavement section. Streets with uniform cross slopes like that shown in Figure 5.4 are found in urban areas. Since the gutter flow is assumed to be uniform for design purposes, Manning’s equation is appropriate with a slight modification to account for the effects of a small hydraulic depth (A/T). However, for main roads and highways minimum gutter width should not be less than 0.6 m.

For a triangular cross-section as shown in Figure 5.5, Manning’s equation for gutter flow is written as:

$$Q = \frac{K_c}{n} S_x^{5/3} S_L^{1/2} T^{8/3} \tag{5.14}$$

Where,

K_c : Empirical constant equal to 0.376

n : Manning's roughness coefficient for gutter flow as given in Table 5.8

Q : Flow rate (m^3/s)

T : Width of flow (spread), m

S_x : Cross slope, m/m

S_L : Longitudinal slope, m/m

Equation neglects the resistance of the kerb face since this resistance is negligible.

The flow depth (m) can be found using:

$$Y = TS_x \quad (5.15)$$

And,

$$\text{The cross-sectional flow area, } A = \frac{S_x T^2}{2} \quad (5.16)$$

Table 5. 8: Manning's n for gutter flow

Surface type	n
Concrete	0.013
Hot mix asphaltic concrete	0.015
Sprayed seal	0.018

Example 5.5

A triangular gutter of concrete has a longitudinal slope of 1%, cross slope of 2%, and a kerb depth of 0.2 m. Determine the flow rate and flow depth if the spread is limited to 2 m.

Solution:

$$Q = \frac{K_c}{n} S_x^{5/3} S_L^{1/2} T^{8/3}$$

Where,

K_c = empirical constant = 0.376

n : Manning's roughness coefficient = 0.012

Q : Flow rate (m^3/s)

T : Width of flow (spread) = 2 m

S_x : Cross slope = 0.02

S_L : Longitudinal slope = 0.01

$$Q = \frac{0.376}{0.012} \times 0.02^{5/3} \times 0.01^{1/2} \times 2^{8/3} = 31.33 \times 0.00145 \times 0.1 \times 6.364 = 0.029 \text{ m}^3/\text{s}$$

5.5.3 Composite Gutter Sections

The design of composite gutter sections requires consideration of flow in the depressed segment of the gutter, Q_w . Equations are provided for use to determine the flow in a width of gutter in a composite cross-section, W , less than the total spread, T . For a composite street section as given in Figure 5.6:

$$Q = Q_w + Q_x \quad (5.17)$$

Q_w : Flow rate in the depressed section of the gutter (m^3/s) (flow within gutter width, W)

Q_x : Flow capacity of the gutter section above the depressed section and within the street width, T_x , (m^3/s)

$$Q = \frac{Q_x}{(1 - E_0)} \quad (5.18)$$

Where,

$$E_0 = \frac{1}{1 + \frac{S_w / S_x}{\left[1 + \frac{S_w / S_x}{(T/W) - 1}\right]^{8/3}} - 1} \quad (5.19)$$

And,

$$S_w = S_x + a/W \quad (5.20)$$

Where,

Q : Gutter flow rate (m^3/s)

E_0 : Ratio of flow in a chosen width (usually the width of a grate) to total gutter flow (Q_w/Q)

W : width of the gutter (typical value = 0.6 m)

S_w : the gutter cross slope (typical value = 1/12)

a : gutter depression = $WS_w - WS_x$

Figure 5.6 depicts all geometric variables. From the geometry, it can be shown that:

$$Y = a + TS_x \quad (5.21)$$

And,

$$A = \frac{S_x T^2 + aW}{2} \quad (5.22)$$

Where,

Y : Flow depth above the depressed gutter section (m). Note that the depth of flow at the gutter line is defined as d, where $d = Y + a$

A : flow area (m²)

Example 5.6

Determine the discharge in a composite gutter section if the allowable spread is 3 m, the gutter width is 0.6 m, and the vertical depth between gutter lip and gutter is 0.05 m. The street's longitudinal slope is 1%, the cross slope is 2%, and the kerb height is 0.2 m.

Solution:

First determine the gutter cross slope, S_w , using Equation 5.20:

$$S_w = S_x + \frac{a}{W}$$

$$S_w = 0.02 + \frac{\left(\frac{0.6}{12} - 0.6 \times 0.02\right)}{0.6} = 0.083 \text{ m}$$

The flow in the street is found as:

$$Q_x = \frac{K_c}{\eta} S_x^{5/3} S_L^{1/2} T_x^{8/3}$$

$$Q_x = \frac{0.376}{0.012} 0.02^{5/3} 0.01^{1/2} 2.4^{8/3} = 0.047$$

$$E_0 = \frac{1}{\left\{ 1 + \frac{0.083/0.02}{\left[1 + \frac{0.083/0.02}{\frac{3.6}{0.6} - 1} \right]^{2.67}} - 1 \right\}} = 0.4920$$

Now the theoretical flow rate can be found as:

$$Q = \frac{Q_x}{(1 - E_0)} = \frac{0.047}{(1 - 0.492)} = 0.0925$$

Then, the computed flow depth is:

$$Y = a + TS_x = 0.036 + 3.6 \times 0.02 = 0.108 \text{ m}$$

5.6 Storm water inlets

Storm water inlets are devices used to collect runoff and discharge it to an underground storm drainage system. Inlets are suitably located on pavements, in gutter sections, paved medians, roadside and at locations of specific requirement.

5.6.1 Types of inlets

i. Grate inlets

Grate inlets are horizontal openings covered with one or more suitable gratings through which the flow passes.

ii. Kerb inlet

Kerb inlets are vertical openings in the road kerb when they are equipped with the diagonal notches cast into the gutter along the kerb opening to form a series of ridges or deflectors. Such inlets are suitable where heavy traffic is expected.

iii. Combination inlets

Combined grate and kerb inlets are more efficient. These are compound of a kerb and gutter inlet acting as a single inlet. Following figures 5.7 and 5.8 give the details of different types of the inlet, as shown below:

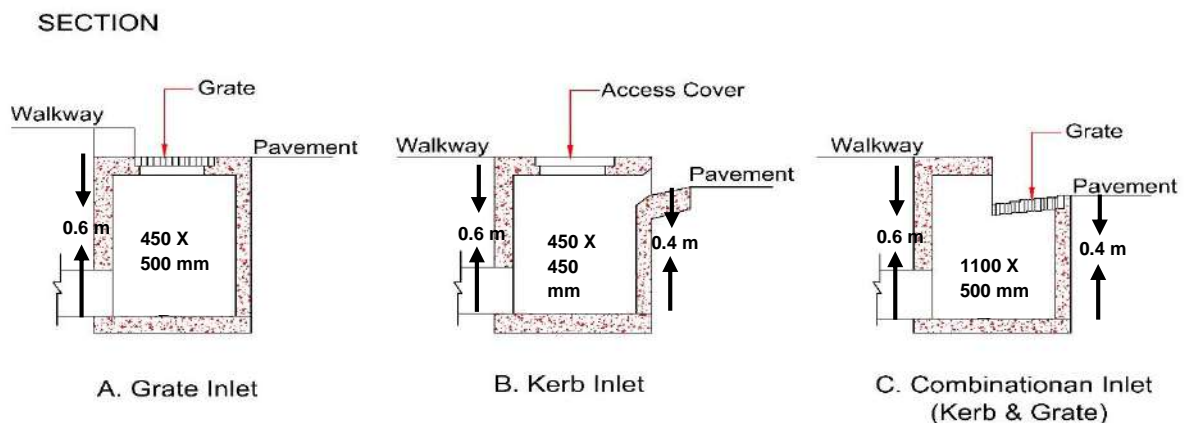

Figure 5. 7: Section of Street Inlet

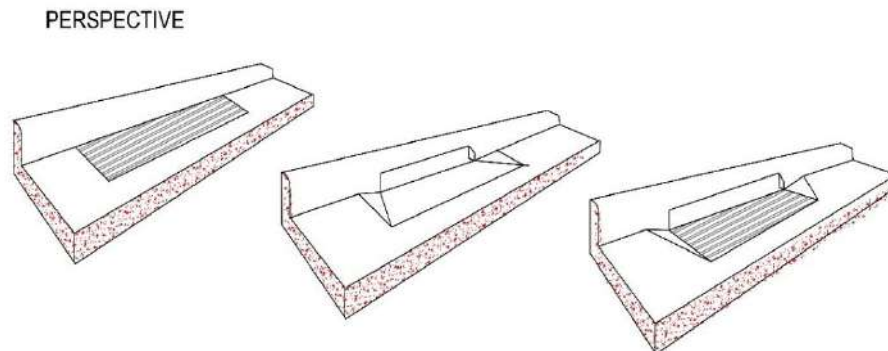

Figure 5. 8: Plan of street inlet

iv. Catch basin

The catch basin illustrated in Fig 5.9 is a special type of inlet structure designed to retain sediment and debris transported by storm water which might enter into storm water system and clog the storm pipes.

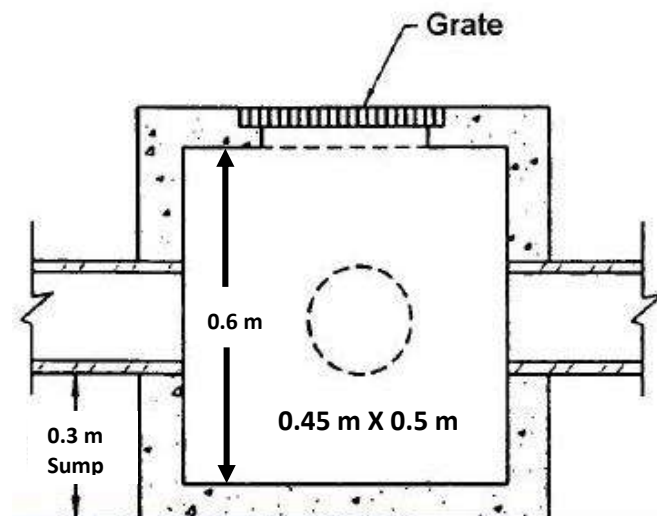

Figure 5. 9: Catch Basin

A separate catch basin may be used for each or at alternate of every 3 street inlet to further save expenses, the pipes from several outlets at a corner may discharge into the same catch basin. Catch basin sumps require periodic cleaning to be effective and if not properly maintained, they may become odorous and mosquito nuisance.

5.6.2 Design of Inlets

Inlets admit storm runoff to storm water drains. They are designed to remove the flow in gutters with minimum interference to traffic. There are 3 general types of inlets Kerb Inlets, Gutter Inlets, and Combination Inlets.

On the basis of model studies, empirical formulae are developed for flow into gutter inlets and kerb inlets with and without depression as follows:

$$\frac{Q}{L} = 0.04176 \times d^{0.5} \quad (5.23)$$

$$\frac{Q}{L} = 1.296 \times i^{0.579} \times \left(\frac{Q_o}{\sqrt{S}/n} \right)^{0.563} \quad (5.24)$$

Where,

Q_o : Discharge into the inlet, m³/sec

Q : Flow in Gutter, m³/sec

L : Length of the opening, m

i : Cross slope of the gutter

S : Longitudinal slope

d : Depth of flow in Gutter, m

Example 5.7

For a flow of 0.0283 m³/sec, a longitudinal street grade of 2 %, a mean crosswise street grade of 5.6% and a manning coefficient of 0.015, find (a) length of an undepressed kerb inlet required to capture 90% of flow, and (b) maximum depth of flow in gutter

Solution:

$$\frac{Q}{L} = 1.296 \times i^{0.579} \times \left(\frac{Q_o}{\sqrt{S}/n} \right)^{0.563}$$

$$\frac{Q}{L} = 1.296 \times 0.056^{0.579} \times \left(\frac{0.0283}{\sqrt{0.02}/0.015} \right)^{0.563} = 0.00928$$

For 90% capturing

$$\frac{0.9 \times 0.0283}{L} = 0.00928$$

Hence, $L = 2.74$

Calculate depth:

$$\frac{Q}{L} = 0.04176 \times d^{0.5}$$

$$\frac{0.0283}{2.74} = 0.04176 \times d^{0.5}$$

$$d = 0.06 \text{ m}$$

The kerb Inlet is designed for length 2.74 m, and depth of flow in the gutter at the kerb Inlet is 0.06 m.

5.6.3 Location of inlets

Inlet structures are located at the upstream end and at intermediate points along the gutter line. Inlet spacing is controlled by the geometry of the site, inlet opening capacity, and tributary drainage magnitude. Inlet placement is generally a trial and error procedure that attempts to produce the most economical and hydraulically effective system.

Following rules may be observed while locating storm water inlets:

- Inlets are constructed from the uppermost point of the gutter section, successively spaced by locating the point where, some of the bypassing flow and the flow from the additional contributing area, exceed the gutter capacity.
- The inlet should be placed at intersections to prevent street cross-flow, which could cause pedestrian and vehicular traffic hazards.
- Inlets are also required where the street cross slope begins to super elevate.
- The inlet should be located at any point where side drainage enters streets and may overload gutter capacity
- Inlets are required to be constructed at all low points in the gutter grade and at median breaks.
- Inlets should be located upstream of the bridges to prevent storm flow on to the bridge deck and down stream of bridges to intercept drainage from the bridge.

- As a matter of general practice, inlets should not be placed within driveway areas.
- Minimum spacing should not be less than 10 m and the maximum should not be greater than 30 m.

Example 5.8

Determine inlet spacing to cater runoff from half road catchment. Following data are given:

- Rainfall intensity for Design storm, $I = 300$ mm/hr
- Half road width = 9 m
- Longitudinal slope = 0.5 %
- Cross slope = 3%
- Width of gutter = 1.5 m
- Runoff coefficient = 0.91

Solution:

- Runoff as per Rational formula (Q_{road}) = $CIA/360$
 $= 0.91 \times 300 \times (9 \times L_1 \times 10^{-4})/360$
 $= 0.000683 L_1$

Where L_1 is the length of gutter flow in the upstream sub-catchment.

- Calculate the allowable limit of gutter flow.

Compute the gutter discharge, Q , using the equation

$$Q = \frac{K_c}{n} S_x^{5/3} S_L^{1/2} T^{8/3}$$

Where:

K_c = empirical constant equal to 0.376

n = Manning's roughness coefficient = 0.013

T = Width of flow (spread) = 1.5 m

S_x = Cross slope = 0.003

S_L = Longitudinal slope = 0.005

Using $W = 1.5$ m;

$$Q = 0.018 \text{ m}^3/\text{s}$$

= 18 L/s and $V \times D$ is less than 0.4 m/s.

Therefore, spacing for the first inlet is,

$$L_1 = 0.018 / 0.000683$$

$$= 26.3 \text{ m} \gg 26 \text{ m}$$

Therefore, the inlet spacing to be adapted is 26 m.

5.7 Gradually Varied Non-uniform Flow

If subcritical flow exists in a channel of mild slope and this channel meets with a channel of a steep slope in which the flow is supercritical, then there will be the change of surface level between the two. In this situation the water surface level changes gradually between the two. The flow in the joining region is known as gradually varied flow. And if the situation is reversed that is upstream slope is steep with a supercritical flow and downstream with a subcritical flow, then there must occur a hydraulic jump to join the two. There may occur a short length of gradually varied flow between the channel junction and the jump. The above situations are shown in figure 5.10.

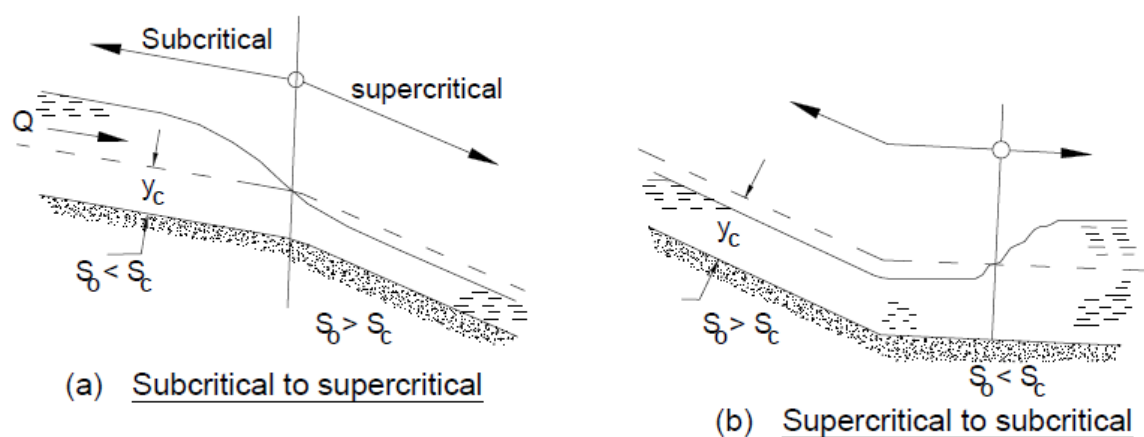

Figure 5.10: Examples of Subcritical & Supercritical Flow

Similarly if a storm channel discharges in a river/ stream, two situations may arise (1) when river/stream surface level is below the invert of discharging channel (2) when surface level of stream/ river is above the invert of the storm channel and above the surface level of water in the channel.

In the first case, a Draw down curve type of profile develops with gradually varied flow originating from the point of drop backward. In the second case, a backwater curve

develops, and the profile can be determined from analysis. Channels/ conduits should be designed considering water profiles under these conditions.

5.7.1 Basic equation for gradually varied flow

The basic assumption in the derivation of gradually varied flow is that the change in energy with distance is equal to the frictional losses. Based on the above assumption, the gradually varied flow equation can be given as follows:

$$\frac{dY}{dX} = \frac{S_o - S_f}{1 - F_r^2} \quad (5.25)$$

Where,

F_r : Froude Number

Y : Depth of flow

X : Distance along flow alignment

S_o : Bed slope

S_f : Friction Slope

The basic equation of gradually varied flow describes variation of depth Y with distance X in terms of the bed slope. So, also the friction slope, S_f , the discharge Q and channel shape.

The differential equation of gradually varied flow as derived above has no explicit solution except numerical integration method, which is the only practical solution.

5.7.2 Method of solution of the gradually varied flow equation

There are two basic numerical methods that are used to solve the above flow equations:

1. Direct Step Method – Distance from depth
2. Standard Step Method – Depth from distance

5.7.2.1 Direct Step Method

This method is the simplest and is suitable for use in prismatic channels and conduits. The equation used is:

$$\Delta E_s = \Delta X(S_o - S_f) \quad (5.26)$$

Following steps may be followed:

- Assume the value of control depth
- Calculate the specific energy E_{sg}
- Calculate S_f (mean)
- Calculate ΔE_s and calculate corresponding ΔX which is the distance from the starting point and subsequently between intervals

Example 5.9

A 3.0 m diameter circular outfall storm conduit laid on a gradient of 1 in 2000 discharges 5.0 m³/sec in a tidal river. During tidal hours the water level of the river rises 2.0 m above the invert of the incoming conduit whereas during non-tidal hours the water level of the river recedes below 1.5 m below the invert of the incoming conduit. Determine water surface profile generated inside the conduit during tidal and non-tidal hours. Assume $n = 0.013$

Solution (i) for Back water curve:

Discharge = 5.0 m³/sec

Diameter = 3.0 m

Slope = 0.0005

By applying formula $Q = A^{5/3} s^{1/2} / n * P^{2/3}$

At full flow discharge = 10.0 m³/sec approximately

Calculate the depth of flow at 5 m³/sec discharge.

$$As, \frac{q}{Q} = 0.5$$

So, from Table 5.5, $\frac{d}{D} = 0.5$

$$d = 0.5 \times 3 = 1.5 \text{ m}$$

During tidal hours the river water rises 2.0 m above the invert of the conduit which will create a back water curve of surface level of water inside the conduit. To plot the profile of back water curve, computations are given in the following table along with corresponding plot of back water profile under gradually varied flow condition. Obtain depth, area, hydraulic radius from given table of geometric element for circular channel section given in Appendix 5.3 and for trapezoidal section is given in Appendix 5.4.

Table 5. 9: Calculation of back water curve

S. No.	Bed Slope (S _o)	Manning Coefficient (n)	Discharge	Depth	Flow Area	Hydraulic mean radius (R)	Velocity	Specific Energy (E _s)	Frictional slope (S _f) (mean)	S _o -S _f	ΔE _s	Cumulative Distance(X)
			m ³ /s	m	m ²	m	m/s	(m)	(m)	(m)	(m)	(m)
	1	2	3	4	5	6	7	8	9	10	11	12
1	0.0005	0.013	5	2	4.95	0.8697	1.0103	2.0520222	0.000208	0.000292	0	0
2	0.0005	0.013	5	1.9	4.69	0.8517	1.0659	1.9579091	0.000223	0.000277	0.0941130	339.53
3	0.0005	0.013	5	1.8	4.43	0.8328	1.1292	1.8649869	0.000249	0.000251	0.0929223	709.61
4	0.0005	0.013	5	1.7	4.07	0.8028	1.2275	1.7767939	0.000295	0.000205	0.0881930	1140.02
5	0.0005	0.013	5	1.6	3.8	0.7773	1.3143	1.6880423	0.000352	0.000148	0.0887516	1738.80
6	0.0005	0.013	5	1.5	3.53	0.7500	1.4147	1.6020080	0.000424	0.000076	0.0860343	2871.96

Calculation shall be done as follows:

- i. Column 1 records Bed slope (S_o) of the conduit
- ii. Column 2 records Manning's coefficient (n)
- iii. Column 3 records discharge
- iv. Column 4 records the control depth which is the water level of river above the invert level of the conduit, 2.0 m. Step ΔY is taken as 0.1.
- v. Column 5 records flow area which can be obtained from the Table given in Appendix 5.3: Geometric elements for Circular Channel Sections
- vi. Example: As, $y/d_o = 2/3 = 0.67$ for control depth 2 m
- vii. From Table given in Appendix 5.3: $A/d_o^2 = 0.5594$
- viii. So, $A = 0.5594 \times 32 = 5.0346 \text{ m}^2$
- ix. Column 6 records Hydraulic mean radius which can be obtained from the Table given in Appendix 5.3: Geometric elements for Circular Channel Sections
- x. Example: As, $y/d_o = 2/3 = 0.67$ for control depth 2 m
- xi. From Table given in Appendix 5.3: $R/d_o = 0.2917$
- xii. So, $R = 0.2917 \times 3 = 0.8751 \text{ m}$
- xiii. Column 7 records Velocity = Discharge / Flow area
- xiv. Column 8 records Specific energy = $Y + v^2/2g$
- xv. Column 9 records S_f which is calculated from Manning's formula. $S_f = (v \times n / R^{2/3})^2$
- xvi. Column 10 records S_o - S_f (mean)
- xvii. Column 11 records change in specific energy with respect to change in depth of water

xviii. Column 12 records cumulative distance calculated from the formula

$$\Delta E_s = \Delta X(S_o - S_f)$$

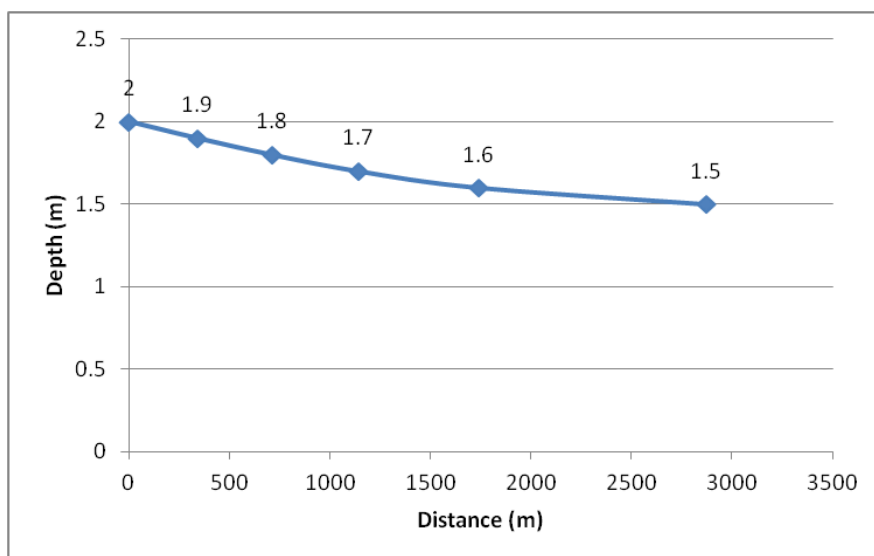

Figure 5. 11: Depth Distance Relationship (Back Water Curve)

Solution (ii) for Draw down curve:

When river water during non-tidal hours recedes 1.5 m below invert level of incoming conduit, the storm water discharging in the river falls freely, consequently creating a draw down curve starting from the outfall point in the conduit backward till it attains normal depth. Computations for draw down curve along with graph of draw down curve profile based on the theory and analysis of gradually varied flow conditions in open channel as given in the manual.

For finding the critical depth and other geometric elements from the table given in Appendix A 5.3 containing the geometric elements of the circular channel section.

$$Z \text{ (section factor)} = Q/g^{1/2} = 5/9.8^{1/2} = 1.596$$

$$Z/d_o^{2.5} = 1.596/15.58 = 0.10, \text{ for this } y/d_o = 0.318$$

Hence y (critical depth) = 0.95 m, this is the control depth for computation as given below

Table 5. 10: Calculation of draw down curve

S. No.	Bed Slope (S_o)	Manning Coefficient (n)	Discharge	Depth	Flow Area	Hydraulic mean radius (R)	Velocity	Specific Energy (E_s)	Frictional slope (S_f) (mean)	$S_o - S_f$	ΔE_s	Cumulative Distance(X)
			m^3/s	m	m^2	m	m/s	(m)	(m)	(m)	(m)	(m)
	1	2	3	4	5	6	7	8	9	10	11	12
1	0.0005	0.013	5	0.95	1.867	0.527	2.6787	1.3157114	0.0028523	-0.002352	0	0
2	0.0005	0.013	5	1.1	2.291	0.593	2.1821	1.3426829	0.0022330	-0.001733	-0.0269715	15.56
3	0.0005	0.013	5	1.2	2.641	0.643	1.8935	1.3827409	0.0016629	-0.001163	-0.0400580	50.01
4	0.0005	0.013	5	1.3	2.906	0.677	1.7205	1.4508759	0.0012521	-0.000752	-0.0681350	140.60
5	0.0005	0.013	5	1.4	3.174	0.710	1.5752	1.5264576	0.0009572	-0.000457	-0.0755817	305.92
6	0.0005	0.013	5	1.5	3.534	0.750	1.4147	1.6020080	0.0007268	-0.000227	-0.0755504	639.07

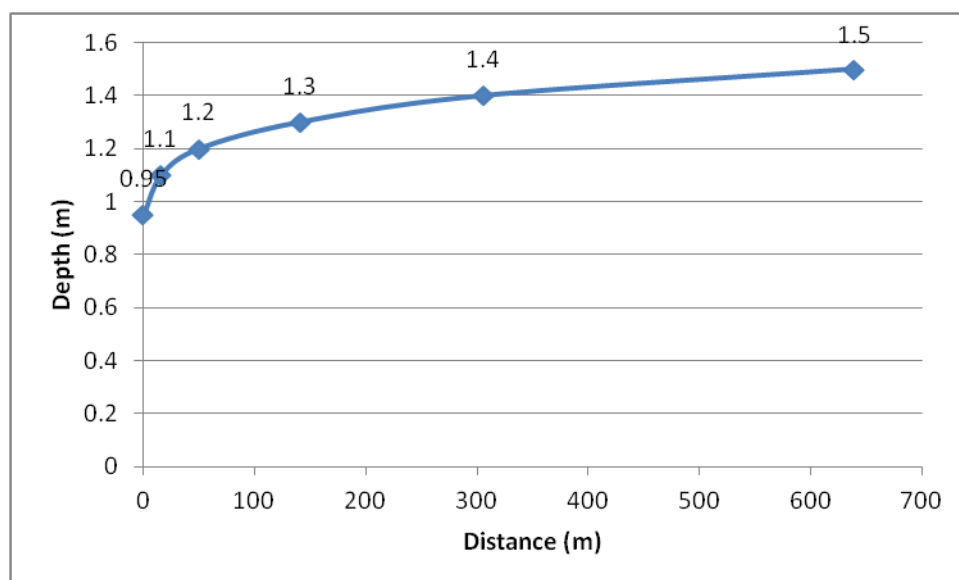

Figure 5. 12: Depth Distance Relationship (Draw Down Curve)

5.7.2.2 Standard Step Method

The Standard Step Method, on the other hand, is tedious iterative and is usually applicable to non-prismatic channels like rivers and streams.

5.8 Rapidly Varied Non – Uniform Flow

Rapidly varied non-uniform flow produces abrupt changes in depth and velocity over very short distances, as in the case of flow over spillway, over the sharp-crested weir and flow through regions of changing cross-sections. Rapid change can also occur when there is a change from supercritical to subcritical flow in a channel reach at a hydraulic jump as shown in figure 5.13.

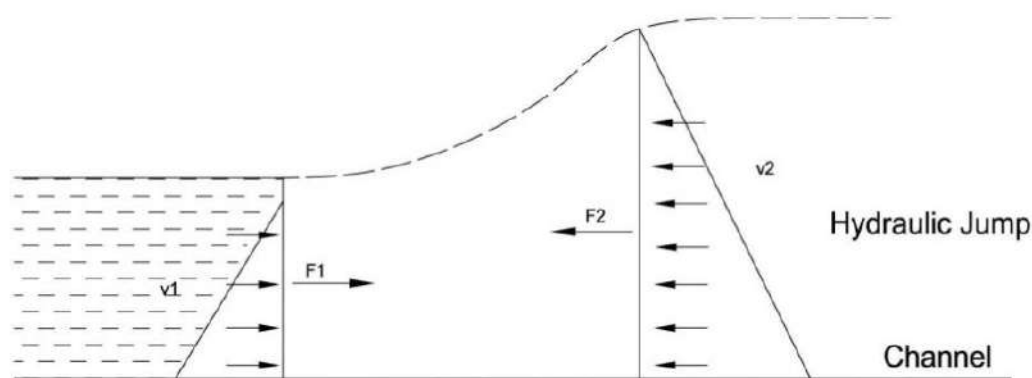

Figure 5.13: Hydraulic Jump

Following equation can be used to compute depth of hydraulic jump when incoming flow depth, velocity and channel geometry are given:

$$Y_2 = \frac{Y_1}{2} \left[\sqrt{8F_r^2 + 1} + 1 \right] \quad (5.27)$$

Froude number can be determined by the formula given under specific energy section.

5.8.1 Energy Dissipation

Storm pipe drains constructed in plains are commonly designed for subcritical flow, developing a self-cleansing velocity that may not cause erosion in channel/pipe or damage hydraulic structures. But in hilly region high velocity of moving storm water down the steep slope causing supercritical flow conditions cannot be avoided, and that may result in rapid erosion of channel and damage to the downstream structures. To safeguard against such risks two control measures are generally adopted either to reduce the velocity of flow or dissipate the energy by means of hydraulic jump as described.

5.8.2.1 Stepped Channel

Stepped channels are commonly employed to permit flow along the slopes. They can effectively dissipate the energy and reduce the velocity within safe limits. Design guidelines for such channels may be referred to Appendix A 5.2.

5.8.2.2 Chute

Chutes are constructed to dissipate the energy down the slope where it flattens to gentle slope, resulting in the hydraulic jump. This reduces the velocity of flow on the paved apron to a point where the flow becomes incapable of scouring the down-stream

channel bed. The jump is confined to the channel reach that is known as the stilling basin. In practice the stilling basin is seldom designed to confine the entire length of free hydraulic jump on the paved apron because such a basin would be too expensive. Consequently accessories such as sill etc. to control the jump are usually installed in the basin. The main function of such control is to shorten the range within which the jump will take place. The control improves the dissipation of energy function of the basin and stabilises the jump action. Design guidelines may be referred to any standard book on irrigation and hydraulic structures Like Irrigation Engineering and Hydraulic Structures.

5.8.2.3 Aprons

Aprons are provided upstream and downstream of the weir in order to protect the scour from reaching to the concrete floor upstream and downstream of the weir.

5.8.2.4 Afflux

The rise in the maximum flood level (HFL) upstream of the weir caused due to the construction of weir is called Afflux. This may occur in storm channels if control structure or obstruction is placed across the channel that extends as backward curve discussed in Gradually Varied Flow phenomenon.

5.8.2.5 Loss of Energy in Hydraulic Jump

Loss of energy in hydraulic jump is calculated from the following formula:

$$E_s \text{ (Energy Loss)} = (Y_2 - Y_1)^3 / 4Y_1Y_2 \quad (5.28)$$

Where,

Y_1 : Depth of flow before jump

Y_2 : Depth of flow after jump

An example on critical depth and specific energy is given in Appendix A 5.1.

Example 5.10

A concrete chute with a stream width of 0.6 m is discharging water down the embankment of 3.0 m height with a steep slope. The discharge is $0.1 \text{ m}^3/\text{s}$. Find the velocity and depth of water down the slope of the toe level where hydraulic jump takes place. Find also the energy dissipated due to jump.

Since the water is to move down the steep slope, critical depth at critical velocity will be developed at the edge of the fall.

Solution:

$$Q = 0.1 \text{ m}^3/\text{s}$$

$$B = 0.6 \text{ m.}$$

$$A_c = B \times Y_c = 0.6 Y_c$$

Y_c = Critical depth

V_c = Critical velocity.

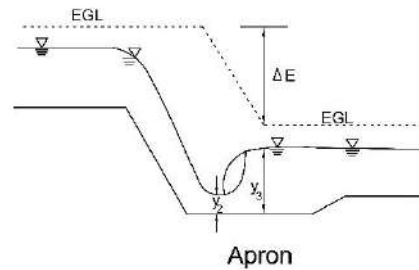

As per the following formula, at a critical depth

$$\frac{Q^2 B}{g A_c^3} = 1$$

Solving the equation,

Y_c is obtained as 0.14 m and $V_c = 1.190 \text{ m/s}$

$$E_s = Y_c + \frac{V_c^2}{2g} = 0.14 + \frac{(1.190)^2}{2 \times 9.81} = 0.212 \text{ m}$$

After 3.0 m drop, energy level at the toe level is equal to $3 + 0.212 = 3.212 \text{ m}$

$$Y_2 + \frac{V_2^2}{2g} = 3.212 \text{ m}$$

$$Q / 0.6 = V_2 \times Y_2$$

$$0.1/0.6 = 0.167 = V_2 \times Y_2$$

$$V_2 = 0.167 / Y_2$$

$$3.212 = Y_2 + \frac{\left(\frac{0.167}{Y_2}\right)^2}{2g}$$

$$Y_2 = 0.021$$

$$V_2 = 7.9 \text{ m/s}$$

Froude Number is calculated by the formula:

$$F_r = \frac{v}{\sqrt{gy}} = \frac{7.9}{0.453} = 17$$

$$Y_2 = 0.021$$

$$Y_3 = \frac{Y_2}{2} \left\{ \sqrt{8Fr^2 + 1} - 1 \right\}$$

$$= \frac{0.021}{2} \times \left\{ \sqrt{8 \times 17^2 + 1} - 1 \right\}$$

$$= \frac{0.021}{2} \times 47.09 = 0.49 \text{ m}$$

$$V_3 = 0.1 / (0.6 \times 0.49) = 0.34 \text{ m/s.}$$

$$\begin{aligned} \text{Loss of energy} &= (Y_3 - Y_2)^3 / 4 Y_2 Y_3 \\ &= 2.51 \text{ m} \end{aligned}$$

5.9 Hydraulic routing

The flow of storm water through channel and conduit occurs in the state of unsteady condition and its flow rate, velocity and depth vary in space and time throughout the channel/ conduit system. To obtain the values of these parameters hydraulic flow routing based on partial differential equations known as saint venant equations for one-dimensional flow can be applied. The following contains the summary of these equations neglecting lateral inflow.

Continuity and Momentum Equations

Continuity equation

Conservation form
$$\frac{\partial Q}{\partial x} + \frac{\partial A}{\partial t} = 0$$

Nonconservation form
$$V \frac{\partial y}{\partial x} + y \frac{\partial V}{\partial x} + \frac{\partial y}{\partial t} = 0$$

Momentum equation

Conservation form

$$\frac{1}{A} \frac{\partial Q}{\partial t} + \frac{1}{A} \frac{\partial}{\partial x} \left(\frac{Q^2}{A} \right) + g \frac{\partial y}{\partial x} - g(S_o - S_f) = 0$$

Local acceleration term	Convective acceleration term	Pressure force term	Gravity force term	Friction force term
-------------------------------	------------------------------------	---------------------------	--------------------------	---------------------------

Nonconservation form (unit width element)

$$\frac{\partial V}{\partial t} + V \frac{\partial V}{\partial x} + g \frac{\partial y}{\partial x} - g(S_o - S_f) = 0$$

_____ Kinematic wave
 _____ Diffusion wave
 _____ Dynamic wave

As shown above, alternative hydraulic flow routing equations are formulated by using full continuity equation while eliminating some terms of momentum equation. The simplest hydraulic routing equation is the kinematic wave that includes the gravity and frictional forces only, balancing each other while neglecting other terms. The diffusion wave routing equation incorporates the pressure term only. The dynamic wave equation considers all the terms of the momentum equation.

Hydrograph generated by rainfall-runoff simulation as described in chapter 4 is routed by these equations as per requirement of the flow condition through channels/ conduits to the outfall point. The channel/conduit can be sized from resulting computations of flow rate, velocity, and depth along any section of the channel/ conduit. The resulting hydrograph can also be generated at the outfall end.

Storm Water Management Model 'SWMM' developed by US EPA is a computer software program that is widely used to successfully perform the related computations.

Hydraulic modeling has become increasingly acceptable solutions in planning and design of urban storm drainage systems since these solutions are more sustainable help in designing the system without complicated and time consuming manual computations compared to traditional practices. SWMM model description and case study is given in Appendix A 5.9.

5.10 Engineered Channels

The storm drainage system should be designed in an environmentally responsible manner to minimize disruption of the natural environment of the city natural streams/waterways. Engineered waterways/channels are preferred means of meeting the objective by providing a drainage system that more closely resembles natural streams/waterways. These channels are components of the major drainage system designed to collect and convey flows from minor drainage system. The following sections discuss the design guidelines for engineered channels as well as modified natural channels.



Figure 5. 14: Concrete Channel



Figure 5. 15: Natural Channel

Design guidelines for engineered channels are given in Table 5.11.

Table 5. 11: Design Guidelines for Engineered Channels

S. No.	Item	Value
1.	Design Flows	25 years Return Period (as per the past historical data)
2.	Flow Regime	Froude number < 0.8
3.	Design velocity with grassed lining- With other lining such as- <ul style="list-style-type: none"> • Riprap • Concrete 	1.2 m/sec maximum 1.8 m/sec 3.0 m/sec
4.	Maximum Longitudinal Slope	0.4 % for natural lining 0.2 % for concrete lining
5.	For steep slope	Drop structure may be provided
6.	For curvature into the channel	Centreline of curvature should have minimum radius, 2x top width, but not less than 30 m

Note: Natural channels should be preserved as far as possible, and engineering of channels should be minimized.

5.10.1 Curvature and Super Elevation

Superelevation should be provided on outside bend of channel as per the following equation:

$$\Delta y = \frac{v^2 T}{2gr_c} \quad (5.29)$$

Where,

Δy : Difference in water surface elevation inside vs outside of the curve.

v : Mean velocity

T : Top width of channel section

g : Acceleration due to gravity

r_c : Radius of curvature

5.10.2 Freeboard

Freeboard of engineered channels should be provided as given in table 5.12:

Table 5. 12: Freeboard in Engineered Channels

S. No.	Discharge (m ³ /s)	Freeboard (mm)
1	Below 3	450
2	3 and above but below 30	600
3	30 and above but below 300	900
4	300 and above but below 3000	1200
5	3000 and above	1500

Source: IS 7784(Part I): 1993

5.10.3 Modification of Natural Channels

Natural channels are either having steep erodible banks or bottom or mild sloped channels that are almost stabilised. Therefore, if such natural channels are to carry the storm run-off from urbanized areas, some form of modifications of the channel is essentially required to stabilize it. Therefore, the following criteria should be ensured while engineering the natural channels:

- i. Lining of bank and bed if necessary
- ii. Channels and overbank capacity shall be adequate for design storm i.e. 25 year return period.
- iii. Channel velocity shall not exceed 2 m/sec or the critical velocity for any particular section with a minimum value of Manning's Roughness coefficient "n", in case of stabilized earthen channel.
- iv. Water surface limits shall be defined so that the flood plain can be zoned and protected.
- v. Drop structures should be constructed to limit flow velocities and control water surface profile, particularly for the initial storm run-off.

5.10.3.1 Channel Linings

Channel linings should be provided wherever the bed and banks are not in stabilized condition and likely to be eroded in high floods in the natural channel. Different types of channel linings are as follows:

- a) Rigid Lining: under rigid lining criteria following type of linings are considered:
 - ✓ Concrete
 - ✓ Precast concrete slab
 - ✓ Stonemasonry
 - ✓ Cellular reinforced concrete paving with infill soil.
- b) Flexible lining: under flexible lining criteria following type of linings are considered:
 - ✓ Rip-rap
 - ✓ Gravels
 - ✓ Gabion or random Rubble

Each type of lining should be scrutinized for its applicability, how it meets other community needs, its long term integrity, maintenance needs, etc. As lining is costly component of a lined channel. Therefore, such shape of channel should be adopted, which has less surface area and more hydraulic capacity. Though semi-circular section provides maximum hydraulic capacity with minimum surface area per unit length, but cost and ease of construction provides preference of trapezoidal section, which is somewhat pragmatic approximation of semi-circular shape. Hence, trapezoidal section is adopted for storm water drains/ channels.

Further, wherever feasible, the bottom of the channel may be kept pervious according to approved design and capacity of storm water runoff to be carried duly accounting for constraints of land availability, etc.

CHAPTER – 6: DESIGN CONSIDERATIONS FOR SPECIAL AREAS

6.1 General

Storm runoff estimation for hydraulic design of storm water drains is elaborated in Chapter 4. However, in the course of storm water drains design, there are many special areas like hilly and coastal terrains which require special consideration in the design. This chapter outlines the additional design criteria for storm water drains under some specific conditions such as control of erosion & sedimentation, dissipation of excess energy of runoff, design of outfall in coastal areas and control of backflow to minimize incidences of waterlogging.

6.2 Hilly Terrain

Hilly areas are characterized with high terrain slope. In case of a storm, the runoff gushes down the hill at very high velocities causing erosion of soil along drains/slopes. The amount and size of soil particles transported, increase the volume and velocity of runoff and are subsequently carried along drainage system of the basin to the receiving bodies e.g., river and stream.

6.2.1 Impact of Erosion and Sedimentation on performance of storm water drains

On steeper slopes, water moves faster as compared to flatter slopes and this increased flow velocity aided by a lack of significant vegetative cover results in transportation of larger amount of sediments. The increasing urbanization of hilly areas increases the paved surfaces and results in increased surface runoff, further aiding the transport of eroded sediments. Deposition of such eroded sediments inflicts serious problems in the drainage channels in the areas located downstream of it resulting in frequent flooding. Rapid downward movement of sediment-laden water can cause problems like landslides that frequently occur during monsoon almost in most of the hilly towns, causing loss of lives and damage to property. Therefore, the interlinked consequences of urban development are transforming the hilly urban watersheds into multi-hazard zones. Protecting erosion and prevention of sedimentation is extremely important in planning and design of urbanization in hilly areas. The following section mentions about the considerations to be adopted in the design of storm water drains to mitigate the issue of erosion and sedimentation.

6.2.2 Additional Design considerations for drainage systems

- i. Storm drains should be constructed on both sides of the road and connected with cross drains across the road at suitable intervals having gratings to collect rainwater from the surface of the road during rains

- ii. Roof water drains should be connected to these drains so that the rainwater may not spill over the slopes
- iii. The collected storm water conveyed through drains should be disposed off in the valley stream through existing natural channels or constructed channels along the slope at a suitable location
- iv. Natural channels should be engineered either by constructing a stepped channel or chute (design guidelines may be seen in chapter 5). The width of such an engineered channel should never be reduced from its existing natural width
- v. Valley stream bank at the point of outfall should be protected by revetment against erosion
- vi. To drain out the increased discharge through the natural channel in a valley, the bank of such channel should be protected by retaining wall made of rock block or gabion box, depending on the steepness of the side slope
- vii. Sufficient weep holes should be provided in case of concrete/masonry retaining walls. Weep holes shall be provided in cement stone masonry walls at a spacing of about 1.5 m centre-to-centre in either direction. The size of weep holes shall be 100 mm to 150 mm connected with PVC (flexible) pipes embedded at 10° down from the horizontal towards the valley.

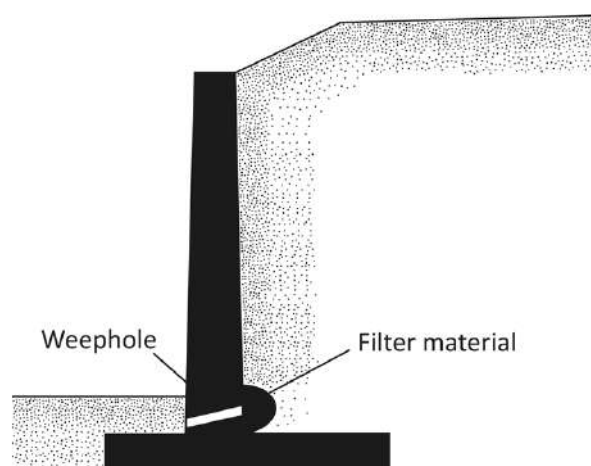

Figure 6. 1: Weep holes in a retaining wall

- viii. For a channel carrying debris and having a moderate slope (say $10^\circ < S < 30^\circ$) intermediate sill projecting from the bed can be constructed to reduce the flow velocity
- ix. For a channel having a thick natural cover of boulders (which is found in most

- of the natural channels), no additional measures are necessary for protection against scouring
- x. In absence of a boulder bed in a moderate slope, a discrete concrete block may be placed to prevent scouring under the impact of high streamflow velocity, while keeping the bed permeable to allow infiltration
 - xi. The road must have adequate cross slope or camber as per Clause 5 of IRC, SP-42 (1994) for quick disposal of storm water runoff laterally to the roadside drain/drains
 - xii. A minimum longitudinal grade of 0.5 % should be provided to the road, wherever possible in order to facilitate surface drainage
 - xiii. Intercepting drain, as in a hilly terrain sloping towards the road, should have adequate size and be connected properly with well-designed culverts/bridges
 - xiv. In case width of terrain contributing flow to the drain is very large, intercepting drain at higher elevation should be provided

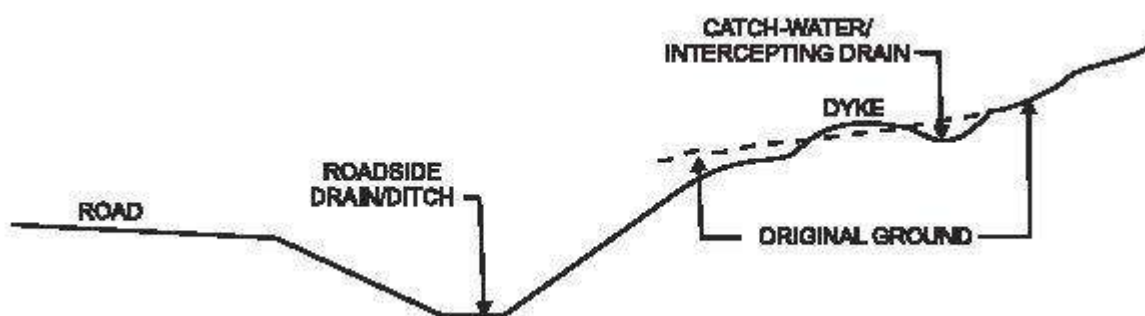

Figure 6.2: Intercepting / Catch Water Drain on a Hill Slope

- xv. To dissipate the energy of flowing water with high velocity down the steep slope in the hilly area, a stepped channel or chute should be provided with a protective apron as given in clause 5.8.1 of chapter 5

6.2.3 Temporary erosion and sedimentation control practices

The temporary erosion and sedimentation control measures to be implemented in the catchment area and the drainage systems are elaborated below:

a) Mulching

Mulching refers to the application of plant residues or other suitable materials to the soil surface to prevent erosion and reduce surface flow velocities. Mulching also fosters plant growth by increasing available moisture and providing insulation against extreme heat or cold. Mulch materials, application rates, and specifications are explained in Table 6.1.

**Figure 6.3: Mulching****Table 6. 1: Mulch materials, application rates and specifications**

Sr. No	Mulch Material	Quality Standards	Application rate	Remarks
1.	Straw	Air-dried, free from undesirable seed and coarse material	50 mm - 75 mm thick, 2000-3000 Kg per 4000 m ²	Cost-effective protection when applied with adequate thickness. Hand-application generally requires greater thickness than blown straw. Straw should be crimped to avoid wind blow. The thickness of straw may be reduced by half when used in conjunction with seeding.
2.	Wood Fiber Cellulose	No growth-inhibiting factors	450 - 680 Kg per 4000 m ²	Shall be applied with hydro mulcher. Some wood fiber with very long fibers can be effective at lower application rates
3.	Compost	No visible water or dust during handling. Must be purchased from supplier with Solid Waste Handling Permit.	50 mm thick min, approx. 100,000 Kg per 4000 m ²	More effective control can be obtained by increasing thickness to 75 mm.

Source: King County, Washington Surface Water Design Manual

b) Temporary/permanent seeding

Temporary seeding and permanent seeding are two types of vegetative controls. Temporary seeding is applied in areas that will be dormant for 15 days or more whereas, permanent seeding is applied in areas that will be dormant for one year or more. Selection of vegetation types depends on the season, site conditions and costs.

Construction guidelines:

1. Prior to seeding, install all necessary erosion control practices such as dikes, waterways, and basins
2. Provide proper shaping of the area to be seeded in a manner such that seedbed preparation and seeding operations can be carried out
3. Soil conditions needed for the establishment and maintenance of seeding must be as follows:
 - a. Sufficient fine-grained material to maintain adequate moisture and nutrient supply
 - b. Sufficient pore space (crumb-like structure or bulk density 1.2 to 1.5 gm/cm³) to permit root penetration
 - c. Sufficient depth of soil to offer an acceptable root zone. The depth to rock layers shall be 0.3 m or more.
 - d. A promising pH range for plant growth. If the soil is so acidic then soil modification would be mandatory.
 - e. Freedom from toxic materials harmful to plant growth
 - f. Freedom from excessive amounts of roots, branches, large stones and trash of any kind

c) Sediment Basins

A sediment basin is a constructed embankment of compacted soil across a drainage way which detains sediment-laden runoff. The basin allows runoff to pond and sediment to settle down. They are generally used where the construction area is disturbed in 2 ha or more. Accumulated sediment within the basin should be removed as necessary.



Figure 6. 4: Sediment Basin

Design Steps:

When constructing a sediment basin, designers should estimate the site constraints that could affect the efficiency of the sediment basin. These constraints include basin capacity, estimated sediment load, and freeboard, maintenance frequency, and hydraulic capacity of outlet structure.

Design sediment basin(s) using the equation:

$$A_s = \frac{1.2 Q}{V_s} \quad (6.1)$$

Where,

A_s : Minimum surface area for trapping soil particles of a definite dimension

V_s : Settling velocity of the design particle dimension chosen ($V_s = 0.0085$ cm/s for a design particle size of 0.01 mm at 68°F)

1.2 : Factor of safety

Q : Peak basin influent flow rate (m^3/sec), which shall be calculated by Rational formula given in Chapter 4

This method is dependent on the outlet structure design. If the designer chooses to utilize the outlet structure to control the flow duration in the basin, the basin length (distance between the inlet and the outlet) should not be less than twice the basin width; the depth should not be less than 0.9 m nor greater than 1.5 m for safety reasons and for maximum efficiency.

d) Check Dams

Check dams are small temporary dams, constructed across a drainage ditch to reduce erosive runoff velocities of concentrated flows. Check dams are limited to use on small open channels draining 4 ha (10 ac) or less. Sediments should be removed when it reaches approximately half the height of the dam. Check dams should be spaced in the channel so that the crest of the downstream dam is at the elevation of the toe of the upstream dam.



Figure 6. 5: Check Dams

Design Steps:

Check dams should follow to the following requirements:

- a) Check dams should be constructed before surface runoff is directed to the swale or drainage ditch
- b) The maximum runoff contributing area to the dam should be lesser than 10 acres
- c) The dam maximum height should be 0.6 m
- d) The centre of the dam should be at least 15 cm lower than the outer edges
- e) The maximum spacing between the dams should be such that the toe of the upstream dam is at the same elevation as the overflow elevation of the downstream dam
- f) The check dam should not be used in a flowing watercourse
- g) Stone check dams should be built of a well-graded 5 cm to 7.5 cm stone. 2 cm stone on the up gradient side is suggested for better filtering.
- h) If sensibly installed and monitored, timber check dams may be used and should be constructed of 10 cm to 15 cm logs embedded at least 45 cm deep into the soil. However, stone check dams are generally chosen. The stone has the capability to conform to the channel and settle if scour happens.

Note: Detailed design may be referred from the 'Manual on Artificial Recharge of Ground Water' published by Central Ground Water Board (CGWB), September 2007.

e) Silt Fences

A silt fence is the most widely used temporary sediment barrier. The fence consists of a filter fabric supported by wooden posts or wire mesh. It is placed across or at the toe of a slope to intercept and detain sediment and reduce flow velocities. The maximum effective life of a silt fence is approximately six months. Proper maintenance of a silt fence requires removal of sediment deposits when necessary. Silt fences which decompose or become ineffective prior to the end of the expected useable life should be replaced immediately.



Figure 6. 6: Silt Fence

Design Criteria:

- I. Ensure silt fence height is a minimum of 400 mm above ground level
- II. Place supporting posts for silt fences no more than 2 m apart unless additional support is provided by tensioned wire (2.5 mm HT) along the top of the silt fence
- III. Ensure supporting posts are embedded a minimum of 400 mm into the ground
- IV. Always install silt fences along the contour
- V. Join lengths of silt fence by doubling over fabric ends around a wooden post or batten or by stapling the fabric ends to a batten and butting the two battens together
- VI. Install silt fence wings at either end of the silt fence projecting upslope to a sufficient height to prevent outflanking
- VII. Do not use silt fences in catchments of more than 0.25 ha

f) Brush Barrier

A brush barrier is a temporary sediment barrier composed of materials (such as weeds, vines, root mats, soil, rock, etc.) pushed together at the perimeter of a given site and at the toe of fills. Maintenance measures include inspection following each rainfall and

removal of sediment deposits when they reach half of the barrier height.

The height of a brush barrier shall be a minimum of 1 m. The width of a brush barrier shall be a minimum of 1.5 m at its base (the sizes of brush barriers may vary considerably based upon the amount of material available and the judgment of the design engineer). Material larger than 15 cm in diameter should not be used as the non-homogeneity of the mixture can lead to voids where sediment-laden flows can easily pass.

The drainage area for brush barriers should not be greater than 0.1 ha per 30 m of brush barrier length. Additionally, the drainage slope leading down to a brush barrier must be not greater than 3:1 and no longer than 45 m.



Figure 6.7: Brush Barrier

g) Diversion Dike

A diversion dike is constructed of compacted soil and is used to divert runoff to an acceptable location. They are placed either at the top of a disturbed area to divert site runoff, or at the bottom to deflect sediment-laden runoff to a sediment trapping structure. Dikes should be inspected weekly and after rainfall events and repairs made as necessary. Following are the installation criteria of diversion dike:

- a. Clear and grub area for diversion dike construction
- b. Excavate channel and place soil on the down gradient side
- c. Shape and machine compact excavated soil to form a ridge
- d. Place erosion protection (riprap, mulch) at the outlet
- e. Stabilize channel and ridge as required with mulch, gravel, or vegetative cover

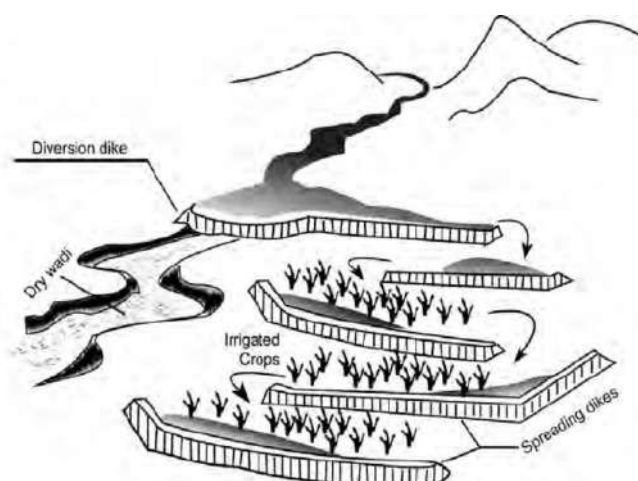

Figure 6.8: Diversion Dike

h) Temporary slope drains

A slope drain is a flexible tubing or conduit used to convey concentrated runoff from the top to the bottom of a disturbed area without causing erosion on or below the slope. It can also be used to carry storm water down a slope away from a control facility. Slope drains should be inspected weekly and after rainfall events to ensure proper operation.

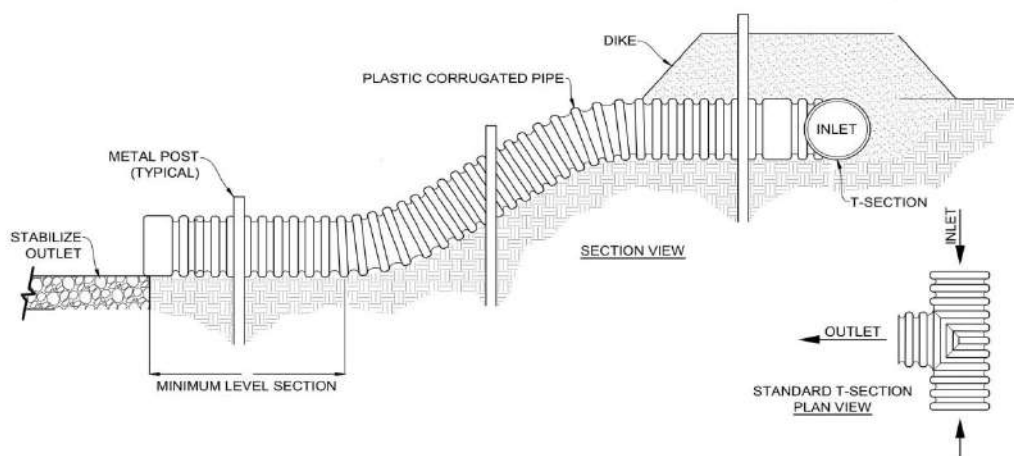

Figure 6.9: Temporary Slope Drain

The temporary slope drain must be sized to safely convey the desired flow volume. Temporary slope drains may be constructed of flexible or rigid pipe, riprap, or heavy plastic lining. When piping is used, it must be properly anchored by burying it with adequate cover or by using an anchor system to secure it to the ground.

The discharge from the slope drain must be directed to a stabilized outlet, temporary or permanent channel, and/or sedimentation basin.

6.3 Coastal Terrain

The coastal areas present a unique challenge to the design of storm water drainage systems, owing to tides, high groundwater tables, and relatively flat terrain. During high tides, low lying areas along the coast are prone to flooding/inundation and disposal of storm water becomes a problem. During severe storms/cyclones, the discharge of storm water through drains is often not effective and results in water logging and flooding. Backflow of sea water further exasperates the problem. The following section mentions the special design considerations in storm drainage outfalls in coastal areas.

6.3.1 Design Considerations for storm water drainage in Coastal Areas

The following measures suggested should also be incorporated in design for efficient discharge of storm water in coastal areas:

- a) Encouraging infiltration through low impact development activities, such as preserving & recreating natural landscape features, bio-retention facilities, vegetated rooftops, permeable pavements, etc.
- b) Installing pumps to provide sufficient pressure to storm water to overcome backflow during sea-level rise. Alternatively, a suitable pumping system or a combination of systems shall be implemented so as to minimize flooding in low lying areas during high tide periods
- c) Installing check valves/ flap gates to only allow outflow from storm water conduits and effective prevention of backflow
- d) Trench drains are recommended in locations where there is localized flooding at a low point in a paved area
- e) Avoid pipes discharging on beaches
- f) Avoid construction of conduit/channels along the shoreline
- g) Minimize the number of outlets into the sea or estuary



Figure 6.10: Trench Drain

6.3.2 Storm outfalls in coastal towns/cities

Tide levels can influence storm water drainage planning since a significant portion of the drainage infrastructures in the coastal cities is dependent on outfalls having a tidal influence of the surrounding sea and estuaries. The establishment of engineering design values for the still water levels or tail water elevations, utilized in drainage outfall hydraulic analysis for storm water management planning should also account for rising sea level trends over a projected period of time to ensure that the planned drainage improvements will function effectively under current tidal water conditions, as well as, future conditions.

6.3.3 Sea levels in different conditions

Variation in seawater levels is essentially required to be understood in its various phases of tidal events before concluding the desired seawater elevation for positioning the storm outfall levels in coastal areas of the sub-continent. The pictorial illustration of the tidal levels is shown in Figure 6.11. The following sections briefly discuss the various relevant aspects:

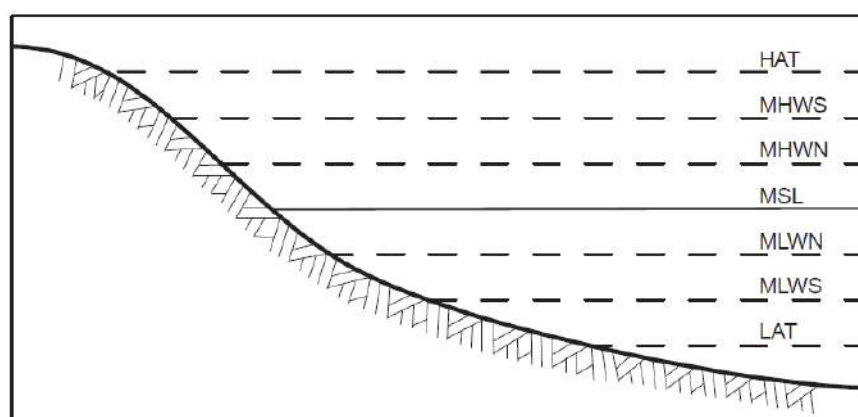

Source: Adapted from 'Queensland Urban Drainage Manual'

Figure 6.11: Sea levels

a) Tidal water levels

Chart datum is plane below which all depths are published on a navigational chart. It is also the plane to which all tidal heights are referred, so by adding the tidal height to the charted depth, the true depth of water is determined. By international agreement, chart datum is defined as a level so low that the tide will not frequently fall below it.

b) Mean sea level

Mean sea level (MSL) is average level of the sea surface over a long period normally 19 years or the average level which would exist in the absence of tide, i.e. the average height of surface of the sea at a tide station for all stages of the tide over years of period. The MSL is usually determined from hourly height readings measured from a fixed predetermined reference level (chart datum).

c) Highest Astronomical Tide (HAT) and Lowest Astronomical Tide (LAT)

The highest and lowest tide levels respectively can be predicted to reach under average meteorological conditions or under any combination of astronomical conditions but are not the regular occurrence. These levels will not be reached every year.

d) Spring Tides

During the full moon and new moon phases of a Lunar cycle (approximately a fortnightly occurrence), the gravitational forces of the moon and the sun act to reinforce one another. The tides experience an increased range during these phases. Since the combined tidal force is increased, the high tides are higher and the low tides are lower than the average. Spring tide is a term which implies a welling up of the water and bears no relationship to the season of the year.

e) Neap Tides

The tides of decreased range occurring near the times of first and third quarter phases of the moon when the gravitational forces of the moon and the sun counteract each other. As the combined tidal force is decreased, the high tides are lower and the low tides are higher than average. Neap comes from a Greek word meaning scanty.

f) MHWS (Mean High Water Springs) & MLWS (Mean Low Water Springs)

The height of mean high water springs is the average of the heights of two successive high waters during those periods of 24 hrs (approximately once a fortnight) when the range of the tide is greatest. The height of mean low water springs is the average height obtained by the two successive low waters during the same period i.e.

MHWS The average height of the high waters of spring tides above Chart Datum

MLWS The average height of all low waters of spring tides above Chart Datum

g) MHWN (Mean High Water Neaps) & MLWN (Mean Low Water Neaps)

The height of mean high water neaps is the average, throughout a year as defined above, of the heights of two successive high waters during those periods (approximately once a fortnight) when the range of the tide is least. The height of mean low water neaps is the average height obtained from the two successive low waters during the same periods, i.e.

MHWN The average height of the high waters of neap tides above Chart Datum

MLWN The average height of the low waters of neap tides above Chart Datum

h) Storm surge

A storm surge (meteorological tide) is an atmospherically ocean driven response by extreme surface winds and low surface pressure associated with severe weather conditions, usually cyclones. Strong off-shore winds can generate significant ocean currents when these currents approach a barrier such as shorelines, sea levels increase as the water is forced up against land. The low atmospheric pressure associated with cyclones can also raise sea levels well above predicted tide levels.

i) Historical sea levels

Historical sea levels are instrumental records of sea-level changes measured with permanent tide gauges at required locations. Such gauges are installed at 28 locations along Indian coastline operated and maintained by Survey of India.

j) Availability of Tidal Data

The annual and monthly MSL tide gauge data can be obtained from Permanent Service for Mean sea level (PSMSL) and the satellite altimetry data from Topex/Poseidon Jason 1 and Jason 2. There are 28 tide gauge stations along the Indian coastline. Necessary data can be obtained, recorded by these gauges from Survey of India, Dehradun. Global data can also be obtained from the Water Ocean Circulation Experiment (WOCE), National Oceanographic Data Centre (NODC), and Indian National Centre for Ocean Information Service (INCOIS), Hyderabad, etc. Besides, national port and harbor authorities of maritime board of coastal states of India also publish annually, tide tables recorded at the minor ports within jurisdiction of their state.

6.3.4 Global trend in sea level variation

Based on major findings of IPCC scientific assessment of working group (2014), it is anticipated that if greenhouse gas emissions continue to increase at the current rate,

an average rate of global sea-level rise between 3 cm and 10 cm per decade is predicted over the next century, resulting mainly from thermal expansion of the ocean.

6.3.5 Regional trend in sea level variation

Recent studies on regional sea variation along the Indian coast (APAC-2015) reported that average rise in MSL in the Bay of Bengal and the Arabian Sea based on available tide gauge data-set have been found to be 1.92 mm/year and 1.72 mm/year respectively.

6.3.6 Design considerations for tidal outfall in ocean and bays

Selection of appropriate tail water level at the location of storm water outfall is the basic necessity in design and planning of storm water drainage system of coastal cities. The nature of tidal variation, storm surges, mean sea level, wave set up, and climate change effect, that significantly influences tail water level, have been briefly described in the foregoing sections.

However, the local maritime board of state Government and/or other local authorities should be consulted to establish an appropriate tail water level for design of storm outfall to ocean/ bay. Consideration should also be given to the joint probability of occurrence of the design storm, tide level, and storm surge. The effect of increased tail water level resulting from climate change should be examinedriverbankand necessary allowance should be made in determining the tail water level. Suggested tail water level for discharge to tidal waterways in design of storm outfall system are given in Table 6.2.

Table 6. 2: Design considerations for tidal out fall

Design condition	Design tail water level
Minor storm (< 1 in 5 years)	In the range of MHWN to MHWS
Major storm (> 1 in 5 years)	In the range of MHWS to HAT
Effect of climate change	Additional 0.3 m

6.3.7 Design consideration for outfall in tidal rivers and streams

In case where the drainage outfall is located in the tidal reach of a stream or river, water levels within receiving waters may be affected by flood flows passing down the receiving waterway. The severity of this coincident flooding will depend principally on the ratio of the time of concentration of the side channel/drain relative to that of the receiving waterway. The procedure described in section 4.4.1.7 (Partial area effect) may be adopted to assess the most critical combination of flows and stream water level. Therefore, a tail water level should include an appropriate surcharge to the

corresponding flood discharge, in addition to the stream water level. Such case may also arise in non – tidal rivers that should be dealt with accordingly.

Table 6. 3: Design tail water level

Design condition	Design tail water level
Minor storm (< 1 in 5 years)	In the range of MHWN to MHWS
Major storm (> 1 in 5 years)	In the range of MHWS to HAT
Effect of climate change	Additional 0.3 m
Surcharge due to the combined discharge of side drain and mainstream	As per design calculation in Chapter 4, clause 4.4.1.7 of Partial area effect

Alternatively, local authorities and maritime boards may determine appropriate tail water levels or discharge conditions of particular reaches of tidal streams based on local experience and knowledge.

6.3.8 Design tail water level for non-tidal storm outlets

Design tail water level for the following non-tidal water bodies may be adopted as follows:

- For river and streams – High Flood water level (HFL)
- For lakes - Normal high water level or overflow level
- For storm water ponds – Normal high water level or overflow level

6.3.9 Outfall Structure

Typical drawing of outlet structure for river/streams is given in Figures 6.12 and 6.13:

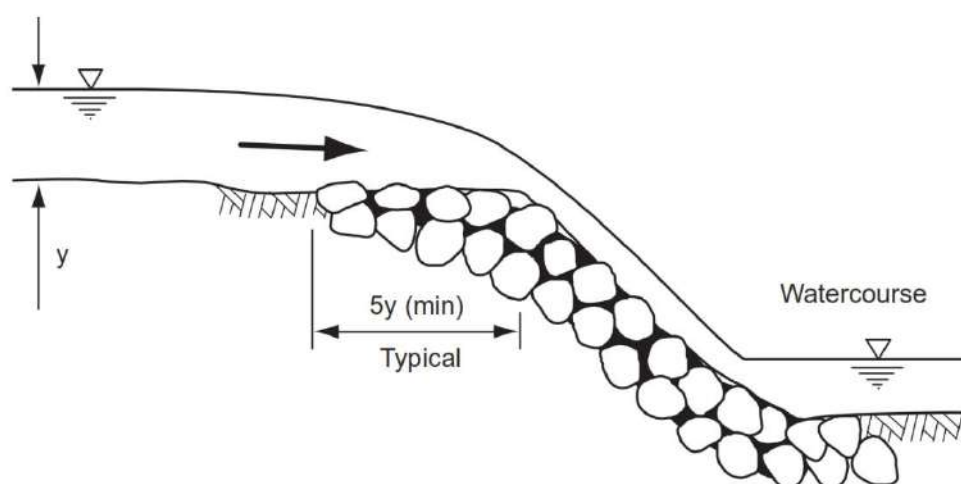

Figure 6. 12: Storm Water channel outfall

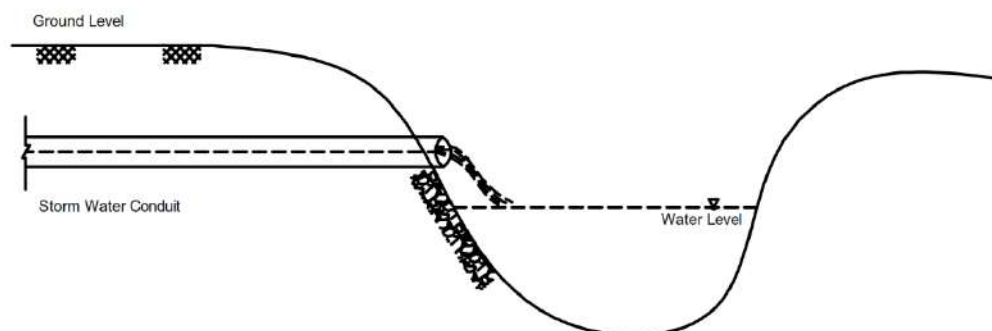

Figure 6. 13: Storm Water Conduit outfall

- a. The Boulder or stone pitching should be done over the bank of the river to protect against erosion of the bank.
- b. The pitching should extend 5 times the depth of outfall storm water channel/conduit
- c. Barricades should be installed wherever applicable to safeguard against any type of damage to the structure

6.3.10 Backflow control Systems

Storm water pipes and drains can be subject to backflow in circumstances where flood levels within the receiving water rise above the water level within the pipe or drain. Backflows can be the result of normal tidal action or a result of river flooding. Backflow prevention devices are used when it is desirable to limit the degree of backflow or likelihood of backflows. The most common types of backflow prevention devices include flap gates and mechanically operated gates. Backflow prevention devices can be used for the following reasons:

- a. To reduce the risk of coastal sediment/sand inflows into tidal drains
- b. To reduce saltwater intrusion into established freshwater habitats
- c. To reduce the frequency and/or severity of backwater flooding of low-lying land adjacent floodplains
- d. To reduce the floodwater inundation of flood-prone land protected by flood control levees

6.3.10.1 Flap Gates and Flood Gates

Flap gates are installed at or near storm drain outlets for the purpose of preventing back flooding of the drainage system at the high tides or high surges in the Receiving Ocean or tidal streams. Small differential pressure on the back of the gate is kept so that the flap should open at a very small head differential. Flap gates are typically made of cast iron, or rubber or steel and available in round square and rectangular

opening and in various design and sizes. Adequate storage may be necessary if pumping is to be avoided during the closure of the gate to prevent backflow in case of the high tide. To control this flow from the storage tank, Flap gates or penstocks are provided which can be opened and closed quickly at the predetermined stages of high rise of river or sea level. The gates generally have electrical drive mechanisms. Flap gate is usually hinged by key and lock type arrangement that makes it possible to get the gate shutters seated firmly. Hinge pins, links, etc. should be of corrosion-resistant materials.

6.4 River bank protection

The river passing through populated areas of towns and cities may cause excessive damage to adjacent land, properties, hydraulic structures, etc. due to failure of the banks caused by erosive forces of fast-moving currents. It, therefore, necessitates the protection of river banks against erosion and caving, resulting in subsequent failure and collapse. Detailed design and engineering of riverbank protection are beyond the scope of this manual. In this regard the provisions of “Handbook for Flood Protection, Anti Erosion and River Training Works” published by Central Water Commission, Government of India are to be followed.

CHAPTER 7: STRUCTURAL DESIGN OF BURIED STORM WATER CONDUITS**7.1 General**

Hydraulic design of storm water conduits has been discussed in Chapter 5. These pipes, when laid underground, are subjected to forces that need consideration of various parameters such as pipe material properties, supporting strength and various installation and loading conditions like fill loads, superimposed loads, sub-surface water level, etc. This Chapter describes the process of the structural design of underground rigid and flexible conduits under non-pressure flow application that are generally used in storm water drainage system.

7.2 Type of Buried Pipes

There are two types of conduits that are generally used in storm drainage system namely:

- i. Rigid Pipes
- ii. Flexible Pipes

7.2.1 Design of buried rigid pipe

Manual on sewerage and sewage treatment published by CPHEEO, 2013 may be referred for design procedure for underground buried rigid pipes.

7.2.2 Design method of buried flexible pipe

Flexible pipe (non-pressure flow) derives its load carrying capacity from its flexibility. Under vertical load, the pipe tends to deflect pressure on soil support along its sides. At the same time, ring deflection relieves the pipe of the major portion of the vertical load, which is then carried by surrounding soil through a mechanism of soil arching action over the pipe. Therefore, the design of flexible pipes involves calculation of deflection, buckling and wall thrust under total load including soil load, vehicular load, and hydrostatic forces so that the pipe must be able to withstand these forces to remain structurally stable.

7.2.2.1 Deflection in flexible pipe

The effective strength of the flexible pipe soil system is remarkably high, which is determined by vertical deflection under pipe soil system. As per IS code 16098:2013 (part II), the deflection limit for various classification of PE pipe is given in Table 7.1.

Table 7. 1: Recommended Design Deflection Limits

S.No.	Stiffness Class	Average Initial Deflection Percent	Average Long term Deflection Percent
i.	SN 2	5	8
ii.	SN 4, 8,16	8	10

Source: IS code 16098:2013 (part II)

Following formula is applied to compute the vertical deflection in buried flexible pipe for short term and long term conditions:

$$\frac{\Delta y}{D_M} = \frac{K(D_L W_c + W_L)}{\left(\frac{8EI}{D^3}\right) + (0.061 \times E')} \times 100 \quad (7.1)$$

Where,

$\frac{\Delta y}{D_M}$: Deflection in %

K : Bedding Constant (dimensionless);

D_L : Deflection lag factor (dimensionless);

W_c : Soil Column load on pipe, kPa

W_L : Live load, kPa

$\frac{EI}{D^3}$: Ring Stiffness in kPa which is designated as SN by IS code 16098:2013 (Part II)

E' : Modulus of soil reaction in kPa

D_M : Mean Diameter, m

(a) Loading on pipe

The loading on buried pipes is composed of dead load and live load i.e.

(i) Dead load, kPa (W_c)

Dead load is the soil Column load on pipe which is calculated by the following formula:

$$W_c = H \times \gamma_s \quad (7.2)$$

H : Burial depth to top of pipe, m

γ_s : Soil density, kN/m³

(ii) Live load, kPa (W_L)

The live load is imposed by a source moving over the buried pipe, such as vehicles on a road, railway or load at an airport. The determination of live load is important for shallow burial of less than 3.1 m. The effect of live load decreases as the depth of cover increases. A table of live loads has been developed for highways and railways which are given in the Table 7.2.

Table 7. 2: Live Loads on Flexible Pipes

Height of Cover (m)	Highway HS-25		Railway E80
	P_L (N/mm ²)	Distribution Width (L_w) (mm)	P_L (N/mm ²)
0.3	0.108	787	N.R
0.6	0.048	1321	0.1824
0.9	0.036	1854	0.1632
1.2	0.024	2388	0.1272
1.5	0.015	2921	0.1152
1.8	0.012	3454	0.1080
2.1	0.011	3988	0.0846
2.4	0.006	4521	0.0768
3.1	N.S	N.S	0.0528
3.6	N.S	N.S	0.0384
4.3	N.S	N.S	0.0288
4.9	N.S	N.S	0.0240
5.5	N.S	N.S	0.0192
6.1	N.S	N.S	0.0144
6.7	N.S	N.S	0.0132
7.3	N.S	N.S	0.0120
7.9	N.S	N.S	0.0096
8.5	N.S	N.S	0.0072
9.1	N.S	N.S	0.0048
10.7	N.S	N.S	N.S
12.2	N.S	N.S	N.S

Source: AASHTO

Notes:

- 1) Includes impact where required.
- 2) N.R indicates that the cover height is not recommended.
- 3) N.S indicates that the load is non-significant.

(b) Deflection lag factor, DL

For initial deflection, deflection lag factor is taken as 1.0. Long term deflection depends on embedment and compaction of the soil. However, for conservative design, lag factor can be considered as 1.5 for long term condition.

(c) Soil modulus E'

The most commonly recognised values of soil modulus E' are those of Amster Howard of the US Bureau of Reclamation. Howard examined the information from known laboratory and field tests and developed a table of average values of E' which is given in Table 7.3 for computation of deflection of buried flexible pipes.

Table 7. 3: Average Values of Modulus of Soil Reaction E' for Initial Flexible Pipe Deflection

E' for degree of compaction of bedding				
Soil type pipe bedding material(Unified Soil Classification System)	Dumped	Slight <85% Proctor, <40% relative density	Moderate 85-95 % Proctor, 40-70% relative density	High, >95% Proctor, >70% relative density
	KPa	KPa	KPa	KPa
Fine grained soils (LL<50) Soils with medium to no plasticity CL, ML, ML-CL with less than 25% coarse – grained particles	345	1379	2758	6895
Fine grained soils (LL<50) Soils with medium to no plasticity CL, ML, ML-CL with more than 25% coarse – grained particles Coarse grained soils with fines GM, GC, SM, SC containing more than 12% fines	690	2758	6895	13789
Coarse grained soils with little or no fines GW, GP, SW, SP containing less than 12% fines	1379	6895	13790	20684
Crushed rock	6895	20684	20684	20684
Accuracy in terms of percentage of deflections	±2	±2	±1	±0.5

Source: Amster K. Howard, U.S. Bureau of Reclamation, Denver, "Modulus of Soil Reaction (E') Values for Buried Flexible Pipe,"

Note: Values given in Table 7.3 are consistent with field and laboratory data taken over a 20 year period at Utah State University.

(d) Bedding constant, K

The bedding constant is a term which accounts for the reactive force imparted from the pipe bedding material when a pipe is installed. The bedding constant is determined from the bedding angle, as shown in figure 7.1. Values of bedding angles and approximate constants are given in Table 7.4. For most installations the bedding constant is assumed to be 0.1.

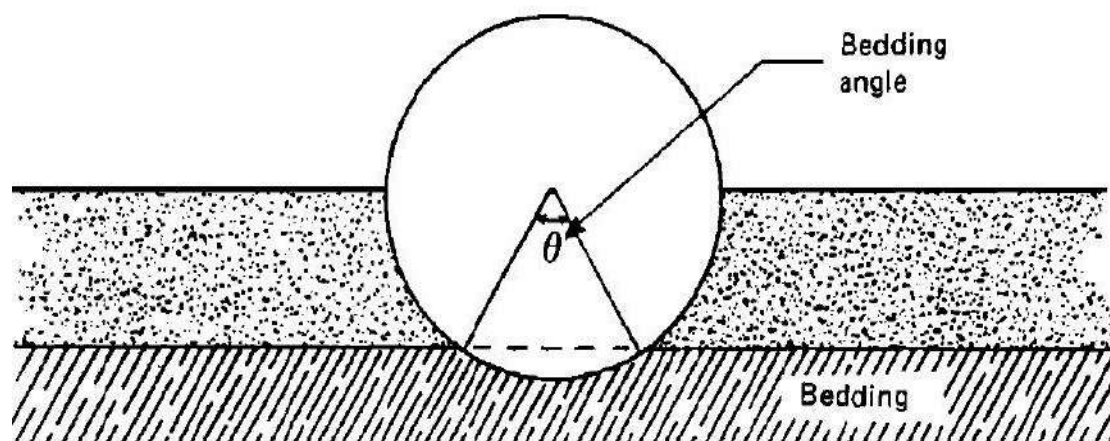

Figure 7.1: Bedding Angle

Table 7. 4: Value of constant (K)

Bedding angle in degree	K
0	0.110
30	0.108
45	0.105
60	0.102
90	0.096
120	0.090
180	0.083

(e) Pipe properties

Pipe properties of PE pipes are given in Table 7.5 as per IS code 16098:2013 (Part II).

Table 7.5: Nominal size, Minimum Mean Inside Diameters, Thickness of inside Layers and Socket Length

SI No.	DN/ID Series		Minimum Wall Thickness		Socket ¹⁾ Length
	DN/ID	$d_{im,Min}$ mm	$e_{4,Min}$ mm	$e_{5,Min}$ mm	A_{Min} mm
(1)	(2)	(3)	(4)	(5)	(6)
i)	75	71	1.0	0.85	27
ii)	100	95	1.0	1.0	32
iii)	125	120	1.2	1.0	38
iv)	135	130	1.2	1.0	39
v)	150	145	1.3	1.0	43
vi)	170	165	1.4	1.0	48
vii)	200	195	1.5	1.1	54
viii)	225	220	1.7	1.4	55
ix)	250	245	1.8	1.5	59
x)	300	294	2.0	1.7	64
xi)	400	392	2.5	2.3	74
xii)	500	490	3.0	3.0	85
xiii)	600	588	3.5	3.5	96
xiv)	800	785	4.5	4.5	118
xv)	1000	985	5.0	5.0	140
xvi)	1200	1185	5.0	5.0	162

1) For selection of A_{min} requirements for socket, refer to the pipe material and construction. For pipe longer than 6 m it is recommended that one produce a larger A_{min} that is specified in this table

Where,

$D_{im, Min}$: Minimum mean inside diameter of a socket

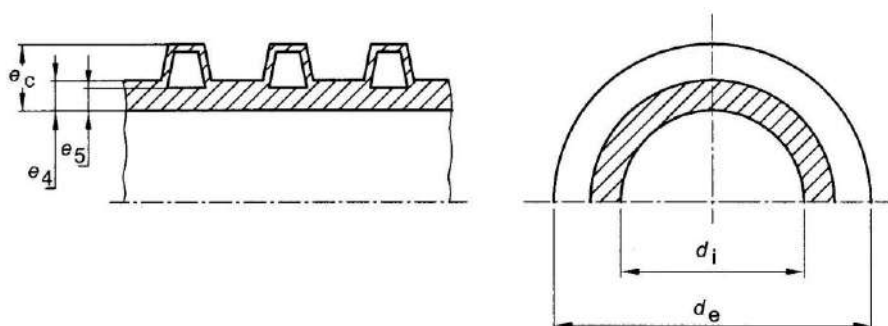

Where,

e_4 : Wall thickness of the inside layer (waterway wall thickness)

e_c : Construction height

d_e : Outside diameter

d_i : Inside diameter

Note:

- i. The internal diameter (DN/ID) shall be as per Table 7.5. Other nominal sizes, falling within the range of Table 7.5, are also permitted. For DN/IDs not specified in Table 7.5, the minimum inside diameter, $d_{im, Min}$, shall be linearly interpolated between the adjacent values specified in Table 7.5.
- ii. Values of pipe properties should be obtained from the manufacturer for a specific type of flexible pipe.

Table 7.6: Physical properties of PE pipe

Sl. No.	Characteristics	PE
1	Flexural Modulus, E_{min} in MPa	1000-1200
2	Density, kg/m^3	950
3	Poisson's ratio	0.4

Source: Adapted from IS code IS 16098:2013 (Part II)

Note: For long term condition, flexural modulus may be assumed as 30% of the initial modulus as given in Table 7.6 for purpose of design.

(f) Pipe stiffness(PS)

Pipe stiffness value should be provided by pipe manufacturer or can be determined theoretically by the following equation.

$$PS = 6.71EI/r^3 \quad (7.3)$$

Where,

PS : Pipe stiffness in KPa

E : Modulus of elasticity in KPa

I : Moment of inertia in mm^4/mm

r : Mean pipe radius in mm

7.2.2.2 Buckling Pressure

Buckling of pipe is a localized failure of the pipe wall structure which is due to insufficient pipe stiffness, deep burial with high ground water table, internal vacuum or poor backfill condition. Therefore, the pipe should be checked for critical buckling pressure against actual buckling pressure giving a factor of safety greater than or equal to 2.

Factor of safety (FS) = Critical Buckling Pressure / Actual Buckling Pressure

a) Critical Buckling Pressure

Critical Buckling pressure is calculated by the following formula:

$$P_{cr} = 0.6(EI/D^3)^{0.33}(E')^{0.67} \quad (7.4)$$

Where,

P_{cr} : Critical Buckling Pressure, kPa

EI/D^3 : Ring stiffness (SN) of pipe

E' : Average Values of Modulus of Soil Reaction E'

The long and short term values of SN are used to calculate P_{cr} and P_{crs} , respectively. (For metal pipes, the long term and short term moduli are identical)

b) Actual Buckling Pressure

Actual Buckling pressure is calculated by the following formula:

$$P_v = 0.00981\{(R_w H \gamma_s + \gamma_w H_w)\} + \frac{1000W_L}{OD} \quad (7.5)$$

Where,

P_v : Actual buckling pressure, kPa

R_w : Water buoyancy factor = $1 - 0.33 \left[\frac{H_w}{H} \right]$

H : Burial depth to top of pipe, m

γ_w : Unit weight of water, 1000 Kg/m³

H_w : Height of ground water over top of pipe, m

W_L : Live load, N linear mm of pipe = OD × P_L

OD: Outside diameter of pipe in mm

γ_s : Soil density Kg/m³

The following example shall elucidate the application of the above mentioned formulae in designing and checking the flexible pipe installation and its stability.

Example 7.1

400 mm (SN 8) inside diameter and 480 mm outside diameter corrugated polyethylene pipe is to be installed having a minimum cover of 0.5 m. Ground water is below the invert of the pipe. Backfill materials are native soil compacted to 85-95% SPD. The density of the backfill material is 15 kN/m³. Check whether the pipe shall be structurally stable under the aforesaid installation conditions?

Solution:**i. Check for Deflection:**

$$\frac{\Delta y}{D_M} = \frac{K(D_L W_c + W_L)}{\left(\frac{8EI}{D^3}\right) + (0.061 \times E')} \times 100$$

Where,

$$K = 0.1$$

$$D_L = \text{For initial deflection} = 1.0 \text{ and for long term deflection} = 1.5$$

$$W_c = \gamma_s \times H = 15 \times 0.5 = 7.5 \text{ kPa}$$

$$W_L = 68 \text{ kPa as per Table 7.2 (by interpolation)}$$

$$\frac{EI}{D^3} = 8 \text{ kPa (Value of SN by manufacturer)}$$

$$E' = 6895 \text{ kPa from Table 7.3}$$

For short term condition

$$\frac{\Delta y}{D_M} = \frac{0.1(1 \times 7.5 + 68)}{(8 \times 8) + (0.061 \times 6895)} \times 100 = 1.56 \%$$

$$\text{Deflection (\%)} = 1.56 \%$$

For long term condition

$$\frac{\Delta y}{D_M} = \frac{0.1(1.5 \times 7.5 + 68)}{(8 \times 0.3 \times 8) + (0.061 \times 6895)} \times 100 = 1.8 \%$$

ii. Check for Buckling**a. Critical Buckling Pressure**

$$P_{cr} = 0.6(EI/D^3)^{0.33}(E')^{0.67}$$

$$P_{crs} = 0.6(8)^{0.33}(6895)^{0.67} = 444.6 \text{ k Pa}$$

$$P_{crl} = 0.6(2.4)^{0.33}(6895)^{0.67} = 298.83 \text{ kPa}$$

b. Actual Buckling Pressure

$$R_w = 1 - 0.33 \left[\frac{H_w}{H} \right] = 1 - 0.33 \left[\frac{0}{0.3} \right] = 1$$

$$P_v = 0.00981 \{ (R_w H \gamma_s + \gamma_w H_w) \} + \frac{1000 W_L}{OD}$$

$$P_v = 0.00981 \{ (1 \times 0.5 \times 1500 + 1000 \times 0) \} + \frac{0.068 \times 480 \times 1000}{480}$$

$$P_v = 7.35 + 68 = 75.36$$

$$FS = P_{cr1}/P_v = 298.83/75.36 = 3.96 > 2$$

Hence, Design is Safe

$$FS = P_{crs}/P_v = 444.6/75.36 = 5.89 > 2$$

Hence, Design is Safe

CHAPTER – 8: STORM WATER PUMPING**8.1 General**

Urban storm water drainage system may encounter situations where gravity flow conditions may not be feasible either due to the topographical configuration of low lying or tidal areas and also where the water level of receiving water bodies is higher than the water level of the outfall. Pumping of storm water becomes an imperative need to avoid flooding and waterlogging of the area under such situations.

8.2 Planning of Pumping Station

Planning of pump station presents the designer with a challenge to provide a cost-effective drainage system that meets the need of the project. Several important considerations are involved in planning and site selection for the pump station. The easy access necessary for safe operation, maintenance, and emergency functions must be available at all times. Hydraulic conditions will have primary importance in site selection, but site appearance and sound attenuation should be also assessed. In normal circumstances, the location of the pump station is usually at the drainage system outlet.

Foundation investigations are necessary, and enough space must be provided in the area outside the station to accommodate parking as well as movements of large machinery. A dependable energy source is essential. The primary source of electrical power for most storm water pump stations is a public utility. Underground service is preferred for safety and aesthetic reasons, and overhead lines into the station should be avoided, as they present potential safety hazards during large equipment operation.

The essential components that require to be considered in the preparation of the layout for the pumping station are as follows:

- a. Location of the pumping point
- b. Pump sump
- c. Storage reservoir
- d. Power Source
- e. Electrical & Mechanical equipment
- f. Access to site
- g. Aesthetics of Pumping Station
- h. Environmental quality

8.2.1 Location of the Pumping Point

Location of pumping station should be selected on dry ground free from flooding risk. However, in cases where pumping location lies in low point/flood-prone area on account of topographic consideration, the pumping station floor on which the electrical equipment and related accessories are placed should be at higher elevation.

8.2.2 Pump sump

Space for pump and sump should be assessed either for the dry wet pump which is having separate sump or Wet well pump which contains the sump inside the pump house

8.2.3 Storage Reservoir

Storage may be a necessary component where reduction of peak flow is desired considering downstream drainage system or receiving bodies of water. In such cases, adequate land area may be required.

8.2.4 Power Source

Electrical power supply source from electrical transmission grids should be the best economical option. Transmission grid should be as near as possible to the pumping station to avoid a quite high-cost involvement in obtaining the power supply from the distant grid.

8.2.5 Electrical & Mechanical Equipment

The pump house should have adequate space to house electrical and mechanical equipment such as switchboard, control panels, transformer, generator room, etc. As per Indian Electricity Rules, the space required for these is given below:

- (a) Sufficient space should be available in the pump house to locate the pump, motor, valves, piping, control panels, and cable trays in a rational manner with easy access and with sufficient space around each equipment for the maintenance and repairs.

The minimum space between two adjoining pumps or motors should be 0.6 m for small and medium units and 1 m for large units.

- (b) Space for control panels should be planned as per the Indian Electricity (I.E) Rules. As per these:
 - (i) A clear space of not less than 915 mm in width shall be provided in front of the switchboard. In case of large panels, a draw out space for the circuit

- breakers may exceed 915 mm. In such cases, the recommendations of the manufacturer should be followed.
- (ii) If there are any attachments or bare connections at the back of the switchboard, space if any behind the switch-board shall be either less than 230 mm or more than 750 mm in width measured from the farthest part of any attachment or conductor
 - (iii) If the switchboard exceeds 760 mm in width, there shall be a passageway from either end of the switch-board clear to a height of 1830 mm
- (c) A service bay should be provided in the station with such space that the largest equipment can be accommodated there for overhauling and repairs
- (d) A ramp or a loading and unloading bay should be provided. In large installations, the floors should be so planned that all piping and valves can be laid on the lower floor and the upper floor should permit free movement.
- (e) Head room and material handling tackle:
- (iv) In the case of vertical pipes with hollow shafts motors, the clearance should be adequate to lift the motor clear off the face of the coupling and also carry the motor to the service bay without interference with any other apparatus. The clearance should also be adequate to dismantle and lift the largest column assembly.
 - (v) In the case of horizontal pumps (or vertical pumps with solid shaft motors), the headroom should permit transport of the motor above the other apparatus with adequate clearance
 - (vi) The mounting level of the lifting tackle should be decided considering the above needs and the need of the headroom for the maintenance and repair of the lifting tackle itself
 - (vii) The traverse of the lifting tackle should cover all bays and all apparatus.
 - (viii) The rated capacity of the lifting tackle should be adequate for the maximum weight to be handled at any time

8.2.6 Access to site

There should be easy access to the pump station for heavy vehicles carrying machineries, hoisting equipment, etc., that are likely to be used during construction and maintenance. Sufficient space should be provided for service road, off-street parking, station loading area, turn around area, heavy lifting equipment, roadside warning signs including above-stated land requirement.

8.2.7 Aesthetics of pumping station

Typical low-cost measure to enhance visual quality should be employed:

- a. Allowing adequate area of natural and planted vegetation
- b. Enclosing unsightly objects such as storage tank etc.
- c. Using submersible pumps to reduce the size of required above ground facilities
- d. Using local building materials that blend in with the surrounding architecture
- e. Providing underground utilities (power supply, phone lines, etc.)

8.2.8 Environmental Quality

Following environmental qualities may be considered.

8.2.8.1 Air Quality

Diesel generators or engine driven pumps are potential air quality pollutants that may be replaced by natural gas or purely grid-supplied electrical energy.

8.2.8.2 Noise

Noise attenuation is a necessary concern near residential areas. Wherever practicable one or more of the following measures may be adopted:

- a) Use submersible pump
- b) Where submersible pumps are not practicable, use an electrically driven motor if engine is used, provide mufflers
- c) Build a pump house from concrete or masonry
- d) Sound insulation of the pump house wall may be an option

An environmental audit should be carried out at regular intervals.

8.3 Design of Pumping Station

8.3.1 Type of pump stations

Two types of pump stations are constructed for the purpose of storm water pumping viz, wet pit and dry pit.

8.3.1.1 Wet pit pump station

In wet pit system, the pump is either submerged underwater connected with a drive shaft to an overhead electrical motor or the submerged pump is directly coupled with submersible motor as shown in Fig 8.1.

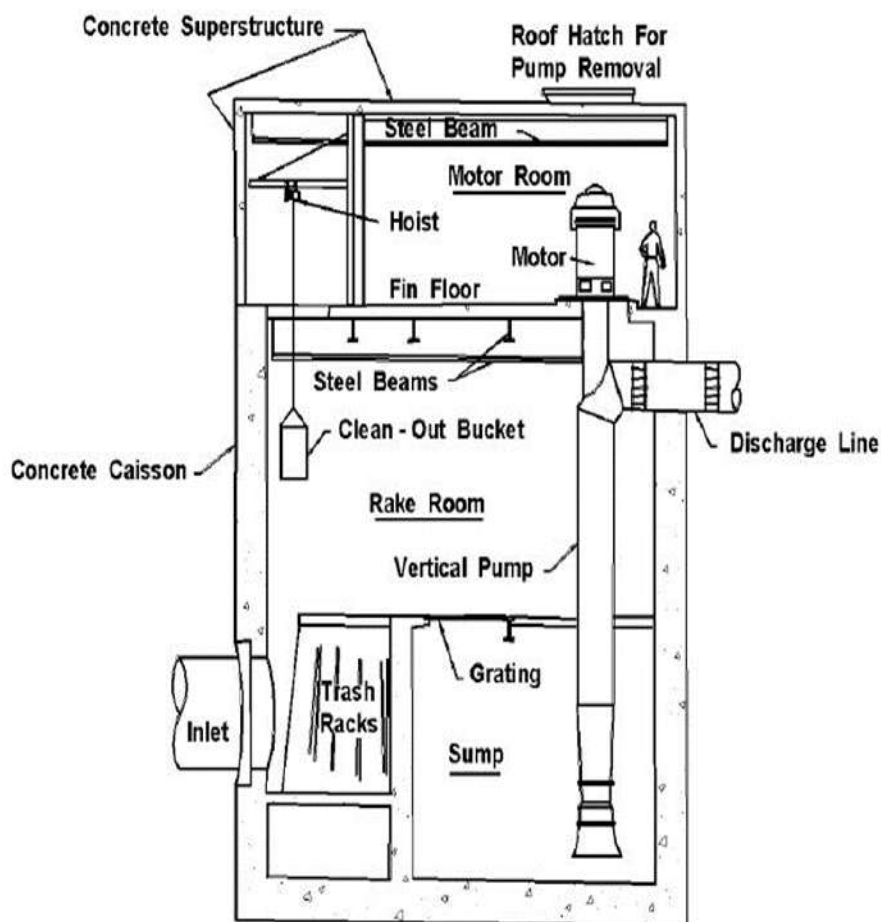

Figure 8.1: Wet Pit Pump Station with vertical turbine pump

8.3.1.2 Dry pit pump station

In dry pit system, the horizontal centrifugal pump directly coupled with the motor is installed on the floor of the dry pit with its suction pipe connected to the sump as shown in figure 8.2.

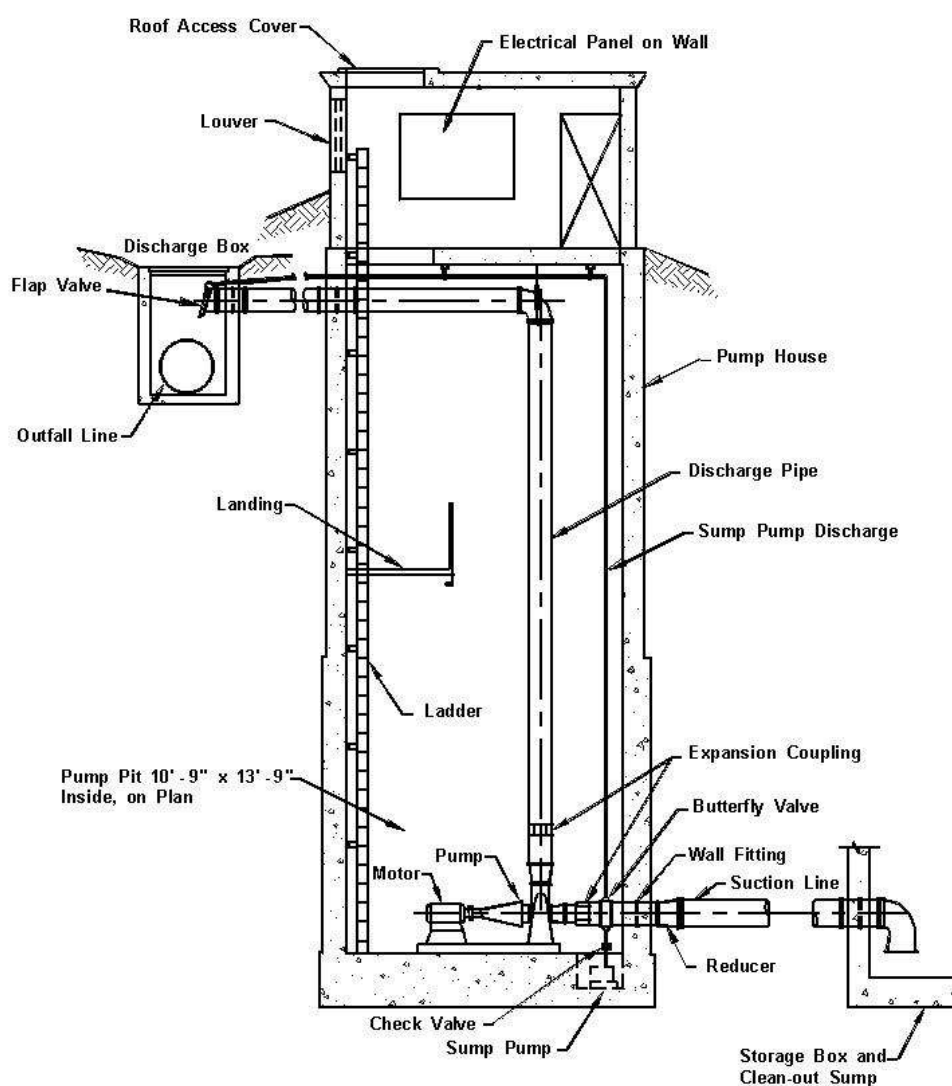

Figure 8. 2: Dry Pit Pump Station with horizontal centrifugal pump

8.3.1.3 Trash Screens

Trash screen should be provided at the entrance to wet pit if large debris is anticipated in the incoming storm water. For storm water pumping station simple steel bar screens are adequate. Usually, bar screens are inclined with bar spacing approximately 58 mm. Constructing the screen in modules facilitate removal for maintenance. If the screen is relatively small an emergency overflow should be provided against clogging and subsequent surcharging the collection system.

In case a substantial amount of sediments are anticipated a catch basin may be provided to settle out the solids.

8.3.2 Choice of Pump Type

The choice of pump type may be considered from the following type of centrifugal pumps that are commonly used in storm water pumping in accordance with the criteria of requirement.

1) Axial flow pump

Axial pumps deliver water parallel to the pump axis and driveshaft. They are generally used for low head and high discharge application. These pumps cannot handle debris because the propeller may be damaged if they strike large and hard object.

2) Radial flow pumps

Radial flow pumps use centrifugal force to deliver water. They can handle a wide range of head and discharge, the best for high head applications. They can handle debris quite well. A single vane non-clog impeller handles debris the best as it provides largest impeller opening.

3) Mixed flow pumps

Mixed flow pumps are similar to axial flow pumps except that they create pressure and velocity to liquids by the centrifugal force of impellers and the lifting force of vanes and thus they are a combination of the above two types. They are suitable for intermediate head and discharge application with better ease in debris handling.

All pumps can be driven either with directly coupled or through a driving shaft with electrical motors or engines. In case of submersible pumps, submersible electrical motor is coupled with the pumps submerged under storm water. Submersible pumps have advantages in simplifying the design, construction maintenance, and thereby reducing the cost of the pump station.

8.3.3 Design of wet pit

When automatic controls and variable discharge pump are installed, the wet well should have storage of 5 min detention of minimum inflow within the wet well. In the absence of such control and variable discharge pump, the wet well should have a storage of a minimum cycle time of peak flow or should have storage from 10 min to 15 min of incoming peak flow calculated by the following formula:

$$V = Q \times t \quad (8.1)$$

Where,

V : Effective Volume of wet well in m^3 (Volume of the wet well below the invert level of storm water drains)

Q : Peak discharge in m^3/min

t : Cycle time in minutes

However, the minimum allowable cycle time (t) is designated by the pump manufacturer based on electric motor size.

It is recommended to provide the same size of duty pump sets capable of managing maximum and minimum storm flows for ease in operation & maintenance. The designer may decide the pumping capacity in accordance with the above recommendations by trial. The standby units may be provided with minimum 50 % of the duty pump units.

The internal diameter of the well shall be kept such that a number of submersible pumps coupled with motors or shaft driven installed inside the well may not create mutual interference with each other. The data required as such should be provided by pump manufacturer along with specified submergence depth of pump for functional efficiency.

In case reduced constant discharge is required, dry pit pump station should be used. The pumps should be connected through a suitable penstock with the storage tank, water level sensor viz. float switch, electronic probes, and ultrasonic devices, etc. should be used to control the pumping system.

8.3.4 Design Capacity of storage tank

The rate of pumped discharge of the storm water should be fixed as per peak inflow of storm water. In case attenuation in peak runoff of the catchment to down stream conveyance main or receiving water bodies is required, the storage volume required to detain the surplus water in a storm water tank.

An example has been given herein to reduce the peak flow of $0.62 m^3/sec$ to $0.40 m^3/sec$ by providing a designed capacity of a storage tank.

The capacity of the storm water storage tank to accomplish the reduction of peak flow discharge either to downstream facilities or to receiving water bodies can be achieved by operating the outflow hydrograph over inflow hydrograph for the design rainfall event over watershed contributing to the tank. The estimated storage volume shall be an area of shaded portion (intercepted between outflow hydrograph and the inflow curve as shown in figure 8.3.

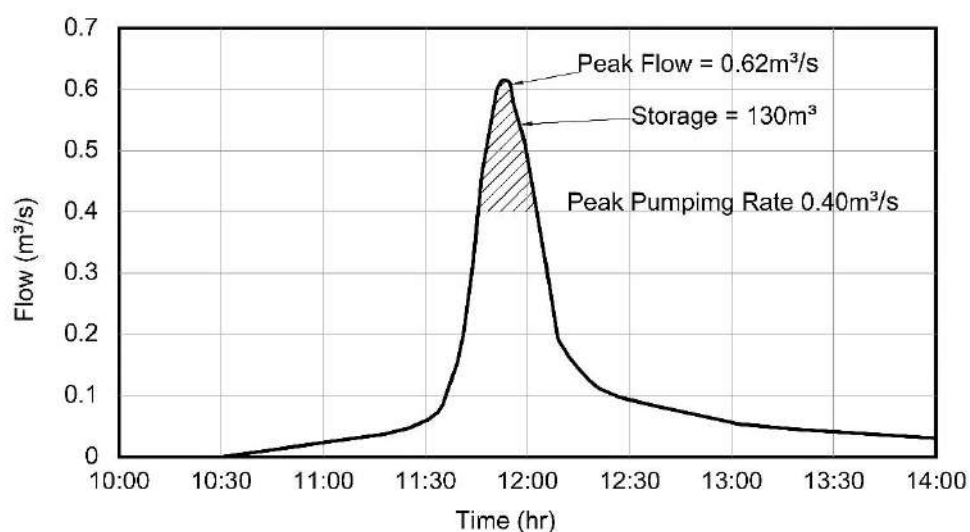

Figure 8. 3: Inflow Hydrograph

By the above graph, it could be easily inferred that the peak flow can be reduced to 0.40 m³/sec by providing a storage tank of 130 m³ capacity.

8.3.5 Pump Characteristic Curves

There are two types of pump curves i.e. system curve and pump curve as described below:

8.3.5.1 System Curve

A plot of the curve for evaluated values of head to be developed by the pump against different values of flow rates is called the system head curve. The total dynamic head comprises total of the following:

$$\text{Total Dynamic Head} = H_s + H_f + H_v + H_l \quad (8.2)$$

Where,

H_s = Static head measured from the liquid level of the sump to the delivery point (m)

H_f = Frictional head in total pipe length from foot valve to delivery end (m)

H_v = Velocity head $\frac{v^2}{2g}$ (m)

H_l = Head loss in fittings and valves (m)

A residual head may also be added if required (m)

8.3.5.2 Pump curve

The pump curve is a plot of curve of pump flow rates versus various heads. Pump curves are supplied by manufacturer of the pump. The point of intersection of pump curve and system curve as shown in figure 8.4, 8.5, 8.6 is called the operating point or design point of the pump.

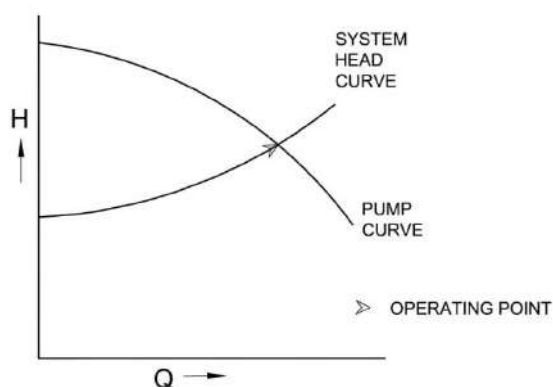

Figure 8. 4: Operating point of the curve

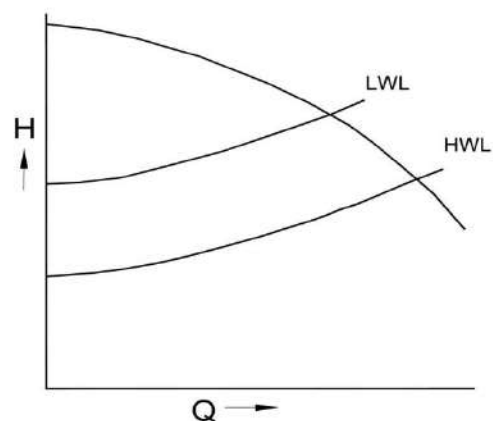

Figure 8. 5: Change in Operating Point of Pump with the change in Water level in Suction Sump

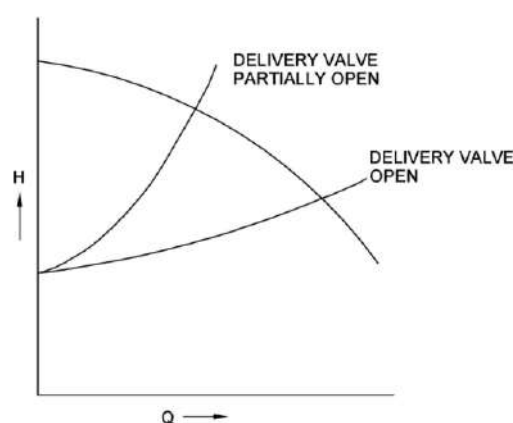

Figure 8. 6: Change in operating point of the pump by operation of delivery

8.3.6 Net Positive Suction Head Required (NPSHr)

The suction lift capacity of a pump depends upon its NPSHr characteristics. The meaning of NPSHr can be explained by considering an installation of a pump working under suction lift as illustrated in Fig 8.7

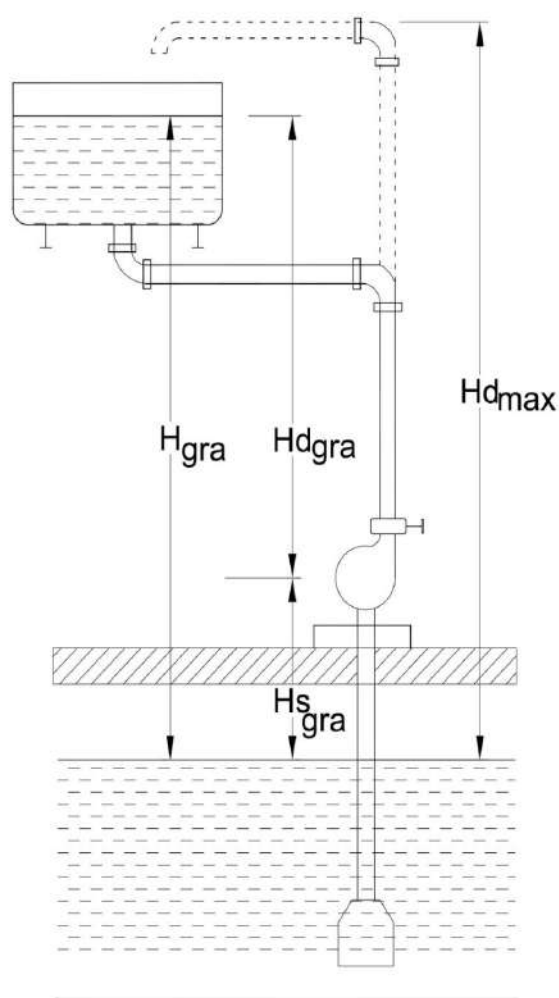

Figure 8.7: Schematic Representation of NPSHr

When a pump, installed as shown is primed and started, it throws away the priming water and has vacuum developed at its suction. The atmospheric pressure acting on the water in the suction sump then pushes the water through the foot valve, into the suction line, raising it up to suction of the pump. While reaching up to the suction of the pump, the energy content of the water, which was one atmosphere when it was pushed through the foot valve would have reduced. This reduction occurs due to partly in overcoming the friction through the foot valve, the piping and the pipe fittings, partly in achieving the kinetic energy appropriate to the velocity in the suction pipe and partly in rising the static suction lift. The energy content left over in the water at the suction face of the pump is thus less than one atmosphere until here the flow is a fairly streamlined flow. But with the impeller rotating at the pump suction, the flow suffers turbulences and shocks and will have to lose more energy in the process. This tax on the energy of the water demanded by the pump, before the pump would impart its energy, is called the NPSHr of the pump.

The NPSHr characteristics of a pump are parabolic, increasing with the flow rate. Pumps of high specific speed have high NPSHr.

8.3.6.1 Vapour Pressure and Cavitation

The energy of the water at the pump suction, even after deducting the NPSHr should be more than the vapour pressure VP, corresponding to the pumping temperature. The vapour pressures in meters of water column (mWC), for water at different temperatures in degrees Celsius are given in Table 8.1.

Table 8. 1: Vapour Pressure of Water

°C	(mWC)
0	0.054
5	0.092
10	0.125
15	0.177
20	0.238
25	0.329
30	0.427
35	0.579
40	0.762
45	1.006
50	1.281

If the energy of the water at the pump suction would be less than the vapour pressure, the water would tend to evaporate. Vapour bubbles so formed will travel entrained in the flow until they collapse. This phenomenon is known as cavitation. In badly devised pumping systems, cavitation can cause extensive damage due to cavitation erosion or due to the vibration and noise associated with the collapsing of the vapour bubbles.

8.3.6.2 Calculating Net Positive Suction Head Available (NPSHa)

To ensure against cavitation, the pumping system has to be so devised that the water at the pump suction will have adequate energy. Providing for this is called as providing adequate Net Positive Suction Head available (NPSHa). The formula for NPSHa hence becomes as follows.

NPSHa= Pressure on the water in the suction sump

$$= P_s - Hf_s - \frac{V_s^2}{2g} - Z_s - V_p \quad (8.3)$$

Where,

P_s : suction pressure

Hf_s : friction losses across the foot valve, piping and pipe fittings

V_s : Velocity at the suction face

Z_s : Potential energy corresponding to the difference between the levels of the pump-centre line and of the water in the suction-pump

V_P : Vapour pressure

While calculating NPSHa, the atmospheric pressure at the site should be considered, as the atmospheric pressure is influenced by the altitude of the place from the mean sea level (MSL). Data on the atmospheric pressure in mWC for different altitudes from MSI, is given in Table 8.2.

Table 8.2: Atmospheric Pressure in mWC at different altitudes above MSL

Altitude above MSL in m	(mWC)
Upto 500	10.3
1000	9.8
1500	9.3
2000	8.8
2500	8.3
3000	7.8
3500	7.3
4000	6.8

8.3.6.3 Guidelines on NPSHr

The NPSHa has to be so provided in the systems that it would be higher than the NPSHr of the pump. The characteristics of the pump's NPSHr are to be obtained from the pump-manufacturers.

8.3.7 Electrical Motors (prime mover)

Generally, either squirrel cage motors or slip ring motors are used as prime movers for pump-drive as per requirement of load i.e. up to 20 B.K.W load squirrel cage motors can be used above to that slip ring motors are used.

8.3.7.1 Motor Rating

Power required at pump shaft to deliver the required quantity of fluid to a specified lift (head, measured in height of water column).

$$\text{B.K.W. (brake Kilo Watt)} = \frac{Q * S * H}{102 * e * E} \quad (8.4)$$

Where,

Q : in L.P.S (pump required discharge)

H : height in meter (lift required)

S : specific gravity of fluid

e : Efficiency of motor

E : Efficiency of pump

A multiplying factor over the computed B. K. W. should be applied as shown in table 8.3 as well as for losses in bearing etc., and additional 3 kW should be added to arrive at the required rating of the motor.

Table 8.3: Multiplying factor for motor rating

Required BKW of the pump	Multiplying factor to decide motor rating
Up to 1.5	1.5
1.5 to 3.7	1.4
3.7 to 7.5	1.3
7.5 to 15	1.2
15 to 75	1.15
Above 75	1.1

8.3.7.2 Voltage rating

General guidance on the standard voltages and corresponding range of motor ratings are given in Table 8.4.

For motor of ratings, 225 kW and above, where high tension (HT) voltages of 3.3 kV, 6.6 kV, and 11 kV can be chosen, the choice should be made by working out relative economics of investments and running costs, taking into consideration cost of transformer, motor, switchgear, cables etc.

Table 8.4: Selection of motor based on supply voltage

Supply	Voltage	Range of Motor rating in KW	
		Minimum	Maximum
Single phase A/C	230 V	0.3	2.5
Three phase A/C	415 V		250
Do	3.3 KV	225	750
Do	6.6 KV	400	
Do	11 KV	600	
D.C	230 V		150

Note: When no minimum is given, very small motors are feasible. When no maximum is given, very large motors are feasible.

Table 8.5: Protective enclosure and environment type of motors

Type	Environment type	Description of environment
Screen protected drip proof SPDP	nil	Indoor, dust-free environment.
Total enclosed	IP44	Indoor dust prone areas
Total enclosed fan cooled TEFC	IP54	Normal outdoor
	IP 55	Outdoor at places of heavy rainfall

8.3.8 Transformer Substation

Normally outdoor substations are provided. However, on considerations of public safety and for protection from exposure to environmental pollution, the substations may be indoors

- i. Lightning arresters
- ii. The gang operated disconnectors (GOD) is provided in an outdoor substation. In indoor substation, circuit breakers are provided. In case of outdoor substations of capacities 1000KVA and above, circuit breakers should be provided in addition to GOD.
- iii. Drop out fuses for small outdoor substations.
- iv. Overhead bus bars and insulators.
- v. Transformer.
- vi. Current transformer and potential transformer for power measurement.
- vii. Current transformers and potential transformers for protection in substations of capacity above 1000 KVA.
- viii. Fencing.
- ix. Earthing

Earthing should be very comprehensive, covering every item in the substation and accordance with IS: 3043.

8.3.8.1 Transformer Rating

a) Estimation of total power consumption

The first step in the transformer rating is to estimate the power consumption for various units of pumping station such as:

- a. Power consumed of working motors

- b. Power consumed by ventilating equipment
- c. Power consumed by automation equipment
- d. Power consumed by lighting
- e. Power consumed by fan etc.

In this manner the total power consumed may be estimated to be 'A' KW, then add 10% for miscellaneous consumptions. Thus, say 'B' KW is the total power required for which transformer is to be rated.

Total power requirement – 'B' KW

Then transformer rating – 'B' KW /0.85 = KVA

Where 0.85 is a power factor

Example 8.1

Total Power consumption = 1000 KW

Hence, transformer KVA required at 0.85 Power Factor and 10% margin

= $1000 \times 1.1/0.85 = 1294$ KVA

Hence, provide the next commercial rating as 1600 KVA

8.3.8.2 Improvement of Power Factor

For improvement of power factor, appropriate capacitors should be provided. Capacitors may be located in the control panel or separately by an automatic power factor correction panel which monitors a bank of capacitors through a power factor sensing relay and appropriate contactors.

8.3.8.3 Lighting

The interior of pump stations shall be provided with sufficient lighting system specially designed to achieve best illumination suited to the station layout. Energy-efficient fluorescent fixtures are preferred. Lighting shall be at adequate levels for routine service inspections and maintenance activities as given in Table 8.6.

Table 8.6: Illumination Levels

S No	Area		Illumination Level (LUX)
1	Sub Station Building	:	250
2	Pump House	:	200
3	Control Room	:	300
4	Transformer Yard	:	50
5	Aerator Operating Platform	:	50
6	Screen & Grit Separator area	:	50
7	Chemical Stores	:	100
8	Centrifuge House	:	150
9	Chlorine Tonner Room	:	150
10	All other indoor areas	:	100
11	Outdoor Plant Area	:	20
12	Roads	:	10

Source: Manual on Water supply and Treatment (1991), CPHEEO

8.3.8.4 Ventilation

Pump stations shall be provided with a separate ventilating system and shall be sized to provide a minimum of 10 air changes per hour. Ventilation systems shall be capable of matching inside air temperature to outside air and shall be automatic. Ventilation shall be accomplished by the introduction of fresh air into the pump station.

8.3.9 Pumping main

A pipeline either long or short when used to transport storm water against gravity under pressure generated by an arrangement of a suitable pumping unit is generally termed as pumping main. The design of such pumping main depends on the following factors:

- a. Quantity of design flow
- b. Available pressure or head
- c. Losses of friction in pipe and fittings
- d. Allowable velocity of flow
- e. Quality of fluid
- f. Material of pipe

Process design for sizing the pipe diameter is given as follows:

- a. Determine the design flow rate in cum/hr
- b. Determine the total head in m

- c. Select pipe material capable of withstanding hydraulic design pressure
- d. Choose allowable self-cleansing velocity not less than 0.6m/sec and not more than 1.4m/sec
- e. Use Hazen – William formula or Darcy Weisbach formula as given in the following section
- f. Keep friction loss between 0.9 m and 1.2 m per 1000.0m to maintain prescribed velocities as given in sl(d)
- g. Test the pumping main against surge pressure and provide necessary protection if required.

In case a pumping main is considerably long involving heavy investment attempt should be made to design an economical size of the pipe. The design of economical size of pipe (diameter) is based on the following parameters:

- a) A design horizon of 30 years
- b) Different type of pipe materials conducive to site conditions
- c) Different sizes of pipes against different hydraulic grades which are considered for a given quantity of storm water to be pumped
- d) The useful service life of different materials and their relative costs as laid in position
- e) The duty, capacity and installed cost of pump sets required against the corresponding sizes of pipelines under consideration
- f) Recurring costs like energy cost and annual maintenance cost of corresponding sizes of pipelines under consideration
- g) The prevailing rate of interest

The process of computation may be referred to Manual on Water supply and Treatment (1991), a publication of MoHUA, Govt. of India.

8.3.9.1 Friction flow formula to size Pumping Mains

Darcy Weisbach and Hazen Williams formulae are given for pressure-pipe frictional assessment.

$$h_f = \frac{fLv^2}{2gD} \quad (8.5)$$

Where,

h_f : Head loss in pipe due to friction (m)

f : Darcy Weisbach friction factor can be found from Moody's diagram given in Appendix A 5.6.

L : length in pipe (m)

D : Diameter of pipe (m)

V : Velocity of flow in pipe m/sec

G : Acceleration due to gravity (m/sec²)

Hazen William Formula

$$Q = 1.292 \times 10^{-5} \times C \times d^{2.63} \times S^{0.54} \quad (8.6)$$

$$V = 4.567 \times 10^{-3} \times C \times d^{0.63} \times S^{0.54} \quad (8.7)$$

Where,

Q : Discharge in m³/hr

d : pipe diameter in mm

S : Hydraulic Slope

C : Hazen William Coefficient as per Table 8.7

A chart for Hazen William's formula is in Appendix A 5.5 (C) and A 5.5 (D) for stated ranges of discharges.

Table 8.7: Values of Roughness coefficient, C, in Hazen-Williams formula

Material	Hazen-Williams C
New Pipes	
Cast Iron	130-100
Concrete(RCC&*PCC with S/S	150-120
Concrete-lined Galvanized iron	120
Plastic	150-120
Steel welded joints lined with cement or bituminous enamel	150-120
Asbestos cement	150- 120
Welded Steel	140- 100

Source: Manual on Sewerage and Sewage Treatment Systems, CPHEEO

However, the selection of pipe materials in order to minimize the head losses in pipes should be considered. Besides, slime and sediment deposits on internal surfaces of the pipes do affect the smoothness of internal surfaces of the pipes consequently contributing to frictional losses. Metal pipes are generally provided with a lining of smooth material such as PVC etc. to reduce the losses. Other factors such as pipe

joints, manholes, branch pipes, bends, elbows, sudden enlargement and reduction in pipe sizes, inlets, outlets etc. shall also contribute to losses that need to be computed in system design. There will be pressure losses in fittings which shall be accounted for as in Table 8.8 by multiplying the factor with the velocity head.

Table 8. 8: Friction factor for fittings in pumping mains

No.	Types of Fittings	Factor
1.	Sudden contraction	0.5
2.	Entrance shape well rounded	0.5
3.	Elbow 90 degrees	1.0
4.	Elbow 45 degrees	0.75
5.	Elbow 22 degrees	0.5
6.	Tee 90 degrees	1.5
7.	Tee in a straight pipe	0.3
8.	Gate valve open	0.4
9.	Valve with reducer and increaser	0.5
10.	Globe valve	10.0
11.	Angle	5.0
12.	Swing Check	2.5
13.	Venturimeter	0.3
14.	Orifice	1.0

Source: Manual on Sewerage and Sewage Treatment Systems, CPHEEO

8.4 Flow Measurement

Measurement of flow in storm water channels and conduits are generally measured either at pumping point, outfall location or at any selected points of interest, etc. Different methods of flow measurement are given as follows:

8.4.1 Measurement of flow in open Channels

8.4.1.1 Rectangular Notches

The installation requirements, specifications, head measurements, head limits, and accuracy will be the same as for triangular notches. The width of notch should be at least 150 mm.

There are two types of rectangular notches viz. (i) with end contractions and (ii) without end contractions.

(i) With End Contractions

The contraction from either side of the channel to the side of the notch should be greater than 0.1 m.

The discharge (m^3/s) through a rectangular notch with end contractions is given by the equations:

$$Q = \frac{2}{3} C_e \sqrt{2g} b_e H^{1.5} \quad (8.8)$$

Where,

b_e : Effective width = Actual width of the notch + k (value of k being 2.5 mm, 3 mm and 4 mm for b/B ranges of upto 0.4, 0.4 to 0.6 and 0.6 to 0.8 respectively)

b/B : Ratio of the width of the notch to the width of the channel

H : Effective head = actual head measured (h) + 1 mm

g : Acceleration due to gravity (9.806 m/s^2)

C_e : varies from 0.58 to 0.70 for values of b/B from 0 to 0.8

(ii) Without End Contractions

The discharge (m^3/s) through a rectangular notch without end contractions is given by the following expression:

$$Q = \frac{2}{3} C_e \sqrt{2g} b H^{1.5} \quad (8.9)$$

Where,

b : Width of the notch (m)

H : Effective head = actual/measured head (h) + 1.2 mm

C_e : $0.602 + 0.075 h/p$

Where,

P : Height of the bottom of the notch from the bed of the channel

8.4.2 Measurement of flow in Closed Conduits

8.4.2.1 Differential Pressure Devices

The venturi, orifices and nozzles are used specifically for closed conduits. They shall have minimum length of $5D$ on the upstream side and $2D$ on the downstream side of the device (where D is the diameter of upstream pipe).

8.4.2.1.1 Venturi Meters

Venturi meters provide a most dependable relation of differential pressure to velocity through the ranges of flow required by engineering practice and return of at least 85% of the velocity head when constructed in accordance with standard proportions of extreme importance is the establishment of the accuracy of their coefficient, which give them preference as a means for producing suitable velocity heads.

Standard venture meters usually are constructed with piezometer rings at the main and throat section which are connected to the interior surface of the meters. Alternatively the pressure chambers could be omitted and pressure taps at main and throat are provided. Each of these taps is equipped with a manually operated cleaning valve.

Where fluids contain sediment or carry substance that may tend to clog the piezometer opening, clear water flushing disconnectors and cleaning valves at both main and throat sections are included.

Under special conditions, a venture with a circular inlet and outlet an elliptical throat section, providing a flat invert as well as a flat top for the entire length of the tube can be employed. The flat invert is self-scouring and prevents the accumulation of grit or other solids under low flow conditions while the flat top prevents the trapping and accumulation of air and gases, which under some conditions could adversely affect the accuracy of the instrument reading.

Discharge through a venturi meter is given by the expression

$$\text{Discharge } Q = K \frac{a_1 a_2}{\sqrt{a_1^2 - a_2^2}} \sqrt{2gh} \quad (8.10)$$

Where,

a_1 : Area of the pipe in m^2

a_2 : Area of the throat section in m^2

h : Sum of the difference between pressure heads and potential heads at the inlet and throat sections, in m

The coefficient K varies 0.95 to 0.98

The ratio of the diameter at the throat to the diameter at normal inlet section varies from $\frac{1}{4}$ to $\frac{3}{4}$ and the usual ratio is $\frac{1}{2}$. The smaller ratio gives increased accuracy of gauge reading but is accompanied by higher fractional losses and low pressure at the throat which could lead to cavitation. The angles of convergence and divergence in a venturi meter are 20° and 5° respectively

There are other electronic devices that are widely used these days for measurement of flow such as Magnetic Flow Meters and Ultrasonic Flow Meters, which are readily available with the manufacturers of these meters.

8.5 Storm water Storage Pond/Basins

The primary function of storm water storage pond is either to store the storm water and gradually release through a controlled mechanism to receiving water bodies, conveyance system, or completely consumed via infiltration and evaporation. There are two types of storm water storage tank, as described below.

8.5.1 Detention ponds/Basin

Detention facilities provide temporary storage of storm water that is released through an outlet that controls flows to pre-set levels. Detention facilities typically flatten and spread the inflow hydrograph, lowering the peak to the desired flow rate. It is generally planned to limit the peak outflow rate to the pre-development stage of the same catchment for a specific range of flood frequencies.

8.5.2 Retention ponds/Basin

Retention ponds may also be called an extended detention pond as defined above as all the stored storm water is absorbed through infiltration and evaporation over a long period of time. Nevertheless, the stored water may be used if need be for water supply and recreational purposes, etc. The pervious bottom should be provided in these tanks to ensure sufficient infiltration capability to empty the pond within a reasonable time. This is discussed in the rainwater harvesting section.

8.5.2.1 Site Selection

Proximity to the flood-prone area may be a primary consideration while selecting site for detention basin. The nearer the site to such areas, the larger the tributary areas that could be controlled by the site.

8.5.2.2 Adequacy of the site size

Land should be available of adequate size as determined by areal extent of the site such that required volume of water could be stored temporarily on-site.

8.5.2.3 Topographic consideration

Topographic configuration should permit gravity-driven inflow and outflow from the detention basin, which is the most desirable situation in locating the site for a detention basin.

8.5.2.4 Access to the site

Access must be provided for inspection and maintenance either from adjacent publically owned land or through privately owned land under access easement provision.

8.5.3 Design of storm water Storage Pond/Basin

The final design computation for detention basin/pond requires three curves:

- a. An inflow hydrograph for design rainfall events occurring over the catchment contributing to the basin/pond.
- b. A stage versus storage curve
- c. A stage versus discharge curve

A preliminary estimate of the storage required to reduce the peak flow within desired limits to be released to downstream facilities or receiving bodies of water should first be computed by the method described as follows:

1. Obtain an inflow hydrograph for the design rainfall event occurring over the catchment contributing to the pond
2. Develop an approximate outflow hydrograph either by a straight line or by sketching an assumed outflow of the same time base as that of inflow hydrograph. Peak flow should be kept below inflow hydrograph peak to the desired level.
3. Operate the above outflow hydrograph by superimposing on the inflow hydrograph as shown in figure 8.8
4. Area of an intercepted portion (shaded) within two hydrographs in figure 8.9 shall give the initial storage requirement of the detention pond.

8.5.4 Optimization of Detention Tank/ Basin Capacity

To optimize the tank capacity 'design storm' draining the given catchment are routed through the basin to determine the maximum storage volume and water level in the basin corresponding to the maximum allowable outflow rate. A number of trials may have to be worked out to maximize tank volume. However manual calculations for the number of hydrographs that need to be estimated and routed through the tank will be too tedious, complex and time-consuming. A suitable computer model may be used to perform these calculations with ease and promptness.

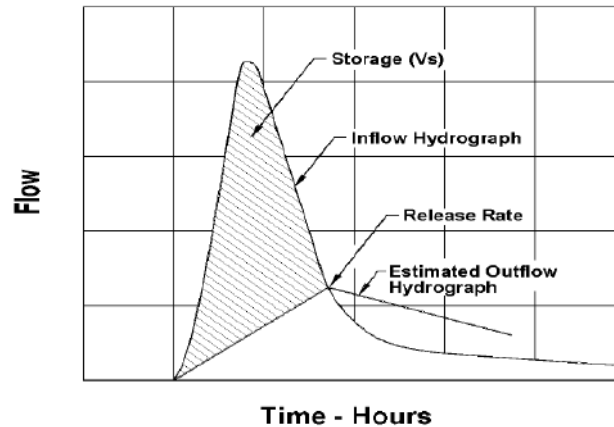

Figure 8. 8: Inflow and Outflow Hydrograph

8.5.5 Basin outlet

Suitable outlets are provided for the planned release of water from a detention basin. A stage-discharge relation curve is developed for full range of flows that the outlet structure would experience. Weir or orifice is typically provided as outlet device consistent with high and low rate of discharge, respectively. These outlet arrangements are generally housed in a riser structure connected to a single outlet conduit that passes through the basin embankment and discharges to the point of interest. Care should be taken to ensure that the stage-discharge relationship adequately reflects the range of different flow regimes that the structure will operate upon.

CHAPTER 9: INTEGRATION OF RAINWATER HARVESTING IN STORM WATER DRAINAGE DESIGN

9.1 General

The conventional approach of storm water drainage systems design is considered to be uneconomical and infeasible in many cities due to its current pace of sprawling. The ever increasing urban runoff primarily due to growing size of urban areas, rampant paving of urban spaces and global warming induced climate change have posed new challenges before city authorities. In order to address these issues and to control the runoff at source itself, integrating rainwater harvesting (RWH) systems in storm water drainage systems design is increasingly being adopted.

9.2 Integration of rainwater harvesting & recharge systems with storm water drainage design

With increase in number of large urban sprawling, the problems due to frequent flooding and consequent damages of life and property have posed a difficult challenge before city managers. Often due to huge cost involvement and lack of space to accommodate wide storm water drain sections, city planners and engineers are emphasizing integration of rainwater harvesting & recharge systems in storm water drainage systems design. The various options / techniques for rainwater harvesting and recharge, suitable for integration with storm water drainage system design, are listed below:

9.3 Rainwater harvesting techniques

To minimize the quantity of storm runoff reaching to the storm water drains, a certain quantity of storm water can be stored / percolated by introducing suitable techniques as below:

- I. In-situ storage / percolation within or around premises
- II. Storage of runoff in nearby pond / water tank
- III. Percolation of storm water inside / outside the drains along its stretch
- IV. Spreading water for recharge in low lying areas and parks / gardens etc.
- V. Disposal to reservoir / water body

9.3.1 In-situ storage / percolation

Rain water can be either stored within a building premises or it can be diverted to a suitable place for use as explained below:

9.3.1.1 Roof top rainwater collection potential

Rain water from the roof can be safely collected through rain water pipe either in a constructed underground tank / reservoir for domestic use or can be percolated / recharged in the ground water.

In a city having annual rainfall of 1000 mm, a roof top of an area of 100 sqm has potential to collect rain water to the tune of 1,00,000 ltr ($100 \text{ m}^2 * 1 \text{ m}$) in a given year. At rate of 100 lpcd consumption per person for a family of 4, the water can be sufficient to meet various domestic requirements for $(1,00,000 / 400 = 250 \text{ days})$. However, it is to be stressed that before the onset of the monsoon season, the roof surface should be properly cleaned.

In places where there are constraints in storing the rainwater, the same can be safely recharged into the ground through various recharge techniques like percolation pits, abandoned tube wells etc. Even partial storing / recharging of rain water will go a long way in reducing peak runoff in storm water drains, thereby, reducing the incidences of flooding in low lying area. Same approach can be followed on community basis as well. However, due care should be taken to ensure that polluted water is not allowed to enter into the system and the system is periodically cleaned to function as per design requirements.

A typical roof top rainwater harvesting system is shown in Fig 9.1.

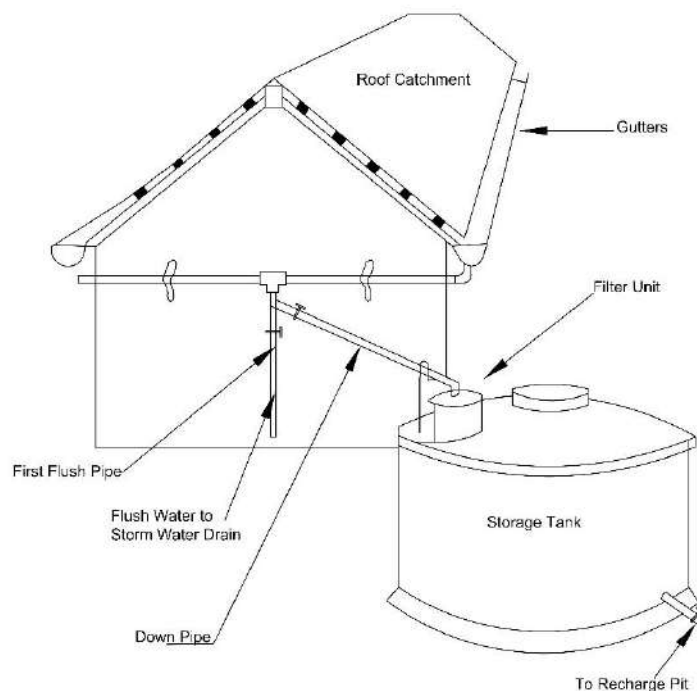

Figure 9.1: Typical rooftop rainwater harvesting system

Filter unit for filtration of the rain water is given in figure 9.2.

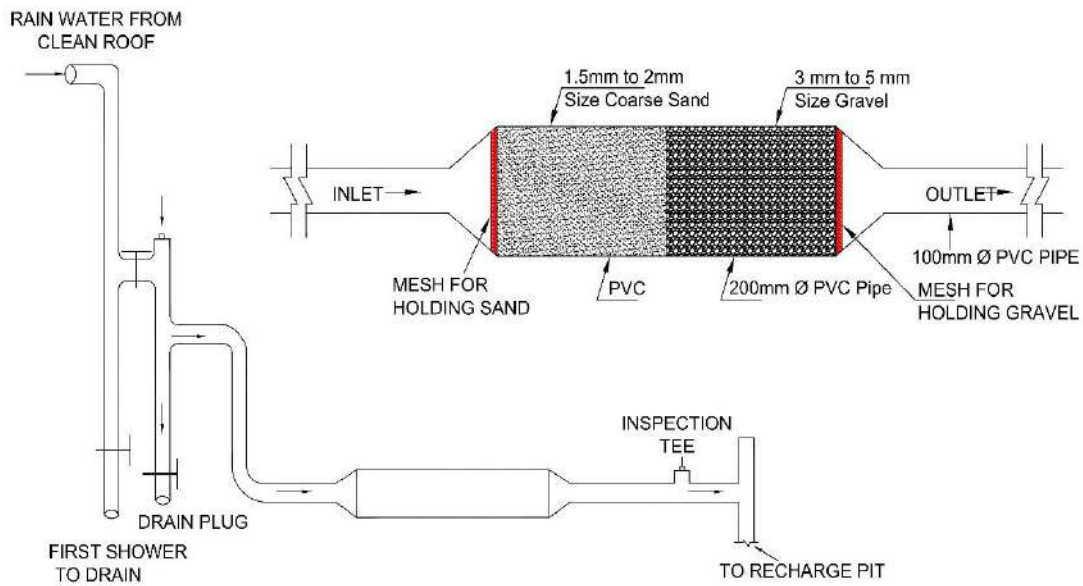

Figure 9.2: Filter unit

For better performance, the filter should be periodically cleaned and properly maintained. For further details, Manuals of CGWB and CPWD may be referred. The Central Ground Water Board has prepared a ready reckoner to serve for estimating water from roof tops (m^3) and is shown in Table 9.1.

Fig 9.1 shows a typical roof catchment, the gutters fitted at the eaves, down spout connected with the gutter at upper end and with rain water pipe at the lower end. The rain water pipe is fixed on the wall by clamps and joins the storage tank on the ground. The various components of RWH are briefly described below.

1. **Roof Surface:** The roof surface is the area which can be either flat or sloping. This receives the rainfall and from which the collected rainwater is to be harvested.
2. **Gutters:** These are made of different materials such galvanized iron sheet folded to desired shape & size. Semi-circular gutters are prepared from PVC material. Gutters are made 10 to 15 percent over sized according to flow during highest intensity rainfall.
3. **Conduits:** These are pipelines or drain pipes that carry rain water from roof catchments to harvesting system.
4. **Storage tanks:** Such tanks of various sizes to accommodate harvested rain from roof tops can be of varied sizes and placed above or below ground depending upon availability of space. Reinforced cement concrete (RCC) and polyethylene and metal sheets are commonly used for preparing various shapes & sizes of storage tanks.

Table 9.1: Availability of Rainwater through Roof Top Rainwater Harvesting

Roof top area (Sq.m.)	Rainfall (mm)												
	100	200	300	400	500	600	800	1000	1200	1400	1600	1800	2000
Harvested Water from Roof Top (cum)													
20	1.6	3.2	4.8	6.4	8	9.6	12.8	16	19.2	22.4	25.6	28.8	32
30	2.4	4.8	7.2	9.6	12	14.4	19.2	24	28.8	33.6	38.4	43.2	48
40	3.2	6.4	9.6	12.8	16	19.2	25.6	32	38.4	44.8	51.2	57.6	64
50	4	8	12	16	20	24	32	40	48	56	64	72	80
60	4.8	9.6	14.4	19.2	24	28.8	38.4	48	57.6	67.2	76.8	86.4	96
70	5.6	11.2	16.8	22.4	28	33.6	44.8	56	67.2	78.4	89.6	100.8	112
80	6.4	12.8	19.2	25.6	32	38.4	51.2	64	76.8	89.6	102.4	115.2	128
90	7.2	14.4	21.6	28.8	36	43.2	57.6	72	86.4	100.8	115.2	129.6	144
100	8	16	24	32	40	48	64	80	96	112	128	144	160
150	12	24	36	48	60	72	96	120	144	168	192	216	240
200	16	32	48	64	80	96	128	160	192	224	256	288	320
250	20	40	60	80	100	120	160	200	240	280	320	360	400
300	24	48	72	96	120	144	192	240	288	336	384	432	480
400	32	64	96	128	160	192	256	320	384	448	512	576	640
500	40	80	120	160	200	240	320	400	480	560	640	720	800
1000	80	160	240	320	400	480	640	800	960	1120	1280	1440	1600
2000	160	320	480	640	800	960	1280	1600	1920	2240	2560	2880	3200
3000	240	480	720	960	1200	1440	1920	2400	2880	3360	3840	4320	4800

Source: Manual on Artificial Recharge of Ground Water, 2007

The design guidelines of RWH system is as follows:

a) Conveyance System

Conveyance system includes gutters and downpipes ending at common collection chamber. Following recommendations should be followed:

- i. Gutters are used to convey water from the roof to pipes to the storage tank or cistern.
- ii. Use an expansion joint if a straight run of gutter exceeds 20 m.
- iii. Keep the front of the gutter 15 mm lower than the back.
- iv. Provide a minimum gutter slope of 1:200.
- v. Gutter should be a minimum of 26 gauge galvanized iron or 22 gauge Aluminum.
- vi. Downspout should provide 6 square cm of opening for every 10 square m of roof area.
- vii. The maximum run of gutter for one downpipe is 15 m.

b) Size of Rain Water Pipes for Roof drainage

The broad idea about the particular diameter of pipe which will be required to cater the certain roof surface area for given average rate of rainfall in mm/hr is shown in Table 9.2.

Table 9. 2: Sizing Rain Water pipes for Roof Surface area drainage

Diameter pipe(mm)	Average rate of rainfall (mm/hr)					
	50	75	100	125	150	200
	Roof area (m ²)					
50	13.4	8.9	6.6	5.3	4.4	3.3
65	24.1	16.0	12.0	9.6	8.0	6.0
75	40.8	27.0	20.4	16.3	13.6	10.2
100	85.4	57.0	42.7	34.2	28.5	21.3
125	-	-	80.5	64.3	53.5	40.0
150	-	-	-	-	83.6	62.7

Source: CPWD Rain water Harvesting Manual

The storage system ensures water for continuous supply even during dry periods. The storage tank is designed on the basis of a mechanism which store water during excessive raining and thus facilitating the use of the stored water during dry period.

The storage tanks are designed based on requirements of water, average annual rainfall, and size of catchment. Designing the storage tank capacity for dry period is calculated as follows:

- | | | |
|-------|---|----------------------|
| (i) | Area of rooftop | : 100 m ² |
| (ii) | Average rainfall | : 1000 mm |
| (iii) | Coefficient of runoff for concrete roof | : 0.80 |

- **Tank capacity for 245 scarcity days** : $100 \text{ sqm} \times 1 \text{ m} \times 0.80 = 80,000 \text{ ltrs.}$
- **Drinking water for family of 5 members** : $10 \text{ lpcd} \times 5 \text{ members} \times 245 \text{ days} = 12,250 \text{ ltrs}$
- **Add safety factor of 20 %** : $1.20 \times 12,250 = 14,700 \text{ litres.}$

Hence, a rectangular tank with a depth of 2.5 m, length = 2.5 m, breadth of 2.5 m or as per the design.

Harvested rooftop rainwater can be used for domestic purposes. However, in water-scarce areas, that can be used for drinking purposes also after proper treatment and disinfection to be decided based on the quality of raw water and the period of its storage in the tank. However, since this is related to safety of public health before using for drinking purposes as a last resort, the suitable boiling / treating through RO process/ disinfection of storm water to be carried out as per city government guidelines / National Manual on water supply and treatment.

9.3.1.2 Percolation of runoff into ground

Rainwater collected from roof catchment can also be recharged to the aquifer through suitable structures such as Percolation pits, percolation trenches, and recharge wells, etc.

9.3.1.2.1 Percolation pits

This method is suitable where a permeable stratum is available at shallow depth. It is adopted for buildings having roof area up to 100 sqm. Recharge pit of any shape is constructed generally 1-2 m wide and 2-3 m deep. The pit is filled with boulders, gravel, and sand for filtration of rainwater. Water entering into RWH structure should be silt free. Top layer of sand of filter should be cleaned periodically for better ingress of rainwater into the subsoil. Details are shown in Figure 9.3.

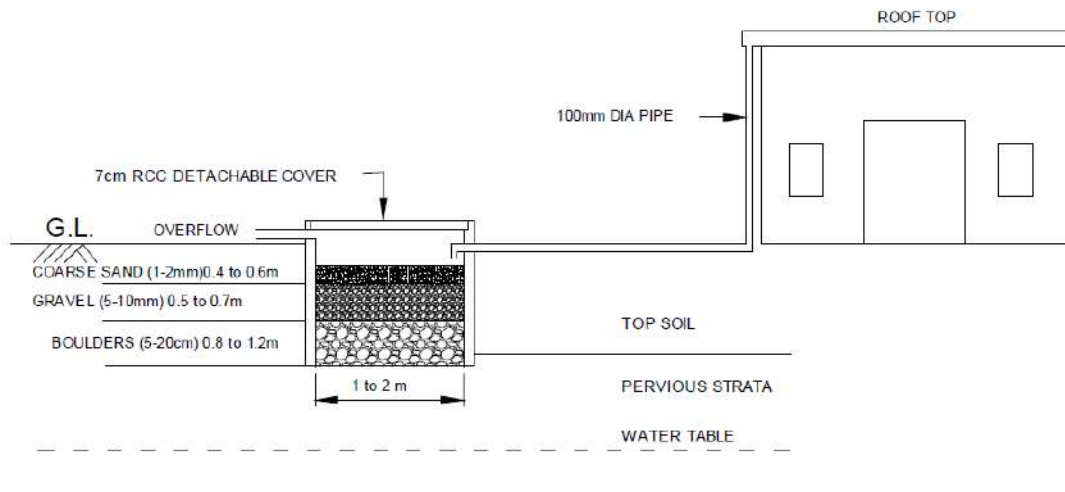

Figure 9.3: Percolation Pit

9.3.1.2.2 Percolation trenches

This method is used where permeable strata are available at shallow depth. It is suitable for buildings having rooftop area between 200 & 300 sqm. In this method, trench of 0.5-1.0 m wide, 1-1.5 m deep and of adequate length depending upon rooftop area and soil/subsoil characteristics should be constructed and filled with boulders, gravels and sand as shown in Figure 9.4. Cleaning of filter media should be done periodically.

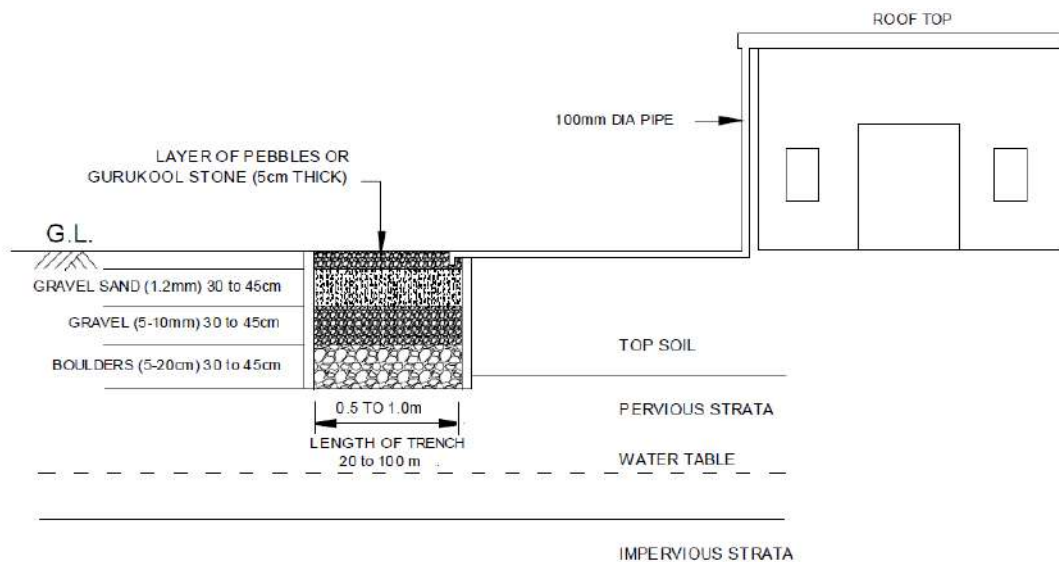

Figure 9.4: Percolation Trench

9.3.1.2.3 Recharge wells

In this method, a dry/unused dug well can be used as a recharge structure. It is suitable for buildings having a rooftop area of more than 100 sqm. Recharge water is guided through a pipe of 100 mm to the bottom of the well, as shown in Figure 9.5. Well cleaning and desilting are imperative before using it. Recharge water guided should be silt free, otherwise filter should be provided as shown in Figure 9.5. Well should be cleaned periodically and chlorinated to control bacteriological contamination.

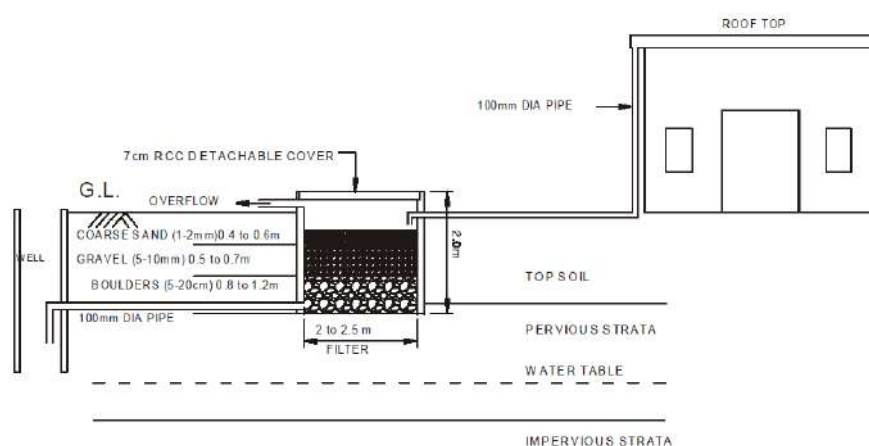

Figure 9.5: Recharge Wells

9.3.2 Storage of runoff in nearby percolation pond / water tank

Percolation tank is an artificially created surface water body, submerging in its reservoir a highly permeable land, so that accumulated runoff is made to percolate and recharge the groundwater storage. Depending on requirement, it is possible to have more than one percolation tank in a catchment if sufficient surplus runoff is available and the site characteristics favour artificial recharge through such structures. In such situations, each tank of the group takes a share of runoff of the whole catchment above it, which can be classified into two categories, i.e. free catchment and combined catchment as defined below:

- (i) 'Free catchment', which is the catchment area that only drains into the tank under consideration and
- (ii) 'Combined catchment', which is the area of the whole catchment above the tank.

The difference between the combined and free catchment gives the area of the catchment intercepted by the tanks located upstream of any tank. Each tank will

receive the whole runoff from its free catchment, but from the remainder of its catchment it will receive only the balance runoff that remains after the upper tanks have been filled.

9.3.3 Percolation of storm water inside/outside the drains along its stretch

The existing drains in urban area are attractive infrastructure facilities for arresting surplus urban run-off, which runs waste in monsoon period. Hydraulics of groundwater recharge through surface drains should be evaluated for which input parameters such as recharge rate, free flow, and detained flow can be used in the computation of total volume recharged. Recharge rates can be computed at different depths of flow in the drain. Accordingly volume of water recharged and rise in groundwater table can be assessed at, for different rainfall events. The recharge rate through surface drains increases with increase in depth of flow in the drain and volume of water recharged under detained flow conditions.

Rainwater collection model through storm water drain in urban areas is depicted in Figure 9.6.



Figure 9.6: Rain water collection through storm water drains

For percolation of storm water runoff inside drains, wherever feasible, the bottom of the channel should be kept pervious according to approved design and capacity of storm water runoff to be carried duly accounting for constraints like land availability, etc.

9.3.4 Spreading water for recharge in low lying areas and park/gardens etc.

This technique is ideal for lands adjoining rivers or irrigation canals in which water levels remain deep even after monsoons and where sufficient non-committed surface water supplies are available. The schematics of a typical flooding system are shown

in Fig 9.7. To ensure proper contact time and water spread, embankments are provided on two sides to guide the unutilized surface water to a return canal to carry the excess water to the stream or canal. Flooding method helps reduce the evaporation losses from the surface water system, is the least expensive of all artificial recharge methods available and has very low maintenance costs.



Figure 9. 7: Water spreading in low lying area

Note: The detailed design criteria is elaborated in detail in ‘Manual on Artificial Recharge of Ground Water’, published by CGWB. The same can be accessed at www.cpheeo.gov.in.

9.3.5 Disposal to water body

After proper sedimentation, runoff from urban catchment should be disposed to the natural water bodies. The aerial extent of the water bodies and its capacity should be investigated to assess the requirement of the quantity of runoff from the catchment.

9.4 Precaution to be considered for harvesting of storm water

The storm water flow from a combined sewer shall never be taken up for recharge into the ground. Similarly, there would be situations wherein the sewage is getting mixed even in the drains meant exclusively for storm water and in such cases also the recharge of this sewage mixed with storm water shall be avoided unless or otherwise this is treated prior to a level fit for recharge. This shall be meticulously followed to avoid causing pollution. However, CPCB standards for river water quality is expected for storm water drains.

9.5 Pollution of Storm Water and its Treatment

The storm water runoff from the urban areas during the first rains will come into contact with the pollution in the storm water drains, parking lots, etc. which have accumulated till that time. These can be night soil, urine, vegetable rejects, food rejects, dead insects, rats, etc. and decaying papers, etc. in the drains and chemical contaminants

in the parking lot, etc. Once these are washed into the watercourses, they pollute the same and may start water-borne diseases like Cholera, Typhoid, Jaundice, etc. in the waters. Sources of contaminants in urban storm water runoff are given in Table 9.3.

Table 9.3: Sources of Contaminants in Urban Storm Water Runoff

Contaminant	Contaminant Sources
Sediment and Floatables	Streets, lawns, driveways, roads, construction activities, atmospheric deposition, drainage channel erosion
Pesticides and Herbicides	Residential lawns and gardens, roadsides, utility right-of-ways, commercial and industrial landscaped areas, soil wash-off
Organic Materials	Residential lawns and gardens, commercial landscaping, animal wastes
Metals	Automobiles, bridges, atmospheric deposition, industrial areas, soil erosion, corroding metal surfaces, combustion processes
Oil and Grease/ Hydrocarbons	Roads, driveways, parking lots, vehicle maintenance areas, gas stations. illicit dumping to storm drains
Bacteria and Viruses	Lawns, roads, leaky sanitary sewer lines, sanitary sewer cross-connections, animal waste, septic systems
Nitrogen and Phosphorus	Lawn fertilizers, atmospheric deposition. automobile exhaust, soil erosion, animal waste, detergents

The US EPA's Nationwide Urban Runoff Program (NURP) carried out a comprehensive study of urban runoff between 1978 and 1983 to examine the characteristics of urban runoff and similarities or differences between urban land uses, the extent to which urban runoff is a significant contributor to water quality problems nationwide, and the performance characteristics and effectiveness of management practices to control pollution loads from urban runoff. The sampling was conducted for 28 NURP projects which included 81 specific sites and more than 2,300 separate storm events.

Median event mean concentrations (EMCs) for the ten general NURP pollutants for various urban land use categories are presented in Table 9.4. However, it is to be emphasized that Table 9.4, along with their values are mentioned for presenting the context, and in an Indian context the values would be much higher. This is due to the fact that the storm water drains in that country are not abused by people for night soil, urine, waste food, etc. but in our country, it is different and hence the pollution concentrations can be much higher. Hence, analysis has to be carried out at the

relevant locations to arrive at the pollutant concentration in the Indian context. These organisms can also pollute the groundwater on river banks as well.

Table 9. 4: Median Event Mean Concentrations for different Urban Land Uses

Pollutant	Units	Residential		Mixed		Commercial		Open/Non-Urban	
		Median	COV	Median	COV	Median	COV	Median	COV
BOD	mg/l	10	0.41	7.8	0.52	9.3	0.31	---	---
COD	mg/l	73	0.55	65	0.58	57	0.39	40	0.78
TSS	mg/l	101	0.96	67	1.14	69	0.85	70	2.92
Total Lead	µg/l	144	0.75	114	1.35	104	0.68	30	1.52
Total Copper	µg/l	33	0.99	27	1.32	29	0.81	---	---
Total Zinc	µg/l	135	0.84	154	0.78	226	1.07	195	0.66
Total Kjeldahl Nitrogen	µg/l	1900	0.73	1288	0.50	1179	0.43	965	1.00
Nitrate + Nitrite	µg/l	736	0.83	558	0.67	572	0.48	543	0.91
Total Phosphorus	µg/l	383	0.69	263	0.75	201	0.67	121	1.66
Soluble Phosphorus	µg/l	143	0.46	56	0.75	80	0.71	26	2.11

COV: Coefficient of variation

Source: Nationwide Urban Runoff Program (US EPA 1983)

9.5.1 Targeted Pollutants

Pollutant removal can be achieved by reducing the volume of storm water runoff discharged and by treating runoff prior to being discharged to off-site areas. Pollutant removal depends on the design storm, soil types,, and other site-specific factors. Table 9.5 identifies general performance effectiveness of storm water.

Table 9. 5: Targeted Pollutant

Pollutant		Filer Strip	Vegetated Swale	Retention Device	Detention Basin	Media Filter Drains	Wet Ponds
Pathogens	E. Coli	H	M	H	H	H	H
	Fecal Coliform	H	M	M	H	H	M
Metals	Total Cu	H	M	M	H	M	H
	Total Pb	H	H	H	H	H	H
	Total Zn	H	H	M	H	H	H
Nutrients	Nitrate (NO ₃)	H	M	L	H	L	M
	Total Kjeldahi Nitrogen	H	M	L	H	M	M
	Total N	H	M	L	H	M	M
	Dissolved P	H	M	L	H	L	M
	Total P	H	M	M	H	M	M
Sediment	TSS	H	H	H	H	H	H

Average pollutant average removal rates from Table 9-14 of NCHRP Report 792: "H" (High) = 67%-100%; "M" (Medium) = 33%-66%; "L" (Low) = 0%-32%.

9.5.2 Treatment methods for urban storm runoff

The onsite treatment methods of storm water are as below:

9.5.2.1 Sand Filters

Sand filters provide storm water treatment for first flush runoff. The runoff is filtered through a sand bed before being returned to a stream or channel. Sand filters are generally used in urban areas and are particularly useful for groundwater protection where infiltration into soils is not feasible. Alternative designs of sand filters use a top layer of peat or some form of grass cover through which runoff is passed before being strained through the sand layer. This combination of layers increases pollutant removal.

One of the main advantages of sand filters is their adaptability. They can be used on areas with thin soils, high evaporation rates, low soil infiltration rates, and limited space. Sand filters also have high removal rates for sediment and trace metals and

have a very low failure rate. Disadvantages associated with sand filters include the necessity for frequent maintenance to ensure proper operation, unattractive surfaces, and odour problems.

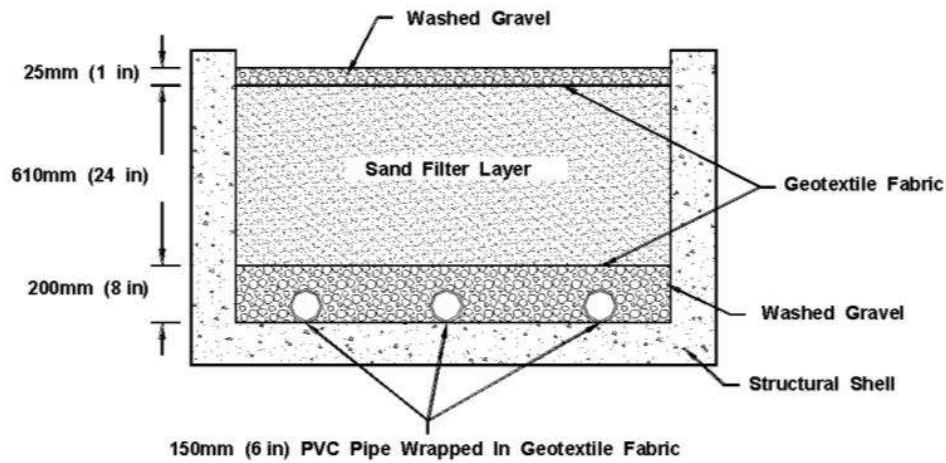

Figure 9. 8: Cross-section schematic of sand filter compartment

Source: FHWA Manual

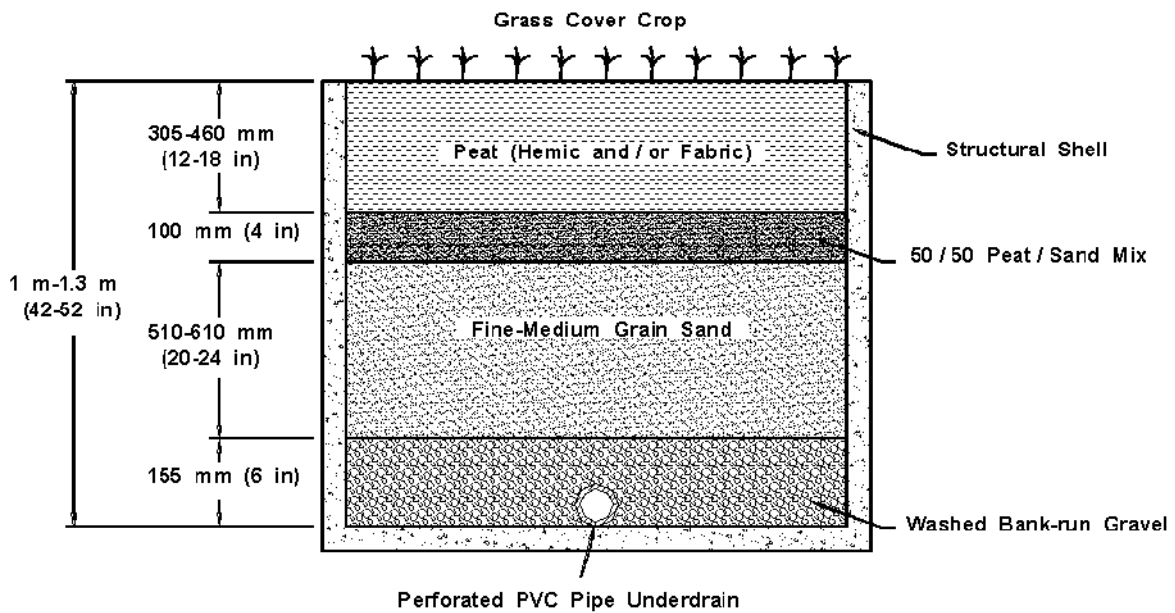

Figure 9. 9: Cross-section schematic of peat-sand filter

Source: FHWA Manual

9.5.2.2 Water Quality Inlets

Water quality inlets are pre-cast storm drain inlets that remove sediment, oil and grease, and large particulates from parking lot runoff before it reaches storm drainage systems or infiltration BMPs. They are commonly known as oil and grit separators. Water quality inlets typically serve highway storm drainage facilities adjacent to commercial sites where large amounts of vehicle wastes are generated, such as gas stations, vehicle repair facilities, and loading areas. They may be used to pre-treat runoff before it enters an underground filter system. The inlet is a three-stage underground retention system designed to settle out grit and absorbed hydrocarbons.

An oil and grit separator consists of three chambers as shown in Figure 9.10; a sediment trapping chamber, an oil separation chamber, and the final chamber attached to the outlet. The sediment trapping chamber is a permanent pool that settles out grit and sediment and traps floating debris. An orifice protected by a trash rack connects this chamber to the oil separation chamber. This chamber also maintains a permanent pool of water. An inverted elbow connects the separation chamber to the third chamber. Advantages of the water quality inlets lie in their compatibility with the storm drain network, easy access, capability to pre-treat runoff before it enters infiltration BMPs, and in the fact that they are unobtrusive. Disadvantages include their limited storm water and pollutant removal capabilities, the need for frequent cleaning (which cannot always be assured), the possible difficulties in disposing of accumulated sediments, and costs.

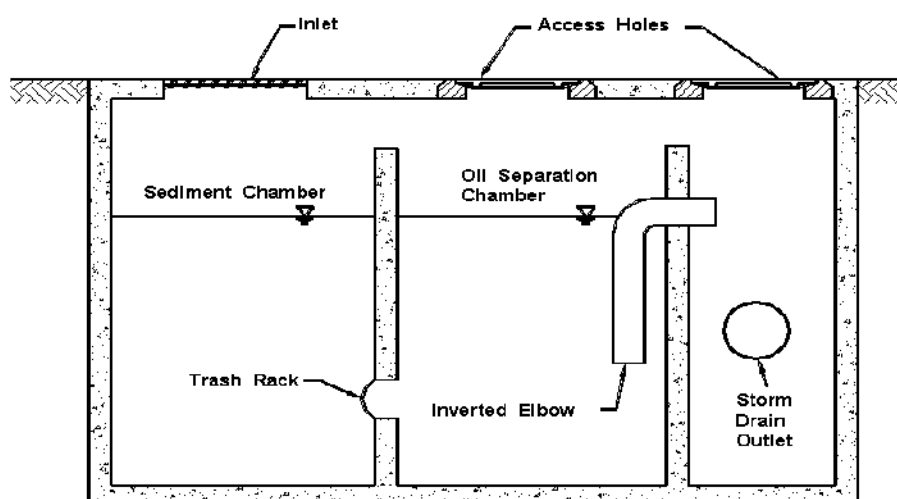

Figure 9.10: Water Quality Inlet

9.5.2.3 Filter Strips

Filter strips are similar in many respects to grassed swales, except that they are designed to only accept overland sheet flow. Runoff from an adjacent impervious area must be evenly distributed across the filter strips.

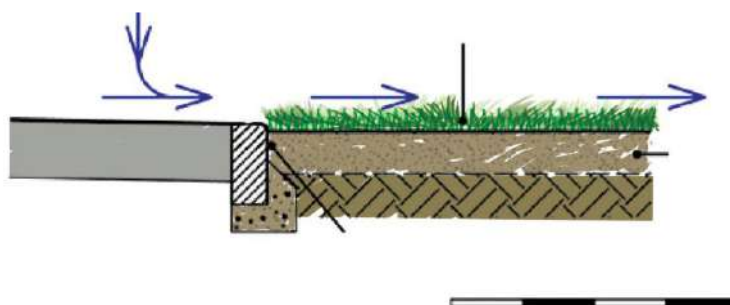

Figure 9. 11: Cross-section of Filter Strip

To work properly, a filter strip must be

- i. Equipped with some sort of level spreading device,
- ii. Densely vegetated with a mix of erosion-resistant plant species that effectively bind the soil,
- iii. Graded to a uniform, even, and relatively low slope, and
- iv. Be at least as long as the contributing runoff area.

CHAPTER 10: INNOVATIVE STORM WATER MANAGEMENT PRACTICES

10.1 General

In today's urban centred growth, integration of innovative approaches for storm water management is getting prominence in city planning. Storm water is now increasingly being valued as a resource to address water security in urban areas. To further strengthen water security, some developed countries use storm water for recharging groundwater aquifer after necessary adequate treatment to pollution laden urban runoff. Further, some developed countries have taken it to next level, whereby, they are integrating smart practices such as Water Sensitive Urban Design (WSUD), Sustainable Urban Drainage System (SuDS), Low Impact Development (LID) and other Best Management Practices (BMP) in their urban planning to economize storm water management on one hand and water security on another hand. In this chapter, a brief description of these innovative approaches is given to sensitize the users. The detailed design of each of these methods requires expertise and detailed analysis of existing ground situation for its integration in city infrastructure and is beyond the scope of this Manual. However, many countries have come out with detailed guideline / Manuals for integrating above concepts in urban city planning.

10.2 Innovative Storm Water Management Practices

Many countries are coming out with innovative storm water practices, suiting to their socio-economic and geographical condition. Under these practices, the maximum utilization of water resources is targeted with minimum investment while keeping the development in harmony with the environment, i.e. a huge shift from conventional storm water drainage system designs. Several models have been attempted across the world suiting to local conditions. The following three models are prominent and can be integrated into the storm water drainage planning and designing. A brief of these models is presented below.

10.2.1 Water Sensitive Urban Design (WSUD)

A new approach termed 'Water Sensitive Urban Design' (WSUD) was developed in the late 1980s for urban planning and design. WSUD provides a broad framework which incorporates storm water related issues like water quality, water quantity and its conservation on one hand and integration of water security, wastewater treatment & reuse, protection of water bodies and environmental & social objectives on the other hand. In nutshell, the paradigm shift under WSUD is to see stormwater as a valuable resource in conjunction with water and treated wastewater and not a mere traditional design for its conveyance and disposal. Internationally, this concept is being used in many cities viz. Melbourne in Australia, USA and Victoria, Ottawa city in Canada and

also this concept is under preparation in Bangalore and Chennai cities in India. The various aspects considered under WSUD is presented in the figure 10.1.

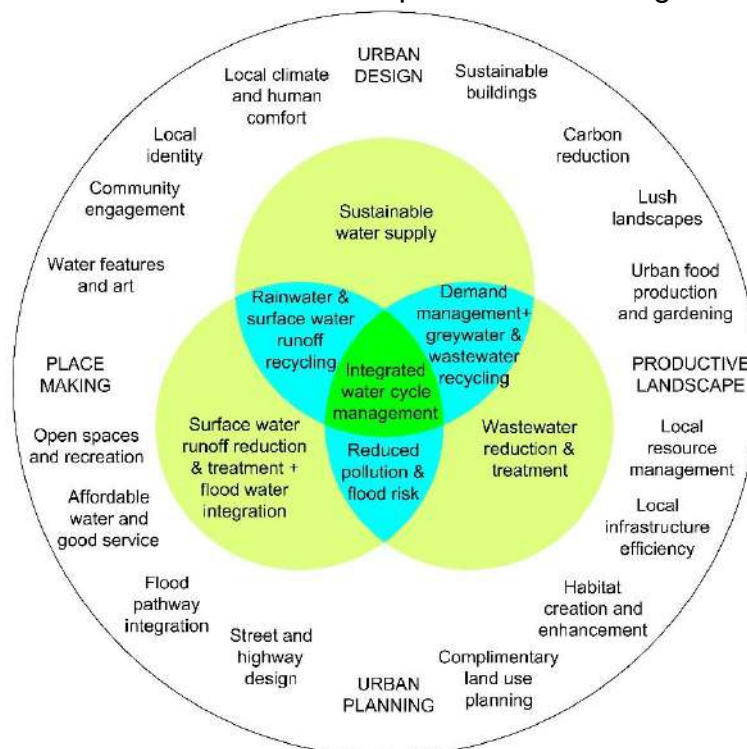

Source: *Water Sensitive Urban Design in the UK – Ideas for built environment practitioners - a scoping study (CIRIA project RP976)*

Figure 10. 1: Aspects of Water Sensitive Urban Design

10.2.1.1 Objective of WSUD

Water Sensitive Urban Design for urban storm water seeks to address, inter alia, the following important aspects:

- i. Minimizing runoff at or near its source, by directing runoff from impervious surface to pervious areas to reduce quantity and improve quality of runoff
- ii. Preserve the existing topography and features of the natural drainage system including waterways and water bodies.
- iii. Integrate public open space with storm water drainage corridors to maximise public access, passive recreation activities and visual amenity, while preserving essential waterway habitats and wildlife movement corridors.
- iv. Preserve the natural water cycle including minimising changes to the natural frequency, duration, volume, velocity, and peak discharge of urban storm water runoff.
- v. Protect surface water and groundwater quality.
- vi. Minimise the capital and maintenance costs of storm water infrastructure.

10.2.1.2 Integration of WSUD in Urban planning and Implementation**a. City Urban Planning**

Following eight components can be integrated into urban city planning for on-ground implementation to achieve the objectives of Water Sensitive Urban Design.

1. Protect water quality

- i. Storm water remains clean and retains its high value
- ii. Implement best management practice on-site.
- iii. Implement non-structural controls, including education and awareness programs.
- iv. Install structural controls at source or near source.
- v. Use in-system management measures.
- vi. Undertake regular and timely maintenance of infrastructure and streetscapes.

2. Protect infrastructure from flooding and inundation

- i. Storm water runoff from infrequent high intensity rainfall events is safely stored and conveyed
- ii. Safe passage of excess runoff from large rainfall events towards watercourses and wetlands.
- iii. Store and detain excess runoff from large rainfall events in parks and multiple use corridors.
- iv. Safely convey excessive groundwater to the nearest watercourse.

3. Minimise runoff

- i. Slow the migration of rainwater from the catchment and reduce peak flows
- ii. Retain and infiltrate rainfall within property boundaries.
- iii. Use rainfall on-site or as high in the catchment as possible.
- iv. Maximise the amount of permeable surfaces in the catchment.
- v. Use non-kerbed roads and car parks.
- vi. Plant trees with large canopies over sealed surfaces such as roads and car parks.

4. Maximise local infiltration

- i. *Fewer water quality and flooding problems*
- ii. Minimise impervious areas.
- iii. Use vegetated swales.
- iv. Use soak wells and minimise use of piped drainage systems.
- v. Create vegetated buffer and filter strips.
- vi. Recharge the groundwater table for local bore water use.

5. Make the most of nature's drainage

- i. *Cost effective, safe and attractive alternatives to pipes and drains*
- ii. Retain natural channels and incorporate into public open space.
- iii. Retain and restore riparian vegetation to improve water quality through bio-filtration.
- iv. Create riffles and pools to improve water quality and provide refuge for local flora and fauna.
- v. Protect valuable natural ecosystems.
- vi. Minimise the use of artificial drainage systems.

6. Minimise changes to the natural water balance

- i. Avoid summer algal blooms and midge problems and protect our groundwater resources
- ii. Retain seasonal wetlands and vegetation.
- iii. Maintain the natural water balance of wetlands.
- iv. No direct drainage to conservation category wetlands or their buffers, or to other conservation value
- v. Wetlands or their buffers, where appropriate.
- vi. Recharge groundwater by storm water infiltration.

7. Integrate storm water treatment into the landscape

- i. Add value while minimising development costs
- ii. Public open space systems incorporating natural drainage systems.
- iii. Water sensitive urban design approach to road layout, lot layout and streetscape.

- iv. Maximise environmental, cultural and recreational opportunities.

8. Convert drains into natural streams

- Lower flow velocities, benefit from natural flood water storage and improve waterway ecology
- Create stable streams, with a channel size suitable for 1 in 1 year design return period rainfall events, equivalent to a bankfull flow.
- Accommodate large and infrequent storm events within the floodplain.
- Create habitat diversity to support a healthy, ecologically functioning waterway.

b. Step by Step Implementation

Step 1: Understand the Site

Step 1 in the design process is about developing a broad overview of the subject site and identifying those issues that may assist or hamper the overall delivery of WSUD practices.

Step 2: Identify Objectives

The implementation of WSUD in a development seeks to achieve a range of outcomes relating to water quality, hydrology, conservation, biodiversity and amenity. Each of these outcomes can be met by ensuring development complies with the appropriate objectives and targets identified for the site.

The objectives should focus on:

- i. Water quality
- ii. Water quantity
- iii. Integrated water cycle management
- iv. Landscape and amenity
- v. Biodiversity enhancement
- vi. Social outcomes

Step 3: Identify Suitable WSUD Measures

To assess whether a WSUD measure is appropriate requires an understanding of the requirements of the WSUD outcomes and the suitability of the particular measure to assist in achieving those outcomes. In developing a proposed WSUD strategy, it is often necessary to review this on an iterative basis, so that the characteristics of different WSUD measures can be appropriately integrated. The WSUD measures, their roles and benefits are given in Table 10.1.

Step 4: Meet with Council and Relevant Authorities

In the majority of situations, it will be beneficial to the overall development process to meet with council officers to:

- i. Discuss the site of the proposed development, including opportunities and
- ii. constraints of the site
- iii. Discuss the concept design of the proposed development
- iv. Establish objectives and targets for the proposed development
- v. Discuss any likely council requirements, including any modelling expectations
- vi. Discuss land and asset ownership issues including future maintenance and
- vii. operation
- viii. Determine the necessary approvals including any State Government approvals

Step 5: Conceptual Site Design

WSUD principles are most effective and economical when integrated into development design at the concept design stage. Each development type may vary significantly and present different WSUD opportunities. There are many ways to incorporate WSUD in development projects to meet the objectives and targets. The design strategies used in a project will depend upon:

- i. The location and geography of the site
- ii. Land use and activity (residential, commercial, industrial)
- iii. Development or redevelopment scale
- iv. Water use and demand (garden irrigation, industrial needs, etc.)
- v. Water sources available, including rainfall, storm water and wastewater
- vi. On-site catchment area (roof and surface)
- vii. Groundwater and soil type
- viii. Infrastructure (building and roads)
- ix. Surrounding environment opportunities and constraints
- x. Operation and maintenance (council or site owner)
- xi. Urban landscape design (architectural and landscape)
- xii. Catchment water quantity and quality objectives and targets

Step 6: Model Base Case (if required by approving authority)

At this stage, sufficient information would have been collected to allow modeling of both the existing site (i.e. pre-development) and the ‘untreated’ developed site that would form the ‘base case’ with which to compare future modeling of the WSUD systems proposed for the development (if required by the approving authority). In the majority of developments, water quality modeling should focus on total suspended solids, total nitrogen, total phosphorus and gross pollutants as the key pollutants of interest, in addition to the hydraulic outcomes. Faecal coliforms and organics should also be considered, depending on the measure being assessed.

Step 7: Locate WSUD Measures

When determining the optimal WSUD measures for a site, some consideration should be given to the site analysis and the opportunities available, and the ‘natural’ or obvious areas for WSUD measures (e.g. overland flow paths). The site analysis may provide information on whether a ‘bottom of catchment’ approach or a distributed approach to WSUD is optimal for the site. The identification of options for the use of water-conserving measures at the design level for:

- Road layout
- Building Design (e.g. encouragement of green roofs)
- Internal services
- Housing layout
- Streetscape (including regulated self-supply options)

A number of planning and design tools based on BPP principles have been developed which relate to the following:

- Public open space networks
- Housing layout
- Road layout
- Streetscape

Table 10. 1: WSUD Measures: Role, Focus, Site Conditions and Benefits

Measure	Focus of WSUD Measure		Potential Benefits	Suitable Site Conditions	Unsuitable Conditions
	Water Quality	Water Quantity			
Demand Reduction	Low	High	Reduction in mains water supply	Residential, commercial and industrial sites	Where water quality does not meet end use requirements

Measure	Focus of WSUD Measure		Potential Benefits	Suitable Site Conditions	Unsuitable Conditions
	Water Quality	Water Quantity			
Rainwater Tanks	Low	High	Storage for reuse. Sediment removal in tank. Frequent flood retardation	Proximity to roof. Suitable site for gravity feed. Need to incorporate into urban design	Non-roof runoff treatment. Where tank water is not used on a regular basis
Rain Gardens	Medium	High	Volume retention. Water quality improvement	Allotment scale	Reactive clay sites. Near infrastructure
Green Roofs	Medium	Medium	Retention of water. Biodiversity	Flat roofs, slopes up to 30 degrees	Roofs that are not structurally suitable
Infiltration Systems	High	Medium	Volume retention. Water quality improvement	Precinct scale	Non-infiltrative soils. High groundwater r levels
Pervious Pavements	High	Medium	Retention and detention of runoff	Allotments, roads and car parks	Severe vehicle traffic movement and developing catchments with high sediment load
Urban Water Harvesting and Reuse	Medium	High	Reduction in mains water supply	Residential, commercial and industrial, generally more viable for precinct scale sites	Locations where demand is limited or adverse impacts to downstream users
Gross Pollutant Traps	High	Low	Reduces litter and debris. Can reduce sediment. Pre-treatment for other measures	Site and precinct scales	Sites larger than 100 ha. Natural channels. Low lying areas
Bioretention Systems	High	Low	Fine and soluble	Flat terrain	Steep terrain. High

Measure	Focus of WSUD Measure		Potential Benefits	Suitable Site Conditions	Unsuitable Conditions
	Water Quality	Water Quantity			
			pollutants removal. Streetscape amenity. Frequent flood retardation		groundwater table
Swales	Low	Low	Medium and fine particulate removal. Streetscape amenity. Passive irrigation	Mild slopes (< 4%)	Steep slopes
Buffer Strips	High	Low	Pre-treatment of runoff for sediment removal. Streetscape amenity	Flat terrain	Steep terrain
Sedimentation Basins	High	Medium	Coarse sediment capture. Temporary installation. Pre-treatment for other measures.	Need available land area	Where visual amenity is desirable
Constructed Wetlands	High	Medium	Community asset. Medium to fine particulate and some soluble pollutant removal. Flood retardation. Storage for reuse. Wildlife habitat	Flat terrain. Need available land area	Steep terrain. High groundwater table
Wastewater Management	Medium	High	Nutrient reduction to receiving environments. Fit for purpose substitution	Where adequate treatment and risk management can be ensured	

Source: Adapted from City of Yarra (2006) and Knox City Council (2002)

Step 8: Model Treated Case (if required by approving authority)

Evaluation and assessment of alternative water management strategies are based on predictions made using forecasting tools. The emergence of new models and design methods to evaluate the use of roof water and storm water, and reuse of treated wastewater allow more reliable assessment of the multiple benefits of utilizing these alternative sources.

Step 9: Objectives Check

At this stage, several iterations may be required to ensure that the majority of objectives set out in Step 2 are achieved. Note that it may not be possible for all objectives to be met and it may be that a degree of compromise is required in some areas to achieve an optimal outcome. Where necessary, if particular objectives are essential, then it may be appropriate to revisit the conceptual site design and/or the type of WSUD measures used.

Step 10: Finalise Measures

Once the final WSUD conceptual design has been developed, it will be necessary to confirm sizing and locations of measures prior to entering the detailed design process. Of key importance at this stage will be the identification of services and completed design elements (e.g. roads, open space areas, final lot layouts, hydraulic design) within which WSUD measures may need to be integrated.

A conceptual design should be developed that shows:

- The location of the WSUD measure(s) within the development;
- The proposed layout of the measure in its specific location (also showing key features such as roads and other services). The proposed layout should also provide detail of proposed access to the WSUD measure for maintenance and monitoring and, where relevant, any surrounding recreational infrastructure. This is to ensure that adequate consideration has been given to ongoing maintenance and that the functionality of open and other recreational spaces is not impeded. Designers may also use the Design Assessment Checklist in each chapter during the concept design to check that no key issues will arise later in the detailed design. At this stage, it will also be appropriate to document operation and maintenance plans, including all ongoing requirements of each of the measures.

10.2.2 Low Impact Development Design

LID is an innovative storm water management approach modeled after nature i.e. **manages rainfall runoff at the source using uniformly distributed decentralized micro-scale controls**. LID is “a storm water management and land development

strategy that emphasizes conservation and the use of on-site natural features integrated with engineered, small-scale hydrologic controls to more closely reflect pre-development hydrologic functions”. This can be accomplished by creating site design features that direct runoff to vegetated areas containing permeable or amended soils, protect native vegetation and open space, and reduce the amount of hard surfaces and compaction of soil. Common LID planning practices include site design planning based on natural land contours and decreasing the impervious surface. These methods include the following:

- Reducing impervious surfaces
- Disconnecting impervious areas
- Conserving natural resources
- Using cluster/consolidated development
- Using xeriscaping and water conservation practices

The basic LID strategy for handling runoff is to reduce the volume and decentralize flows. This is usually best accomplished by creating a series of smaller retention or detention areas that allow localized filtration instead of carrying runoff to a remote collection area for treatment. The basic LID strategy is explained schematically in figure 10.2.

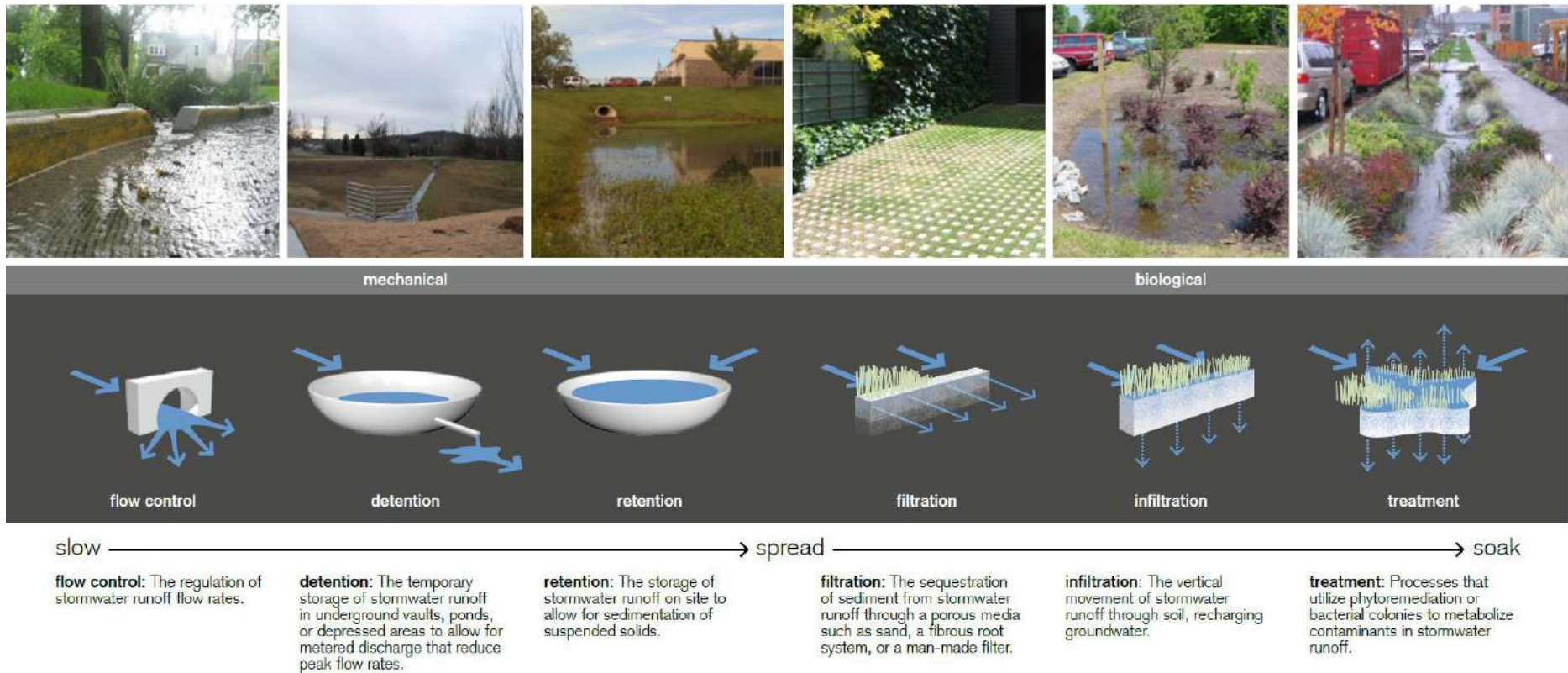

Source: Low Impact Development, design manual for urban areas, University of Arkansas Community Design Center, Fayetteville, North Carolina, United States.

Figure 10.2: Basic LID strategy

10.2.2.1 Objectives of Low Impact Development

Objectives of Low Impact Development (LID) are as follows:

- Protect water quality
- Reduce runoff
- Reduce impervious surfaces
- Encourage open space
- Protect significant vegetation
- Reduce land disturbance

10.2.2.2 Approach for Planning & Implementation of LID

Approaches for achieving objectives of LID can be broadly classified in following categories:

- i. Site Planning
- ii. Hydrologic Analysis
- iii. Integrated Management Practices
- iv. Erosion and Sediment Control
- v. Public Outreach Program

The same is schematically represented in the figure 10.3.

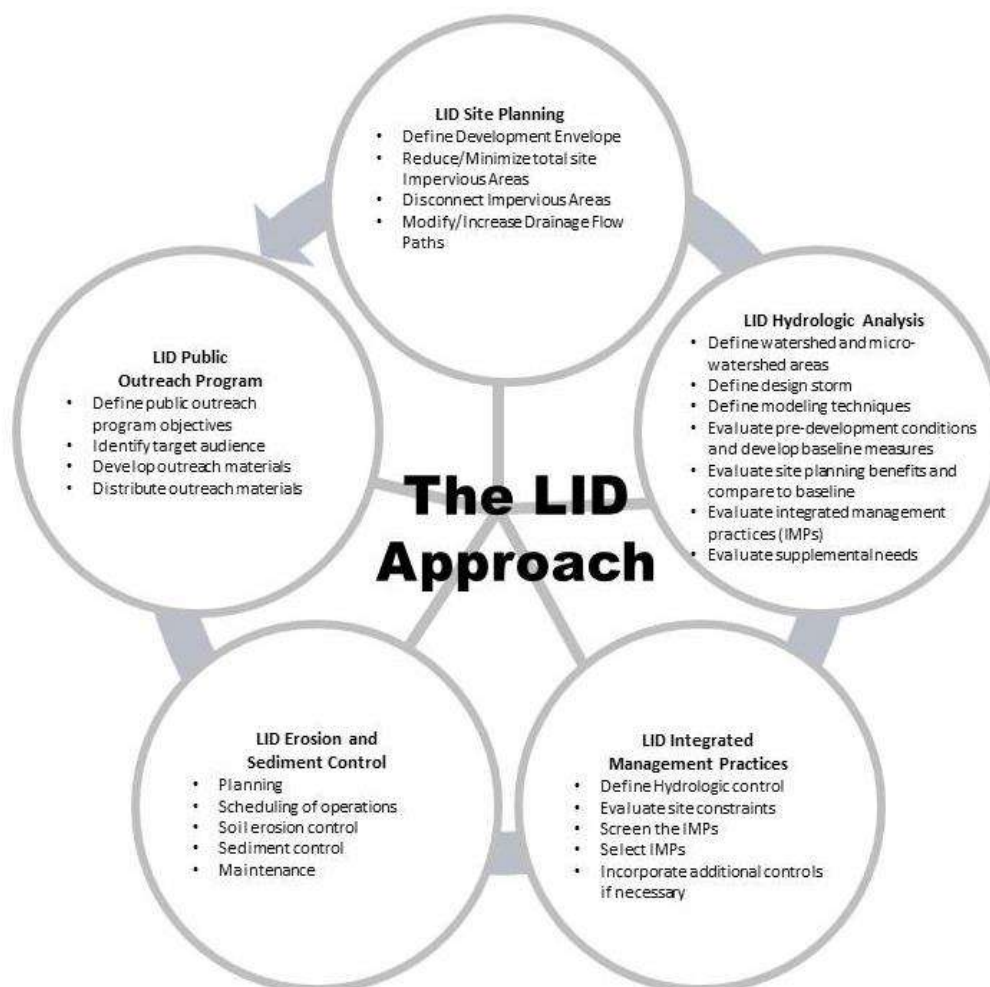

Source: Low-Impact Development Design Strategies, An Integrated Design Approach, Prepared by: Prince George's County, Maryland Department of Environmental Resources Programs and Planning Division, June 1999

Figure 10. 3: LID planning and implementation Approach

To achieve above objectives, a step-by-step process for LID design development is described below:

STEP 1: Define Project Objectives and Goals

- a. Identify the LID objectives for the entire project.
- b. Determine the goals and feasibility for water quality, water quantity, peak runoff control, and on-site use of storm water.
- c. Determine project character/aesthetic. Identify the baseline principles from which LID design decisions will be made by defining the LID technologies that support the concept and visual aesthetic.
- d. Prioritize and rank basic objectives.

STEP 2: Analysis and Site Evaluation

A site evaluation will facilitate LID design development by providing infrastructural, contextual, cultural, and community clues that will assist in the development of a LID program.

- a. Conduct a detailed investigation of the site through collected materials such as drainage maps, utilities information, soils maps, land use plans, and aerial photographs.
- b. Perform an on-site evaluation highlighting opportunities and constraints, such as pollutant hot spots, potential disconnects from Combined Sewer Overflows, slopes etc. Make note of potential LID practices and areas where water quality and quantity controls could be installed.

STEP 3: Create Overlay

- a. Classify the land use on the project site.
- b. Review the proposed architectural plan to identify buildings and structures, open or vegetated space, parking lots, parking lot islands, side yards, vegetated strips adjacent to sidewalks, and buffer areas.
- c. Create an overlay that identifies opportunities for LID devices.

STEP 4: Develop LID Control Strategies

- a. Develop a list of LID control strategies that potentially fulfill the objectives. Determine the appropriate number of LID controls needed. Identify specific LID technologies for the project site and determine how to integrate them, keeping in mind the optimum location, to meet their design objectives.
- b. Specify LID technologies for each land use component.

STEP 5: Design LID Master Plan

- a. Sketch a design concept that distributes the LID devices uniformly around the project site. Keep in mind that some LID technologies can be used to capture storm water from adjacent impervious areas.
- b. Develop a master plan that identifies all key control issues (water quality, water quantity, water conservation) and implementation areas.
- c. Finalize the plan.

STEP 6: Develop Schedule, Funding, Construction, and Implementation Plans

The development process is not a linear or static process but one that is dynamic and adaptable.

STEP 7: Evaluate Success or Modify Design

Developing a storm water management program using LID principles and practices is a dynamic process. Evaluate the design to see if it meets project storm water management objectives.

10.2.3 Sustainable Drainage System (SuDS)

Sustainable drainage systems aim towards maintaining or restoring a more natural hydrological regime, such that the impact of urbanisation on downstream flooding and water quality is minimised. Originally, SuDS were introduced primarily as single purpose facilities however this has now evolved into more integrated systems which serve a variety of purposes, including habitat and amenity enhancement.

SuDS involve a change in our way of managing urban run-off from solely looking at volume control to an integrated multi-disciplinary approach which addresses water quality, water quantity, amenity and habitat. These are referred to as the four pillars of SuDS design as shown in Fig 10.4.

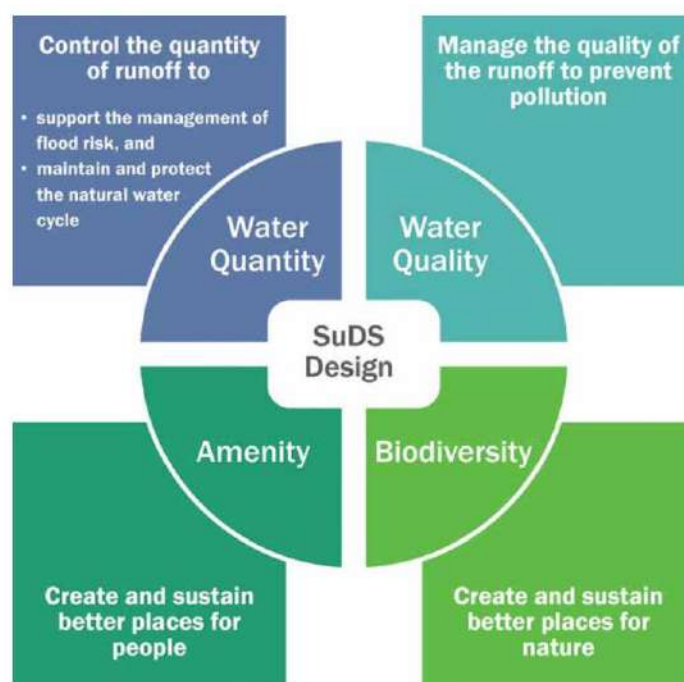

Figure 10.4: SuDS Design Principles

10.2.3.1 Objective of SuDS

Sustainable drainage systems (SuDS) are a natural approach to manage drainage in and around properties and other developments. SuDS work by slowing and holding back the water that runs off from a site, allowing natural processes to break down pollutants. Following two main objective of SuDS are:

1. Minimise the impacts of urban runoff by capturing runoff as close to source as possible and then releasing it slowly
2. Reduces pollutants in the surface water by settling out suspended solids

10.2.3.2 Steps for Design & Implementation of SuDS

SuDS Design can be primarily categorized in three types for implantation purposes:

- i. **Source control** manage storm water runoff as close to its source as possible, typically on site. Typical SuDS options include: **green roofs, rainwater harvesting, permeable pavements and soak ways.**
- ii. **Site control** measures manage the surface water run-off from larger areas, such as part of a housing estate, major roads or business parks. The run-off from larger areas can be channeled to a site control measure using swales (shallow drainage channels) or filter drains. Typical SuDS options include: **bio-retention areas, filter strips, infiltration trenches, sand filters and swales.**
- iii. **Regional control** measures downstream of source and site controls deal with the gathered run-off from a large area. These systems use the same principles as smaller scale SuDS, but can cope with larger volumes of water. Rainwater that passes through small SuDS can feed into larger SuDS which deal with the gathered run-off from a wide area. It is best to connect the flows between SuDS components with swales, filter drains or ditches and avoid the use of pipes. Typical SuDS options include: **constructed wetlands, detention ponds and retention ponds.**

The SuDS planning process is schematically explained in Fig 10.5.

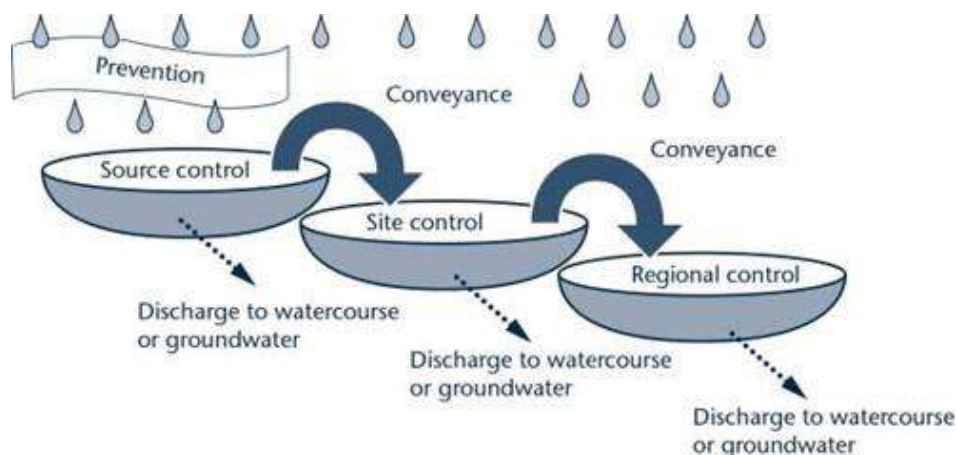
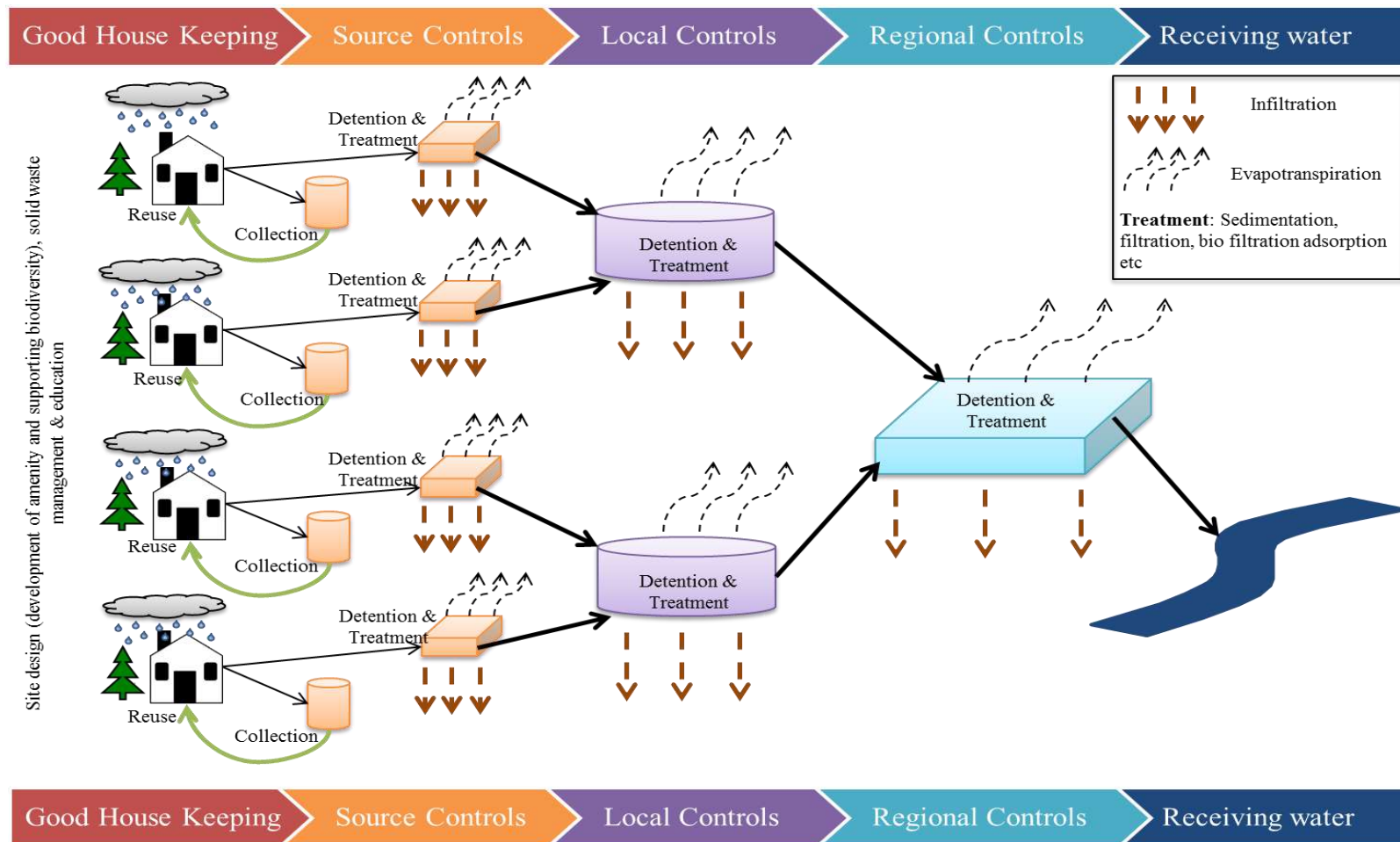

Figure 10.5: SuDS planning process

As the treatment train progresses, the number of interventions decrease, but their individual size increases. For example the source controls could be each house having a rainwater tank, the local control may be 5 houses 'share' a wet swale, and the regional control may be that 50 houses 'share' a wetland. The treatment train is shown in the Figure 10.6:



Source: <http://www.uwm.uct.ac.za/uwm/suds/principles>

Figure 10.6: SuDS Treatment Train

The successful achievement of sustainable urban drainage does not solely rely on the use of engineered techniques to control and treat runoff. 'Good housekeeping' measures, such as safe storage and handling of oils and chemicals, street sweeping and control of sediment run-off from construction sites are an essential component of SuDS. Public awareness is also an important factor in ensuring the successful implementation of sustainable drainage practices.

10.2.3.3 Benefits of SuDS

The benefits of SuDS are:

- Preventing water pollution
- Slowing down surface water run-off and reducing the risk of flooding
- Reducing the risk of urban flooding during heavy rain
- Recharging groundwater to help prevent drought
- Providing valuable habitats for wildlife in urban areas
- Creating green spaces for people in urban areas.

SuDS are very flexible and there are a number of ways that they can be applied to provide great drainage that are both value for money and inspirational.

10.2.4 Storm water Management and Road Tunnel (SMART tunnel)



SMART tunnel is a multipurpose tunnel that doubles up as roadway for vehicles and a channel to get rid of storm water. The main objective of this tunnel is to solve the problem of flash floods and also to reduce traffic jams. There are two components of this tunnel, the storm water tunnel and motorway tunnel. The storm function of the SMART tunnel is to divert flood water caused by heavy rain into a bypass tunnel under the motorway tunnel. If the rains continue and flooding gets worse the motorway tunnel is closed to vehicles - allowing water to flow through both the traffic and bypass tunnels. The tunnel project is implemented in Kuala Lumpur, Malaysia, Japan, Dubai etc.



10.2.5 Decentralized Innovative intervention in storm water drainage designs

Storm water runoff control at decentralized level is of immense use and not only meets the local requirement of water for domestic uses but also can recharge ground water and minimize investment in storm water drainage infrastructure. In addition, it can contribute immensely to prevent frequent flooding in low lying areas. Decentralized



innovative interventions that may be integrated in design / incentivize to realize above mentioned benefits are given in Table 10.2:

Table 10. 2: Decentralized Innovative intervention in storm water drainage designs

Design element	Description and objectives	Example
Residential		
Rooftop Rainwater harvesting	Element to collect rainwater from roofs and use for non-potable water uses	
Permeable pavement	Permeable surface that rains through voids between solid parts of the pavement to infiltrate rainwater from pavements residential areas	
Rain garden	Element vegetated to infiltrate rainwater from roofs	



Design element	Description and objectives	Example
Infiltration trench	Stone-filled trench to infiltrate rainwater from roofs and pavements residential areas	
Soakaway	Sub-surface structure to infiltrate rainwater from roofs	
SIDEWALK		
Rain garden	Element vegetated to infiltrate rainwater from sidewalk areas	

<p>Rill</p>	<p>Open vegetated channel to transport rainwater to infiltration areas</p>	
<p>STREET</p>		
<p>Channel</p>	<p>Channel to transport rainwater to infiltration areas</p>	
<p>Permeable pavement</p>	<p>Permeable surface that drains through voids between solid parts of the pavement to infiltrate rainwater from sidewalk areas</p>	

<p>Infiltration trench</p>	<p>Stone-filled trench to infiltrate and store rainwater from roads</p>	
<p>Pervious Pavement</p>	<p>Pervious surface that drains through voids between solid parts of the pavement to infiltrate rainwater</p>	
<p>Parking</p>		
<p>Modular pavement</p>	<p>Modular surface to infiltrate rainwater from the parking surface</p>	
<p>Infiltration trench</p>	<p>Stone-filled trench to infiltrate rainwater from parking surface</p>	

<p>Bioretention</p>	<p>Depression backfilled with a soil mixture with vegetation to improve water quality from the parking surface</p>	
<p>Open space, flood plain, green infrastructure and infiltration area</p>		
<p>Modular pavement</p>	<p>Modular surface to infiltrate rainwater</p>	
<p>Natural pavement</p>	<p>Natural surface to infiltrate rainwater</p>	
<p>Swale</p>	<p>Vegetated area to transport and infiltrate rainwater</p>	

<p>Filter drain</p>	<p>Gravel trench to drain rainwater</p>	
<p>Infiltration basin</p>	<p>Depression with vegetation area to infiltrate rainwater</p>	
<p>Wetland</p>	<p>Retention pond with aquatic vegetation to treat rainwater</p>	
<p>Retention pond</p>	<p>Artificial pond to store water and release it slowly</p>	

<p>Bioretention</p>	<p>Depression backfilled with a soil mixture with vegetation to retain rainwater</p>	
<p>Other spaces – Spaces between infrastructures</p>		
<p>Infiltration basin</p>	<p>Depression with vegetation to infiltrate rainwater</p>	
<p>Natural retention</p>	<p>Slope area with vegetation to infiltrate rainwater</p>	

Above decentralized options are given to sensitize the users about their importance in local planning in the city and at individual household level and community level. However, detail design of each of these decentralized options to be carried out under guidance of experts and also based on the type designs available in typical Manuals like CGWB and CPWD etc.

CHAPTER 11: CONSTRUCTION OF STORM WATER DRAINS

11.1 General

This chapter describes the method of construction of storm water channels and conduits such as laying and jointing of storm water conduits, and construction of storm water drains, types of construction materials. Construction of manholes and other appurtenant structures etc. has also been described.

11.2 Implementation of the project

Before the implementation of any project, the following prerequisites are mandatory:

- i. Administrative approval
- ii. Expenditure sanction
- iii. Technical sanction
- iv. Availability of funds

No work should normally be commenced or any liability thereon incurred until an administrative approval has been obtained, a properly prepared detailed estimate has been technically sanctioned and where necessary expenditure sanction has been accorded and allotment of funds made.

The execution of a project/work has two stages, viz. the '**Pre-construction stage**' and the '**Construction stage**'. The following activities are involved in these stages:

11.2.1 Pre-construction stage

Following prerequisites are mandatory before the construction work is taken up for the execution of the project:

1. Requisition from the client
2. Preparation of site/soil data, and assessment of the feasibility of services such as water supply, electricity, drainage, and sewerage, etc.
3. Approval of the preliminary plans by the client
4. Preparation of preliminary estimate
5. Approval of the preliminary estimate by the client
6. Preparation and submission of the plans to the Local Bodies for their approval

7. Approval of plans by the Local Bodies
8. Preparation of preliminary structural design
9. Preparation of structural drawings
10. Preparation of detailed working drawings
11. Preparation of detailed estimates for laying of storm water channels/conduits and all services (civil, electrical and mechanical)
12. Preparation of NIT and call of pre-qualification applications, wherever applicable
13. Selection of contractors from the pre-qualification applications wherever applicable
14. Call of tenders and pre-bid conference wherever applicable
15. Receipt/Opening of tenders
16. The decision on tender and award of work

11.2.2 Construction stage

1. Execution of work and contract management.
2. Completion of work.
3. Testing and commissioning.
4. Completion certificate from Local Body, including fire clearance.
5. Handing over to the client.
6. Settlement of accounts

11.3 Construction of Storm water conduits

Steps involved in the construction of storm water flexible and rigid pipe are as follows:

1. Removal of pavement and disposal of excavated materials from the ground.
 2. Trench excavation.
 3. Sheet piling and bracing of the sides of the trenches wherever necessary to support the sides against caving.
 4. Dewatering the trenches where necessary.
 5. Protection of underground Services
 6. Bedding, Laying, and Jointing of Conduits
 7. Backfilling of trenches
 8. Removal of sheet piling or bracing
-

11.3.1 Removal of pavement

The removal of pavement is often necessary as the first step in conduit construction. It may be done by hammer and chisel or mechanically with pneumatic hammer fitted with various cutting tools. Excavated material should be safely disposed of.

11.3.2 Trench Preparation

11.3.2.1 Dimensions

The width of a conduit trench depends on the soil condition, type of side protection and the working space required at the bottom of the trench for smooth installations. Increase in width over the required minimum would unduly increase the load on pipe and cost of road restoration. Considering all above factors, the minimum trench width is specified as per Table 11.1.

11.3.2.2 Excavation

Excavation of conduit trenches shall be in straight lines as much as possible and to the correct depths and gradients as specified in drawings. However, because of inherent flexible property, these pipes can also be laid at a very wide and smooth curvatures without transitional manholes. Instead of conventional manholes, the specified fittings such as tees and bends, etc. can be used at transitions.

Table 11. 1: Minimum Trench Widths

SI No.	Pipe Diameter (mm)	Trench Width (m)
i)	75 to 200	0.6
ii)	250	0.7
iii)	300	0.8
iv)	400	0.9
v)	600	1.2
vi)	800	1.3
vii)	900	1.6
viii)	1000	1.8
ix)	1200	2.0

Excavated spoils shall not be deposited in the near proximity to prevent the collapse of the side of the trenches. The sides of the trench shall, however, be supported by shoring (where necessary) to ensure proper and speedy excavations and concurrently ensuring necessary protections to contiguous structures. In the event, the presence of groundwater is likely to cause instability in soil conditions. A wellpoint system may be

adopted for lowering of groundwater table below the requisite trench bed level. If excavation is made deeper than necessary the same shall be filled and compacted.

11.3.2.3 Shoring/Mild steel sheet piling

The protective shoring works shall be strong enough to prevent caving in of trench walls or subsidence of contiguous areas adjacent to the trench. For wider and deeper trenches, a system of wall plates (wales) and struts of heavy timber section is commonly used as per the requisite structural design. In non-cohesive soils with high groundwater table, continuous interlocking mild steel sheet piling may be necessary to prevent excessive soil movements due to groundwater percolation. Such sheet piling shall extend 1.5 m below the trench bottom unless the lower soil strata are adequately cohesive.

11.3.2.4 Underground services

The underground public and private utility services exposed due to the excavation shall be effectively supported under the guidance of the owners of such services.

11.3.2.5 Dewatering

Conduit installation trenches shall be adequately dewatered for the placement of pipe at proper gradient till the pipe is integrated through socket and spigot joint/coupler assembly with the already laid segment.

11.3.2.6 Floatation of Flexible pipe

Precautions are to be taken to arrest floating of installed conduit segments against buoyant forces in case of sudden accumulation of water in the trench. The diameter wise minimum cover necessary to counteract the buoyant forces is given in Table 11.2. For exceptional cases of the higher level of groundwater, additional anchoring at equal intervals would be necessary.

Table 11. 2: Required minimum cover to prevent floatation

SI No.	Nominal Diameter mm	Minimal Cover mm
(1)	(2)	(3)
i)	75	65
ii)	100	77
iii)	150	102
iv)	200	127
v)	250	178
vi)	300	368

Sl No.	Nominal Diameter mm	Minimal Cover mm
vii)	400	505
viii)	600	711
ix)	900	1067
x)	1050	1219
xi)	1200	1372

NOTE- Computation is based on the pipes being completely empty, water table at the ground surface, solid density of 2083 kg/m³ and a soil friction angle appropriate for most sand/ gravel mixture. The average of the inside and outside diameters was used to determine solid and water displacement.

11.3.3 Pipe Bedding for rigid pipes

Where storm water conduits have to be laid in soft underground strata or in reclaimed land, the trench shall be excavated deeper than what is ordinarily required. The trench bottom shall be stabilized by the addition of coarse gravel or rock. In case of very bad soil, the trench bottom shall be filled in with cement concrete of appropriate grade. In the areas subject to subsidence, the pipe should be laid on suitable supports or concrete cradle supported on piles. In the case of cast-in-situ, an RCC section with both transverse and longitudinal steel reinforcement shall be provided when intermittent variations in soil bearing capacity are encountered. In case of long stretches of very soft trench bottom, soil stabilization shall be done either by rubble, concrete or wooden crib.

11.3.3.1 Type of Bedding

The type of bedding (granular, concrete cradle, full concrete encasement, etc.) would depend on the soil strata and depth at which pipe is laid. The load due to backfill superimposed load (live load) and the three-edge-bearing strength of pipe (IS: 458) are the governing criteria for selection of appropriate bedding factors. Factor of safety is taken as 1.5

The type of bedding to be used depends on the bedding factor, and the matrix of type of bedding for different diameters and different depths has been tabulated in Table 11.3 and Table 11.4.

Table 11. 3: Type of bedding for storm water conduits

Bedding Factor	Type of Bedding
Up to 1.9	Class B Granular (GRB)
1.9 - 2.8	Class Ab: Plain Concrete Cradle(PCCB)
2.8 - 3.4	Class Ac : Reinforced Concrete cradle (RCCB) with 0.4 % Reinforcement
> 3.4	Class Ad : Reinforced concrete arch with 1.0% reinforcement

Table 11. 4: Selection of bedding for different depths and different diameters

Diameter		Bedding type for cover depth in m			Diameter		Bedding type for cover depth in m		
mm	up to 2.5	2.5-3.5	3.5-5.0	5.0-6.0	mm	up to 2.5	2.5-3.5	3.5-5.0	5.0-6.0
400	Ab	Ab	Ab	Ac	1400	B	Ab	Ab	Ab
500	Ab	Ab	Ab	Ab	1500	B	Ab	Ab	Ab
600	B	Ab	Ab	Ab	1600	B	Ab	Ab	Ab
700	B	Ab	Ab	Ab	1800	B	Ab	Ab	Ab
750	B	Ab	Ab	Ab	2000	B	Ab	Ab	Ab
800	B	Ab	Ab	Ab	2200	B	Ab	Ab	Ac
900	B	Ab	Ab	Ab	2400	B	Ab	Ab	Ac
1000	B	Ab	Ab	Ab	2600	B	Ab	Ab	Ac
1200	B	Ab	Ab	Ab	2800	B	Ab	Ab	Ac

11.3.3.2 Classes of Bedding for Trench Conditions

Four classes, A, B, C, and D of bedding used most often for pipes in trenches are illustrated in Figure 11.1. Class A bedding may be either concrete cradle or concrete arch. Class B is bedding having a shaped bottom or compacted granular bedding with a carefully compacted backfill. Class C is ordinary bedding having a shaped bottom or compacted granular bedding but with a lightly compacted backfill. Class D is one with a flat bottom trench with no care being taken to secure compaction of backfill at the sides and immediately over the pipe and hence is not recommended.

Class B or C bedding with compacted granular bedding is generally recommended. The shaped bottom is impracticable and costly and hence is not recommended.

The pipe bedding materials must remain firm and not permit displacement of pipes. The material has to be uniformly graded or well graded. Uniformly graded materials include pea gravel or one-size materials with a low percentage of over and undersized particles.

Well-graded materials containing several sizes of particles in stated proportions, ranging from a maximum to minimum size coarse sand, pea gravel, crushed gravel, crushed screenings, can be used for pipe bedding.

Fine materials or screenings are not satisfactory for stabilizing trench bottoms and are difficult to compact in a uniform manner to provide proper pipe bedding.

Well-graded material is most effective for stabilizing trench bottom and has a lesser tendency to flow than uniformly graded materials. However, uniformly graded material is easier to place and compact above pipes.

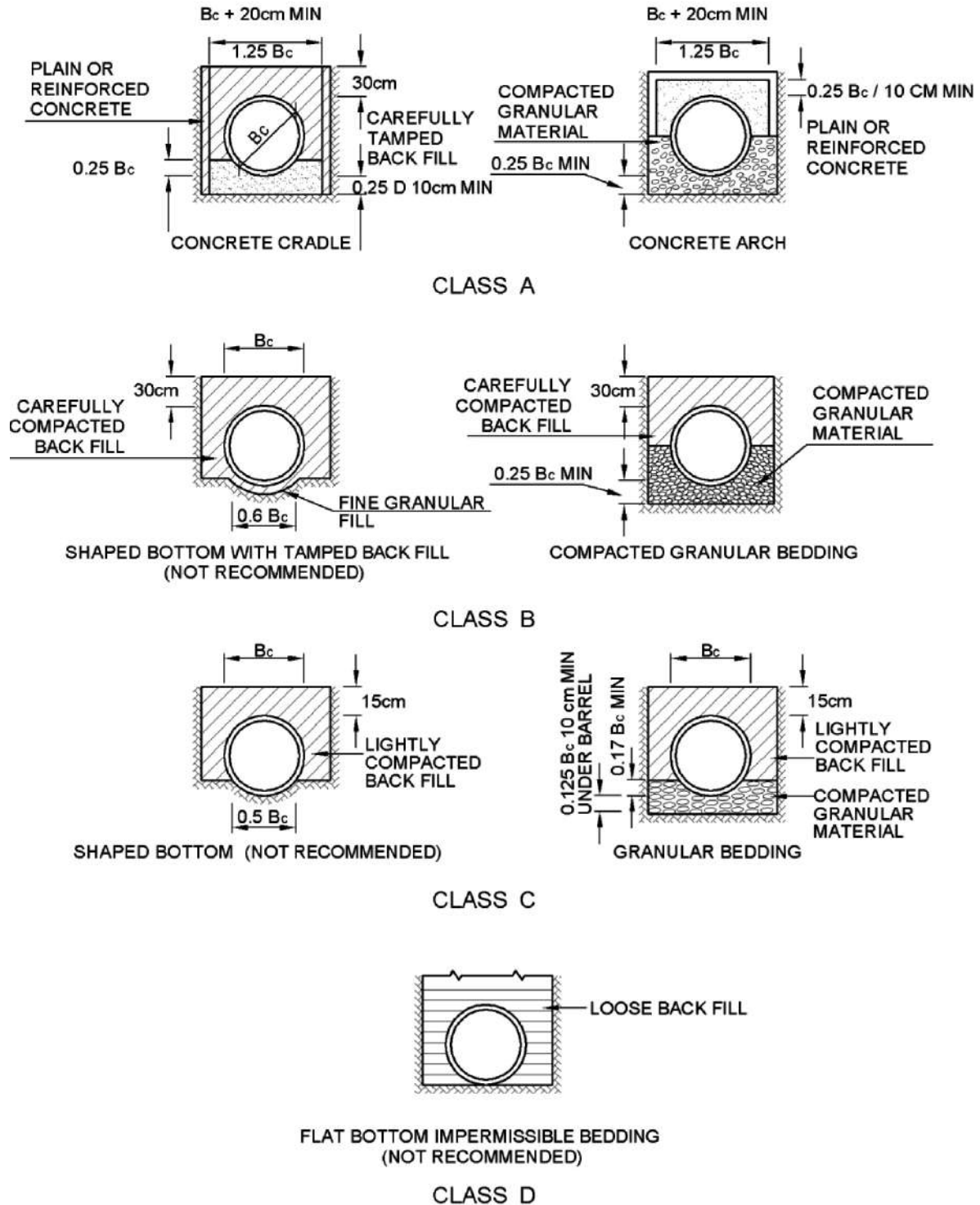

NOTE : IN ROCK, TRENCH IS EXCAVATED AT LEAST 15cm BELOW THE BELL OF THE PIPE EXCEPT WHERE CONCRETE CRADLE IS USED.

Figure 11.1: Classes of bedding

11.3.4 Bedding of Flexible pipe

- a) Normally, even for the maximum combined loading (wheel load + backfill), any form of cement concrete structural bedding would not be necessary.
- b) For maintenance of conduit slopes, the initial backfill envelops with sand or gravel (as computed through structural design of buried flexible conduit) over a single BFS would be sufficient.
- c) In the event, anchorage becomes imperative the transverse concrete anchorage blocks spaced at a suitable interval shall also act as chairs for defining and maintaining the conduit slopes.

11.3.5 Laying of Rigid Storm water conduit

In laying pipe, the centre of each manhole shall be marked by a peg. Two wooden posts 100 mm x 100 mm and 1800 mm high shall be fixed on either side at nearly equal distance from the peg or sufficiently clear of all intended excavation. The sight rail, when fixed on these posts, shall cross the centre of manhole. The sight rails made from 250 mm wide x 40 mm thick wooden planks and screwed with the top edge against the level marks shall be fixed at distances more than 30 m apart along the pipe alignment. The centre line of the pipe shall be marked on the sight rail. These vertical posts and the sight rails shall be perfectly square and planed smooth on all sides and edges. The sight rails shall be painted half white and half black alternately on both the sides and the tee heads and cross pieces of the boning rods shall be painted black. When the conduits converging to a manhole come in at various levels, there shall be a rail fixed for every different level.

The boning rods with cross-section 75 mm x 50 mm of various lengths shall be prepared from wood. Each length shall be a certain number of meters and shall have a fixed tee head and fixed intermediate cross pieces, each about 300 mm long. The top edge of the cross pieces shall be fixed at a distance below the top edge equal to, the outside dia. of the pipe, the thickness of the concrete bedding or the bottom of the excavation, as the case may be. The boning staff shall be marked on both sides to indicate its full length.

The posts and the sight rails shall in no case be removed until the trench is excavated, the pipes are laid, jointed and the filling is started.

When large pipelines are to be laid or where sloped trench walls result in top-of-trench widths too great for practical use of sight rails or where soils are unstable, stakes set in the trench bottom itself on the pipeline, as a rough grade for the pipe is completed, would serve the purpose.

11.3.6 Laying and Jointing of Flexible pipe

11.3.6.1 Laying

11.3.6.1.1 For shallow trenches

Place the pipe manually on the initial backfill envelope directly.

11.3.6.1.2 Deep trenches with shoring/mild steel sheet Piling

- a) Make the trench reasonably free from groundwater and other liquids.
- b) Place the pipe on the top-level cross-struts of the timber shoring/mild steel sheet piling framework.
- c) Dismantle one/two cross struts and lower the pipe to the immediate lower layer of the cross struts and re-fixes the struts immediately.
- d) In the same manner, reach up to the initial backfilling and place the pipe at proper slope.
- e) Ensure anchorage, if any, after laying.

11.3.6.2 Jointing

Various methods for jointing such as regular coupler made by the online process, spigot and sockets are used. The moulded socket will have a suitable internal surface with profile ribs for insertion of the next pipe into it. The socket end of the pipe to be inserted will have corrugated outer layer. On first valley segment of corrugated pipe (destined to be pushed into the coupler) one elastomeric rubber ring needs to be placed which is pushed into the coupler socket. This provides sufficient gripping lock and leak-proof joint. A similar system is also used for fabricated accessories or moulded fittings required such as tee, bends, elbows, reducer end caps for the purpose of installation of the system related to drainage/sewerage. For quality connections following steps are to be ensured, failing which the performance aspects are to be severely compromised:

- a) The non-coupler end needs to be thoroughly cleared and shall be free from any foreign material.
- b) Use a clean rag or brush to lubricate the non-coupler end with lubricant.
- c) Clean and lubricate the coupler end of the pipe to be laid in a similar manner.
- d) Lubricate the exposed gasket in the same manner with pipe lubricant.

- e) Keep the lubricated non-coupler end free from dirt, backfill material, and foreign matter so that the joint integrity is not compromised.
- f) Push the coupler into non-coupler and align properly. Always push coupler end into the non-coupler end. For smaller diameter pipes simple manual insertion shall be sufficient. In every methodology, it should be ensured that the coupler end is adequately 'homed' within non-coupler end to ensure installation and tight joining seal. Therefore, prior to insertion always place a homing mark on appropriate corrugation of the non-coupler end.

11.3.6.2.1 Jointing different pipe types or sizes

Sewerage/ drainage system often encounters connecting pipes of different materials/sizes, etc. The fittings or adapters specifically designed for the purpose are available.

A selection of fittings designed to make the transition from one material directly to another is also available. In few cases, fitting may need to be used in combination with separate manufacturer's gasket or coupler to give proper effect to the transition.

11.3.6.3 Manholes and Catch Pit Connections

Brick masonry manholes can also be used at changes in pipe material, size, grade, direction, and elevation. Manufacturer specified pre-fabricated appurtenant structures made of thermoplastic materials shall also be available for onsite user-friendly installations. The similar methodology shall be followed for integration of catch pits.

11.3.6.4 Conduit Connections

Other connecting lines shall be integrated with the already laid system in the same manner as of original pipelines.

11.3.6.5 Type of pipe material and jointing of storm conduits (rigid pipe)

11.3.6.5.1 Reinforced Cement Concrete Pipes (R.C.C Pipes)

The reinforced cement concrete pipes (IS:458-1988) are non-pressure pipes available under three classifications of NP₂, NP₃, NP₄ That are commonly used in storm water conduits under appropriate loading conditions.

The R.C.C. pipes shall be laid in position over either concrete cradle or on the plain cement concrete bedding, 150 mm plain cement concrete (1:3:6) with carefully packed backfill of earth soil or dug material if suitable. The abutting faces of the pipes being coated by means of a brush with bitumen in liquid condition. The wedge-shaped groove at the end of the pipe shall be filled with sufficient quantity of either special

bituminous compound or sufficient quantity of cement mortar of 1: 3. The collar shall then be slipped over the end of the pipe and the next pipe butted well against the plastic ring by appliances so as to compress roughly the plastic ring or cement mortar into the grooves. Care is taken to see that concentricity of the pipes and the levels are not disturbed during the operation. Spigot and socket (S&S) R.C.C. Pipes shall be laid with pipe joints caulked with tarred gasket in one length for each joint and sufficiently long to entirely surround the spigot end of the pipe, The gasket shall be caulked lightly home but not so as to occupy more than a quarter of the socket depth, The socket shall then be filled with a mixture of one part of cement and one part of clean fine sand mixed with just sufficient quantity of water to have a consistency of semi-dry condition and a fillet shall be formed round the joint with a trowel forming an angle of 45 degrees with the barrel of the pipe. Rubber gaskets may also be used for jointing.

11.3.6.5.2 Cast –In Situ Reinforced Concrete Pipes

For conduit sizes beyond 2 m internal diameter cast-in-situ concrete sections shall generally be used, the choice depending upon the relative costs worked out for the specific project. The concrete shall be cast in a suitable number of lifts usually two or three. The lifts are generally designated as the invert, the sidewall and the arch.

11.3.6.6 Type of pipe material and jointing of storm conduits of Flexible pipe

11.3.6.6.1 HDPE Pipes

PE pipes are manufactured in three grades namely LDPE, MDPE, HDPE. HDPE pipes are commonly used in storm water conduits. HDPE pipes are manufactured in India conforming to (IS-4984-1995). They are available in standard length in 6.0m and 12.0m. The installation of HDPE pipes should conform to IS 7634 part 2: 1975. Bedding materials may be dug materials, imported materials, or as per design class of bedding given in foregoing section. The pipes are joined either in butt fusion welding, electrofusion welding or mechanical joints such as flange joints, telescopic rubber gasket joint, compression joint, etc. Manufacturer's jointing procedure may also be followed.

11.3.6.6.2 UPVC Pipes

These pipes are manufactured in India conforming to IS:4985-1988. They are available in a standard length of 6.0m. Pipes are manufactured under various pressure classifications such as class 1, class 2, class 3, and class 4. Installation of pipe should conform to IS:7634 part 3: 1975. Bedding may of dug materials, processed granular materials or as per designed bedding as mentioned in foregoing sections. Jointing of

pipes may be carried out by three methods such as 1) PVC solvent welded joints 2) Flanged joint 3) Push-fit type rubber ring joint.

11.3.6.6.3 Glass fiber reinforced plastic pipes (GRP PIPES)

GRP pipes are now manufactured in India conforming to IS: 12709: 1994. Standard lengths of pipe in 6.0 m, 9.0 m, and 12.0 m are available. Bedding may be dug materials, imported materials or as per design is given in foregoing section. Jointing of GRP pipes is carried out by one of the following methods as per site requirement:

- i. Socket and spigot gasket joint- provided with grooves either on the socket or in the spigot to retain an elastomeric gasket that shall be the sole element of the joint to provide water tightness
- ii. Coupling joints- coupling with rubber gasket placed on each side are often used for jointing GRP pipes
- iii. Mechanical coupling- Mechanical flexible couplings made of C/I, D/I, Steel are also used for GRP to GRP or GRP to other pipe joints

11.3.6.6.4 Structured Wall PE pipe

The IS 16098 (Part I), IS 16098 (Part II) and EN 13476 also cover the performance requirements for the respective materials. These pipes are manufactured with externally corrugated wall configuration i.e. Double Wall (smooth inside layer & annular Corrugated outside wall) PE Pipes hereinafter called DWC PE Pipes. The pipes are integrated with coupler (socket) ends and joined through extremely user-friendly Push-fit jointing system without application of any foreign material.

11.3.6.7 Backfilling of the Trenches of Rigid pipes

Backfilling of the storm water conduit trench is a very important consideration in conduit construction. The method of backfilling to be used varies with the width of the trench, the character of the material excavated, the method of excavation and the degree of compaction required. In developed streets, a high degree of compaction is required to minimize the settlement while in less important streets, a more moderate specification for backfill may be justified. In open country, it may be sufficient to mound the trench and after natural settlement return to re-grade the areas.

11.3.6.8 Construction of Backfill Envelope and Backfilling of the Trenches of Flexible pipe

These pipes and well-compacted backfill envelope work together to support soil and traffic load.

In general, material used for the construction of the backfill envelope around the pipe comprises the following:

- a) Initial backfill
- b) Side fill
- c) Top backfill

The material for backfill envelop shall be as per the structural design of flexible buried conduit. It can be the same material that was removed in the course of excavation or it can be fine sand/coarse sand/gravel depending on the overburden and superimposed load, but it should not be the concrete which invariably induces undesired rigidity in the system.

The remaining portion of backfilling shall be the materials that were removed in the course of excavation. These materials shall consist of clean earth and shall be free from large clod or stone above 75 mm, ashes, refuse and other injurious materials.

After completion of laying of pipes etc. first, the backfill envelope shall be constructed as per design around pipe. Voids must be eliminated by knifing under and around pipe or by some other technique and compacted with necessary watering, either by hand rammers or compactors to a possible maximum level of proctor density.

Backfilling shall start only after ensuring the water tightness test of joints for the concerned conduit segments. However, a partial filling may be done keeping the joints open. Precautions shall be taken against floatation as per the specified methodology and the minimum required cover.

11.3.6.9 Removal of sheeting or bracing

Sheeting driven below the spring line of a storm water conduit shall be withdrawn slowly at a time as the back-filling progresses. To avoid any damage to buildings, cables, gas mains, water mains, sewers, etc. near the excavation or to avoid disturbance to the conduit already laid, portions of the sheeting may be left in the trenches.

11.3.7 Storm water conduit appurtenant Structures

Appurtenant structures besides of storm water conduit system consist Manholes, storm water inlet structures, siphons, flap gates, outfall structures, etc. which are essential for the proper functioning of the storm drainage system. Therefore this

section discusses these structures giving general description with specific emphasis on the features considered necessary for appropriate design.

11.3.7.1 Manhole

Manholes are openings constructed along conduit alignment whose primary function is to provide convenient access to the storm drainage system for inspection and maintenance. They also serve as a flow junction and can provide ventilation and pressure relief to the storm drainage system. They are of several configurations like rectangular and circular type as illustrated in figure 11.2 and 11.3. For large conduits access shafts are generally provided in circular shape and suitable size of openings to allow a workman with cleaning equipment without difficulty.

11.3.7.2 Construction of Manholes

The manholes shall be constructed simultaneously with the conduit line. The manholes shall have 20 mm thick cement plaster in cement mortar 1:3. The foundation of manholes shall be 15 cm thick cement concrete of appropriate grade and thickness may be increased to 30 cm when subsoil water is encountered, the projection of concrete being 10 cm on all sides of the external face of the brickwork. The floor of the manholes shall be in cement concrete of appropriate grade. Concrete half channel pipes of the required size and curve shall be laid and embedded in cement concrete base to the same line and fall as the conduit. Both sides of the channel pipes shall be benched up in concrete and rendered smooth in 20mm thick cement mortar and formed to a slope of 1 in 10 to the channel. Bricks on edge shall be cut to a proper form and laid around the upper half at all the pipes entering or leaving the manhole, to form an arch. All round the pipe there shall be a joint of cement mortar 12mm thick between the pipe and tile bricks. The ends of the pipes shall be built-in and neatly finished off with cement mortar. The masonry shaft or the manhole shall be provided on the top with a heavy airtight cast iron frame and cover conforming to IS:1726 or any other approved type of frame and cover. Where the depth of the manhole exceeds 90cm below the surface of the ground, steps of cast iron or of any other approved material shall be built into the brickwork. The distance between the two consecutive steps shall not be more than 40cm. The top at manhole shall be flush with the finished road level (IS: 4111 Part I - 1967 Manholes).

The entire height of the manhole shall be tested for water-tightness by closing both the incoming and outgoing ends of the conduit and filling the manhole with water. A drop in water level not more than 50mm per 24 hours shall be permitted. In case of high subsoil water, it should be ensured that there is no leakage of groundwater into the manhole by observing the manhole for 24 hours after emptying it.

11.3.7.3 Location of Manholes

Manholes are constructed at every change in alignment, gradient and size as well as at the start of all conduits and branches and at every junction of two or more small-size conduits. Nevertheless, junction chamber is a special design of underground chamber used to join two or more large storm water drain. This type of structure is usually required where storm drains are larger than the size that cannot be accommodated by standard manholes. Junction chamber by definition do not need to extend to the ground surface, however it is recommended that riser structure be used to provide surface access.

11.3.7.4 Spacing of Manholes

Criteria for the spacing of manholes have been developed in response to storm drain maintenance requirements. At a minimum, manhole should be constructed at the following points in storm drain system;

- a. Where two or more storm drains meet.
- b. Where pipe sizes change.
- c. Where the change in alignment occurs.
- d. Where a change in grade occurs.

In addition, manholes may be located at intermediate points along straight runs in accordance with the criteria mentioned in the following table. However individual agencies may have limitations on spacing of manholes due to maintenance constraints:

Table 11. 5: Recommended Maximum spacing of Manhole

Pipe size (mm)	Recommended maximum spacing (m)
300-600 diameter	40
700-1050 diameter	100
1000-1400 diameter	150
1500 and above diameter	300

Manholes should be constructed in accordance with standard drawings as required. Location of manholes in roadway reserves may be preferred as follows;

- I. Roadside
- II. Median strips
- III. Centre of road pavement

11.3.7.5 Drop-in Manhole

Where conduits of different characteristics are connected, transitions occur. The difference may be flow, area, shape, grade, alignment and conduit material with a combination of one or all characteristics. The vertical drop may be provided only when the difference between the elevations is more than 60 cm, below which it can be avoided by adjusting the slope in the channel and in the manhole connecting the two inverts. The following invert drops are recommended.

Table 11.6: Recommended invert Drop-in Manhole

S.No.	Diameter	Invert drop
1	For conduits less than 400mm	half the difference in dia
2	400mm to 900 mm	2/3 the difference in dia
3	Above 900 mm	4/5 the difference in dia

11.3.7.6 Shape and Size of the Manhole

Manholes are constructed directly over the centre line of the conduit. They are rectangular, circular or square in shape. They should be of a size that facilitates cleaning and inspection of conduits.

a. Rectangular Manhole

The minimum internal size of rectangular manhole between internal faces should be

- For depth less than 0.90 m, 900 mm × 800mm.
- For depth from 0.9 m and up to 2.5 m, 1200 mm × 900mm

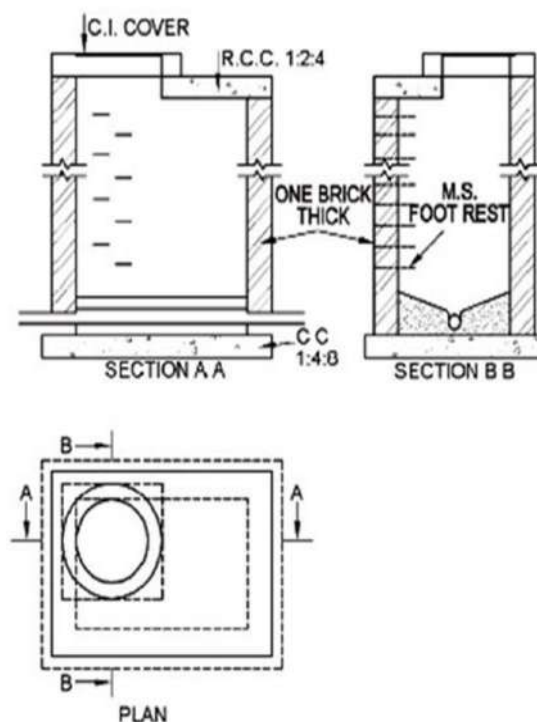

Figure 11. 2: Rectangular Manhole

b. Circular Manhole

Circular manhole is stronger and preferred over rectangular or square manholes. These can be provided for all depths from 0.9 m upwards. They are constructed straight down in a lower portion and slanted on top portion to narrow down the top opening so that it fits with the size of diameter of cover and frame as shown in the figure 11.3. The internal diameter of the circular manhole should be kept corresponding to the depth as follows:

- I. For depths above 0.9m and up to 1.65m – 900mm dia
- II. For depths above 1.65m and up to 2.30m- 1200mm dia
- III. For depths above 2.30 and up to 6.0m- 1500mm dia
- IV. For depths above 6.0m and up to 9.0m – 1800mm dia

The manhole should be oriented in a manner so that workers enter into it while facing traffic.

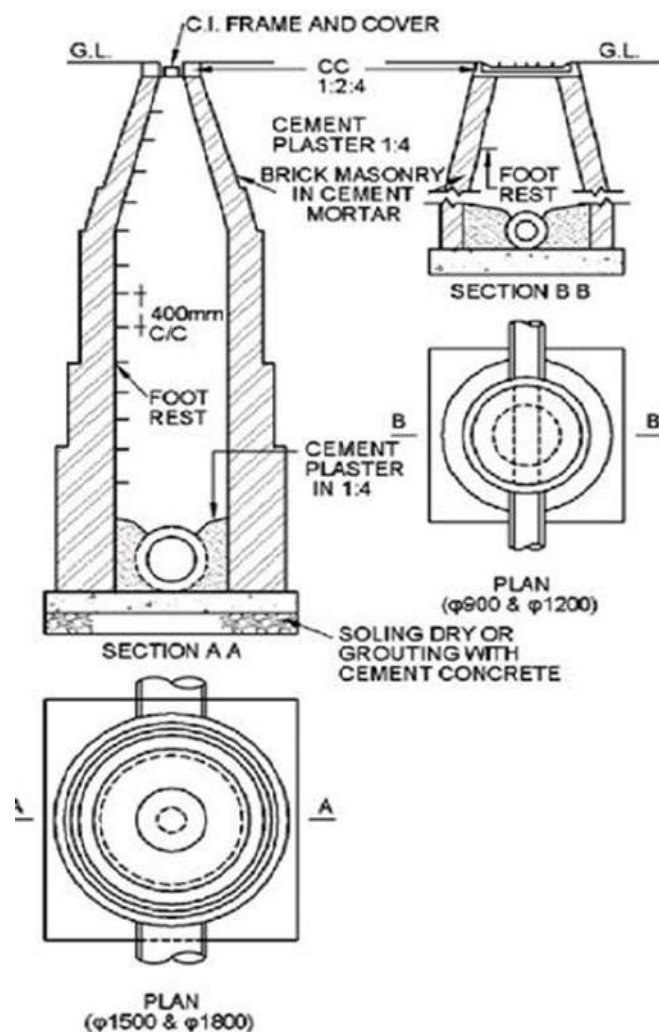

Figure 11. 3: Circular Manhole

c. Drop Manholes

Drop manholes are used to connect storm water drains at significantly different levels and should be used where the level difference is greater than 600 mm.

The drop manhole can be provided by means of

- A. Vertical drop in the form of a downpipe constructed inside/outside the well of manhole
- B. A gradual drop in the form of cascade or ramp
- C. A cascade is preferred for drain larger than 450 mm diameter. Downpipe is suitable for drains less than 400 mm diameter. When downpipes are used, the following recommendations are made:

- Proper anchoring of the downpipe at the bottom in the form of 90° pipe bend surrounded by concrete should be provided
- T branch at the top fitted with a flap valve inside the manhole should be made to avoid splashing

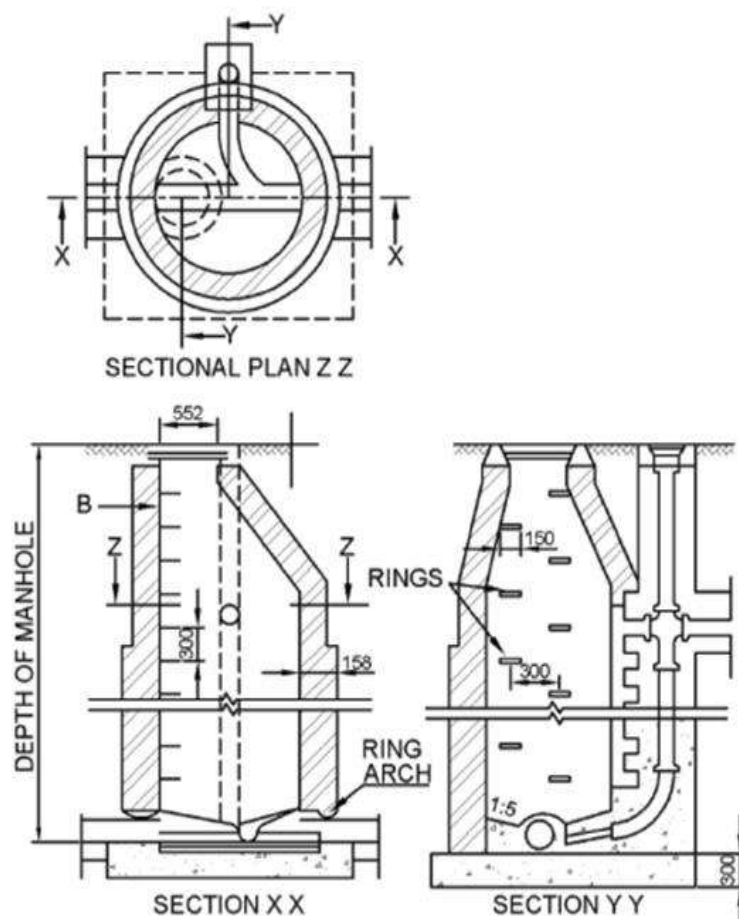

Figure 11. 4: Drop Manhole

11.3.7.7 Cover and Frame of Manhole

Manhole cover and frame are designed to provide adequate strength to support superimposed loads, provide a good fit between cover and frame. For safeguarding against unauthorised tampering, the manhole cover should be bolted or secured with some locking mechanism. The size of the manhole should be such that there is a clear opening of not less than 560 mm diameter when cast iron cover and frame is used. They should conform to IS 1726 (part 1-7). The frames of the manhole should be firmly embedded in correct alignment and level plain cement concrete on the top of the masonry. After completion of work manhole cover should be sealed by means of thick grease.

Heavy reinforced cement concrete cover with suitable lifting arrangement may also be used instead of C.I. manhole cover. Fiber-reinforced plastic covers (FRP) may be used wherever such covers are available.

11.3.7.8 Access Steps in Manhole

Steps are provided for conveniently accessing the floor of the manhole for inspection and cleaning. The steps should be corrosion resistant. Steps coated with epoxy or fabricated from rust-resistant material such as stainless steel or aluminium coated with bituminous paint are preferable. Steps made from reinforcing steel are not recommended. It is suggested by certain agencies to eliminate the use of steps with reason to avoid the danger of rust damages steps as well as unauthorised access to manhole. Besides, it is said that maintenance personnel shall use their own ladder for inspection or cleaning. The spacing of the steps should be maintained approximately 300-400mm and should be fixed staggered in order to have ease in ascent and descent. Cat ladder should be used in manhole deeper than 4.25 m or where manhole is frequently entered. Step iron and ladder should start at not more than 600mm below cover level and continue to benching.

11.3.7.9 Intermediate Platform

Manhole deeper than 4.25 m from the cover level should be provided with intermediate platforms at regular intervals. The headroom between platforms should not be less than 2.0 m. The size of the platforms should be 800 mm × 1350 mm. The platform should be fitted with handrail and safety chains at the edge to protect workers against falling down.

11.3.7.10 Inverts and benching

The inverts should be curved to the radius of the pipe and carried up in flat vertical surfaces and should match the cross-sections & bends and gradient of the respective storm water drains. The benching should be plain surface sloping gently down towards the drains. A gradient of the benching of 1 in 12 may be provided. The socket end of the pipe should be cut off and should not project inside the manhole.

The crown of the incoming and outgoing conduit should be kept at same level and necessary slope should be given in the invert drain of the manhole chamber preferably 1 in 10. The manhole should be safeguarded against uplift groundwater pressure as well as against entry of groundwater. U shaped small channels should be constructed integrally with concrete base of the manhole chamber to carry the flow in conduit. The side of channel should be kept equal to the diameter of the largest conduit. Where more than one conduit enters the manhole the channel should be smoothly curved to carry adequately the peak flow. The pipe joints should be kept outside the manhole chamber and the inlet and outlet pipe should be made flush with internal face of the manhole chamber. The inlet and outlet pipes built with the wall of the manhole should be properly protected with cement concrete cover round the pipes against crushing of wall loads. Inside and outside brick surface of manhole should be plastered 1:3 cement mortar and inside surface should be finished smooth with neat cement punning.

Whenever sub-soil water is encountered a rich mix of plaster with waterproofing chemical compound may be used.

11.3.7.11 Outfall Structure

Outfall conduit is supported with a brick wall generally of 425 mm thick in 1:3 cement mortar at the point of disposal to a river or stream. The outfall conduit should project 100 - 150 mm inside the bank of river/stream. To protect the bank against erosion, it is necessary to pave the bank 2 m on either side from the point of disposal with cement concrete block providing toe wall and apron to safeguard against slipping of revetment as well as the erosion of the bed of the river/stream.

11.3.7.12 Inverted Syphon

Inverted siphon or depressed pipe which should stand full even without any flow and shall run with pressure above atmosphere on account of being depressed below the hydraulic grade line. Its purpose is to carry the storm water flow under an obstruction such as a stream or depressed highway and to regain the permissible elevation after crossing the obstruction to maintain gravity flow or pumping whichever is feasible. Siphons can consist of single or multiple barrels however it is recommended that a minimum of two barrels should be provided as shown in the fig.11.5.

Following criteria may be considered in designing siphons

- a) Self-flushing velocities should be provided under a wide range of flows.
- b) Hydraulic losses should be minimized.
- c) Provisions for cleaning should be made.
- d) Sharp bends should be avoided.
- e) the rising portion of the siphon should not be made too steep as to make it difficult to flush deposits
- f) There should be no change in pipe diameter along the length of the siphon.
- g) Provision for drainage should be considered.
- h) Head should be sufficient to cover the entry, exit and friction losses and should develop not less 1.0 m/s self-cleansing velocity.
- i) Inlet and outlet chamber should have sufficient room for entry for cleaning and maintenance of siphons.
- j) Provision should be made for isolating the individual pipe of the siphon to facilitate cleansing.
- k) Proper bypass arrangement should be provided for inlet chamber.

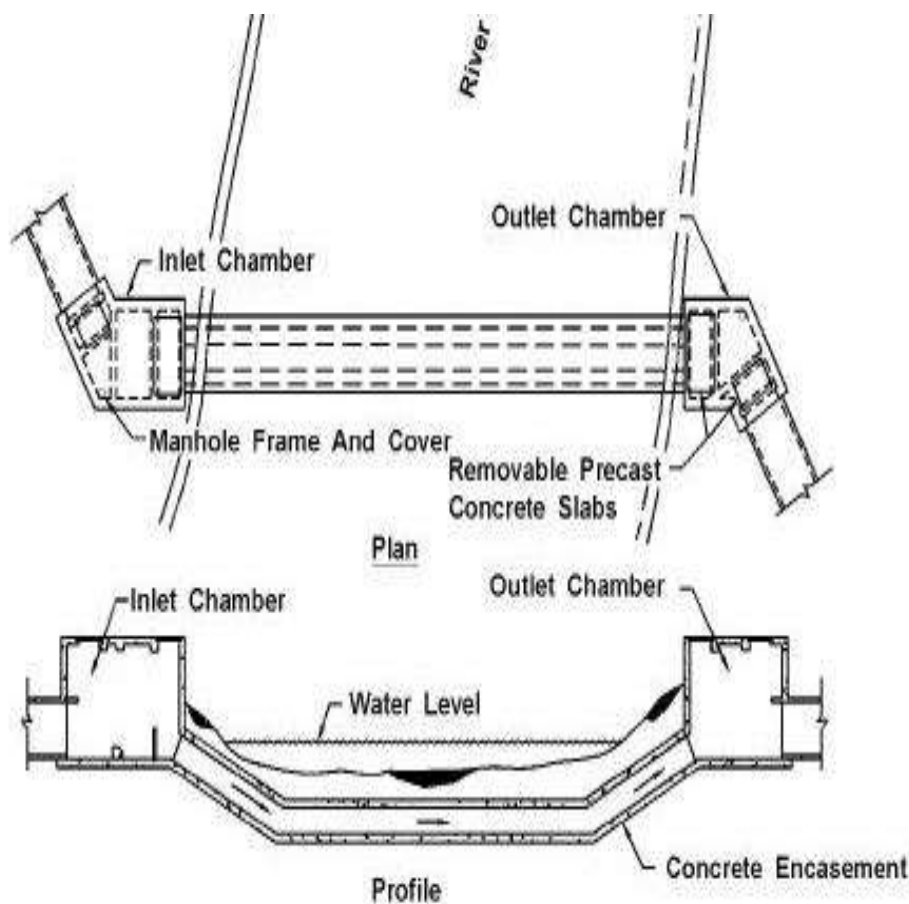

Figure 11. 5: Inverted siphon with minimum two barrels

11.3.7.13 Over Flow Device

At times it is needed to separate sewage flows from storm water either from a channel or pipe in order to divert the sewage flows to treatment plants instead of disposing with storm water that may cause hazardous pollution problem. Combined sewage systems are generally equipped with such overflow device to get rid of heavy storm water flow during wet seasons.

a. Leaping Weir

Leaping weir is the most common device that is formed by gap in the invert of a sewer through which the dry weather flow or sewage falls and over which portion of all storm water leaps over to overflow pipe. Leaping weirs have the advantage of operating as regulator without moving parts but they offer the disadvantage of depositing grit in the low flow channel. However it is desirable to design the weirs with moving crests to make the opening adjustable.

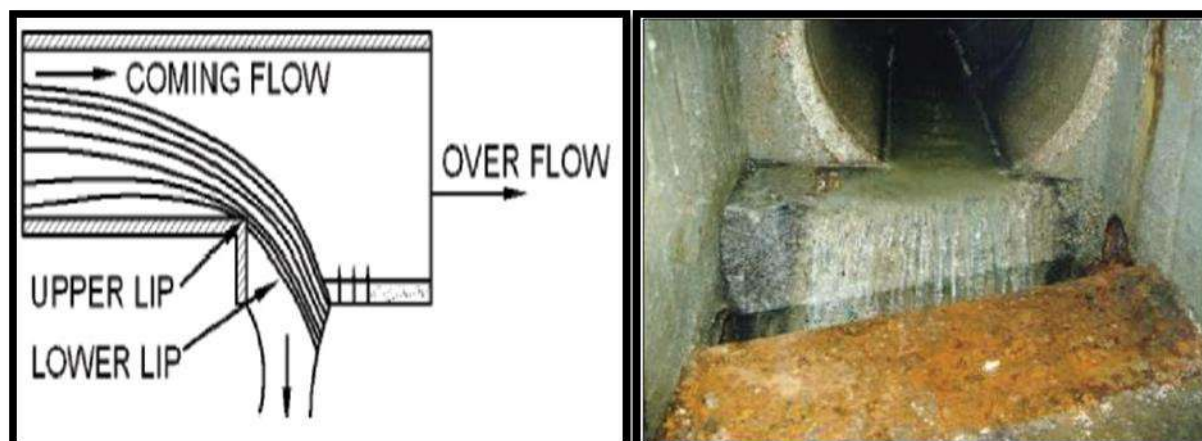

Figure 11.6: Leaping weir

b. Intercepting Conduits

The above device is invariably used to intercept sewage from storm flows and convey through intercepting conduits to waste water plants for treatment.

Delhi Jal Board has recently executed intercepting sewer project to intercept sewage from storm water drains flowing to Yamuna River in order to control heavy pollution of the river.

11.3.7.14 Multi-Functional storm and Sewer Drains

In most of new layouts the septic tank and open drains on road sides for storm water are a matter of routine and invariably the septic tank effluent is discharged into the drain which complicates the environmental hazard in rainy seasons. The twin drain system can stall the pollution by containing the septic tank effluents, which can be collected and provided with treatment in a decentralised manner. Till a sewer system is provided, this can be got solved in the interim period by adding one more drain integrally side by side of storm water drain and this serving as dedicated closed sewer. Further elaborate details can be seen in clause 8.4.4 in chapter 8 Decentralised Sewerage System in Part- A – Engineering, CPHEEO Manual on Sewerage and Sewage Treatment Systems 2013. For such new layouts, it will be useful if the bye-laws can be strengthened to mandate the twin drain instead of the roads drain alone, which is anyway mandated by the Town and Country planning act.

11.4 Storm water Open Channel

Storm water drains are surface drains which are constructed as open or covered drains with a suitable gradient to carry the storm water flows from the catchment to the safe disposal point. Drainage in the urban context is classified as given below:

Tertiary drains: In urban catchments, tertiary drains collect storm water from sub-zones and convey to the secondary drains.

Secondary drains: These drains collect storm water from tertiary drains and zones. They discharge the storm water into the primary drains.

Primary Drains: In urban catchments, primary drains are main drains that collect storm water from secondary drains and discharge to the safe disposal point.

11.4.1 Construction of Storm Water Drains

This section discusses the construction of surface drains such as tertiary, secondary and primary drains. The tertiary drains are generally small drains that are constructed in rectangular section whereas; secondary and primary drains are larger drains that are normally constructed in the trapezoidal section.

General preparation of works as given in section 11.3 should be followed as applicable. Drains are generally either of masonry or RCC construction. The general construction description of masonry and RCC drains are given as follows:

11.4.1.1 RCC drains

Tertiary drains are usually constructed in rectangular section either of masonry or reinforced cement concrete. Where it is proposed to construct precast RCC drain, the same should not be less than 50mm thick and should be reinforced with 3 longitudinal bars of 6mm diameter and 2 crossbars of same size in 0.6 m length and mould should be removed after 48 hours then they shall be kept well watered for a fortnight and after this watering shall be discontinued and the drain should be left to cure for another fortnight before laying. The ground should be kept to the exact shape and slope at which drains are to be laid and the trench will be watered and rammed.

11.4.1.2 Brick Drains

Brick drains can also be constructed of bricks. The brickwork shall be in cement mortar 1:3 and plastered smooth with cement plaster of 1:2, 20 mm thick. A change in the

alignment of the brick drain shall be on a suitable curve conforming to the surface alignment of the road.

11.4.1.3 Rectangular Section

In congested urban areas, small or medium drains are constructed in a rectangular section covered with suitable RCC slabs to protect against dumping of solid waste from the local residents. Rectangular drains are normally constructed in hilly regions due to space crunch.

11.4.1.4 Trapezoidal section

Primary and secondary drains that normally carry a considerable quantity of storm flows are constructed in trapezoidal section. Especially outfall channels that sometimes carry entire storm flows from the catchment are designed in larger sections that often resemble irrigation channels. In such cases it is preferable to economize the cost by constructing earthen channels with cement concrete lining.

11.4.2 Kerb and Gutter

Gutters are provided at both edges of pavement all along the length for collecting rainwater from the pavement. They are constructed in triangular section and are generally in RCC. The details of gutter design are given in Chapter 5.

11.4.3 Construction Procedures of Storm Water Drains

The construction of storm drains is described as follows.

Step1: Marking of Alignment - The surveyor marked out the alignment for the trench to be dug.

Step 2: Digging/Excavation - The surveyor marks out the depth and width of the trench as per size and design requirement to be excavated with a mechanical excavating machine.

Step 3: After excavation concrete blinding is done - Blinding is done on the surface area in order to correct any irregularities in the level of the bed of the excavated surface, and to provide a smooth, level and regular surface to receive the concrete base. It's usually ± 50 mm depending on the rate of regularity of the surface area. The blinding is a mass concreting and it's advisable to spread to cover entire width of the excavated trench.

Step 4: Reinforcement (iron Rod) positioning - Reinforcement (spaced as designed) is placed into position on the blinded surface but positioned at the centre of

the base with the aid of concrete biscuit to create a concrete cover. There should be 25 – 30 mm concrete cover between the reinforcement and the base.

Step 5: Laying of concrete base on the blinded surface and the positioned reinforcement - A guiding panel is placed into position to for laying of the concrete base in order to achieve uniform alignment base edge, thickness and width, and also to manage concrete material while pouring. The base is cast with the U shape reinforcement bottom in between the concrete base achieving concrete cover below and above.

Step 6: After setting and drying of the concrete base, next is to position the side wall panel formwork - The floor base is marked to give the required internal width where the panel will be positioned. The panel wall spacing and wall height is as per requirement of design; the panel is lubricated, clipped and prepared to accept the Concrete. After casting, and setting, the panel is removed and concrete cured.

Step 7: In order to avoid settlement, backfilling and compaction of the backfilling should done immediately

11.4.4 Covering of Drains

Secondary and tertiary drains constructed in congested sectors of the urban area should be covered with precise RCC slabs of suitable size wherever needed. RCC Slabs in smaller lengths capable of lifting by 1 – 2 persons are precast with lifting hooks. After proper curing these slabs are placed over the drain and joined with cement plaster. When the drains are required to be cleaned, these slabs can be removed easily at suitable intervals and cleaning operation can be done. Even secondary and primary drains of larger section, it will be uneconomical to cover them instead they can be fenced along their edges or small parapet may be constructed to protect children or men falling in them. However, if resources permit ULB may undertake to cover such drains if it is deemed expedient in favour of public welfare.

11.4.5 Box Drains

RCC box drains are constructed along drainage reserve of heavy vehicular traffic. These drains are designed to withstand vehicular load and carry the large storm water volume to the safe disposal point. Street inlets are provided between 15 – 30 m interval in order to admit storm water in the box drain. They are laid 200 – 300 mm below ground level in suitable gradient having access holes



Figure 11. 7: Box drain

at an interval of 30 m to facilitate cleaning etc. A typical figure of a box drain is shown in figure 11.7.

11.5 Drainage standards of Flyovers

The entire rainwater on the carriageway of flyover should be drained through efficient down take pipes or pipes embedded in piers to the adjacent drains constructed below on the pavement. The size of pipe may be designed according to storm runoff with minimum pipe size of 100 mm. Caution should be exercised not to allow straight drop of water from flyover to road surface below, which results in disruption of traffic and damage to road pavement.

11.5.1 Drainage at Foot of Flyovers

The longitudinal gradient of a ramp of flyovers is usually up to 3 percent or even more and the cross slope will be about 2 percent. The majority of rainwater flows rapidly in longitudinal direction rather than cross slope resulting in very large quantity of water reaching the valley curve area where it meets ground-level road. This junction should be provided with finger plate drain across the pavement. The valley junction should be engineered in such a way that even below road pavement should have downward longitudinal gradient towards valley junction, so that entire rainwater from flyover can be efficiently discharged into the drain at the edge. The estimated runoff for design of the drains section can be calculated using Rational formula for a given design rainfall intensity.

11.6 Vehicular Subways

Drainage of vehicular subways should be efficiently planned at its conception stage itself. Most preferable system of drainage shall be by gravity. The entire surface drain of subway should be taken to the lowest level and a suitable grating provided across full width of road. Typical subway drainage is shown in Figure 11.8. The grating should have a disposal chamber which will collect the storm water and dispose it to the nearby storm water drain either by gravity or by pumping if required. In case of larger subways, two inlets can be provided at both ends of box-approach ramp junctions. The gratings shall be at least 10 m away from the deck to minimize ascending water during rains in the box portion. The estimated runoff for



Figure 11. 8: Subway Drainage

design of the drains section can be calculated using Rational formula for a given design rainfall intensity.

11.7 Culverts

Some regions along plain consist of vast flat without any deep and defined drainage channels in it. When the rain falls, the surface water moves in some direction in a wide sheet of nominal depth. So long as this movement of water is unobstructed, no damage may occur to property or crops. But when a road embankment is thrown across the country intercepting the natural flow, water ponds up on one side of it. Relief has then to be afforded from possible damage from this ponding up by taking the water across the road through causeways or culverts. In such flat regions, the road runs across wide but shallow dips and, therefore, the most straightforward way of handling the surface flow is to provide suitable dips (i.e., causeways) in the longitudinal profile of the road and let water pass over them. After we have decided that a culvert has to be constructed on a road lying across some such country, we proceed to calculate the discharge by using one of the runoff formulae, having due regard to the nature of terrain and the intensity of rainfall

Culverts may be required over wide storm water channels 6 m wide or less across road alignments wherever necessary. Design and construction of such culverts may be referred to IRC SP:13-2004 'Guidelines for the Design of Small Bridges & Culverts'.

11.8 Safety and Social Safeguard

The need for safety precautions in any specific project area must be recognized and observed before and during construction activities. The following care should be taken:

1. Any construction will draw onlookers, especially children. Onlookers should be kept away from the operating equipment and from the edges of excavations.
2. Traffic must be diverted and or controlled at all times unless permission has been received from the proper authority to completely close a road or divert the traffic.
3. Emergency vehicles must not be delayed.
4. Vehicular access to homes and places of business should be maintained. If this is not possible, the occupant should be apprised of the situation by the Contractor or the Engineer. It is an absolute necessity that good relations be maintained with the general public.
5. When leaving the project at night, no unnecessary obstructions to traffic should be left behind, such as earth lumps from the trench excavation or sections of pipe that encroach on the roadway.
6. All necessary barricades for the construction close to traffic need to be made.

7. Provision of warning signs 150 meters in advance of any place on the project where the operations interfere with the use of the road by crosses or coincides with an existing road.
8. The construction area of the project should be properly lighted.

a) Signs, Signals, and Barricades

- I. Before starting any job in a street or other traffic area, study the work area and plan your work
- II. Traffic may be warned by high-level signs well ahead of the job site
- III. Traffic cones, signs or barricades to be arranged around the work, and signboards to direct the traffic
- IV. Whenever possible place your work vehicle between the working site and the oncoming traffic
- V. Use fluorescent jacket while working along roads
- VI. Construction area should be barricaded so that unauthorized persons especially children may not enter within the construction site. Light signals should be placed also during night time

11.9 Completion of Works

1. The administrative Department/Ministry shall be kept informed at regular intervals about the stages of progress of work so that the client's observations, if any, could be responded to before the work is completed.
2. On completion of the work, the Administrative Department/Ministry should be intimated of the same and formal handing over arranged in writing. Reasonable advance intimation of completion of the work should be given to the concerned Department to enable them to make arrangements for taking over.
3. Completion plans of the project, including all services, should be prepared and submitted along with the completion report showing the expenditure incurred on the project.

11.10 Procedures for Handing Over

On satisfactory completion of works a joint inspection should be carried out to ensure that works are completed in accordance with the standard design and maintenance requirement laid down in this manual. Before the issue of completion certificate, a handing over inspection report should be submitted ensuring that all outstanding works

are completed. Within three months of issue of completion certificate and prior to the end of maintenance period a joint inspection should again be carried out to check if further works are required and that all outstanding or remedial works have been completed. Besides, during the planning and design stages a design memorandum should be prepared so that design parameters, handing over requirement or partial handing over arrangements of large projects can be agreed by maintenance authorities. If unforeseen problems are encountered during construction and changes have to be made, the maintenance authority should be consulted so that the changes may be incorporated. On completion changes made should be incorporated in the design memorandum before handing over charge of completed works. Reference may also be made to project administrative procedures and the relevant technical memoranda if any, for details of handing over and taking over procedures.

11.10.1 Procedure for handing Over in Dry Conditions

All conduit lines, channels and culverts, etc. to be handed over should be inspected in dry conditions wherever possible. In the case where the pipes, culverts or channels have to be commissioned prior to handing over (e.g. due to the requirement to maintain the existing flow or staged completion) and a temporary diversion of flow is not feasible, an additional inspection should be arranged prior to the commissioning. In certain circumstances, closed-circuit television (CCTV) survey of the pipes and internal faces of the manholes showing each connection pipe before commissioning can be adopted as an alternative to the joint inspection but prior agreement with the respective operation and maintenance authorities may be obtained.

11.10.2 Handing over Drainage Records

After handing over the works as per procedures outlined, the following documents should be submitted as soon as possible, but no later than 3 months under any circumstance:

- a) As-built drawings, in hard-copy and electronic format, if applicable
- b) Hydraulic and structural design calculations, in electronic format, if available
- c) Construction records including major acceptance tests, material quality records, product specifications and warranties
- d) O & M manual and system manual
- e) Maintenance manual for slope embankment
- f) Inventory of the drainage system with suitable numbering for the various parts of the system on GIS platform

In the event that as-built drawings are not available at the time of the handing over inspection, marked-up prints of the working drawings showing the final amendments

and the extent of works to be handed over should be provided. Records of material quality and acceptance tests should also be available for scruti

REFERENCES

1. Engineering Hydrology by K. Subramanya, Fourth Edition, McGraw-Hill,
2. Applied Hydrology by Ven Te Chow, David R. Maidment, Larry. W. Mays. McGraw-Hill, 1988
3. Central Water Commission, Water Resources of India, CWC Pub No. 30/88, CWC, New Delhi, India 1988
4. Hydrology for Engineers by Linsley, R K et al, McGraw-Hill (1958)
5. Handbook on the principles of hydrology by Donald M. Gray, 1970
6. Central Water Commission, Water Resources of India, Manual on Estimation of Design Flood, 2001
7. United States. Army. Corps of Engineers 'Flood Hydrograph analysis and computations, 1959
8. Textbook on Operation & Maintenance of Sewerage Works by Department of Civil engineering, IIT Roorkee
9. IWRRC Technical Reports, A Program In Urban Hydrology, Part li: An Evaluation Of Rainfall-Runoff For Small Urbanized Watersheds And The Effect Of Urbanization On Runoff by P. B.S. Sarma, J. W. Delleur, A. R. Rao, 1969
10. Basic concepts of kinematic-wave models, Professional Paper 1302 By: J.E. Miller, 1984
11. Statistical Methods in Hydrology, Book by C. T. Haan, 1977
12. Engineering Hydrology by K. Subramanya, Third Edition, McGraw-Hill,
13. Sturm, T. W., "Open Channel Hydraulics". International Edition, 2nd Edition, McGraw-Hill, 2010.
14. Henderson, F.M. "Open Channel Flow" Macmillan Co, 1966.
15. United States. Army. Corps of Engineers "Hydrologic and Hydraulic Analysis"
16. Buried Pipe Design, 2nd Edition (McGraw-Hill Professional Engineering) by A. P. Moser, 2001
17. IRC:SP:50-2013. Guidelines on Urban drainage
18. Low Impact Development, design manual for urban areas, University of Arkansas Community Design Center, Fayetteville, North Carolina, United States.
19. A.P. Moser, R.K. Watkins, and R.R. Bishop, "The Structural Response of Buried PVC Pipe" , Utah State University, 1972

20. Handbook of PVC pipe Design and Construction, by Uni – Bell, 2012
21. Sediment problems in urban areas, Circular 601- E, By: Harold P. Guy, 1970
22. Mahoning Country, Drainage & Erosion and Sedimentation Control Manual
23. Urban Drainage Design Manual by Federal Highway Administration, Second Edition, 2001
24. Storm Water Drainage Manual, City of Columbus, Ohio, 2006
25. A conceptual guidelines on Planning and Design of Drainage in hilly Area, IIT Guwahati, 2012
26. Storm Water and Crossings, Tasmanian Coastal works Manual
27. Virginia Erosion and Sediment Control field manual Virginia DEQ 1995
28. Design and Construction of sanitary and storm sewers – Water Pollution control Federation Washington DC USA
29. Hydraulic Manual of Texas Highway Department
30. Handbook for flood protection anti erosion and river training works, C.W.C Govt. of India
31. Developing Improved methodologies for MSL Trend examination by P. Watson University of New Southwards
32. Sea level change along the Indian coast by A.S. Unikrishnan & others
33. Sea level change along Indian coast Impacts & vulnerability A. S. Unikrishnan, National Institute of oceanography Goa
34. A study on regional sea level variation along the Indian coast by Piyali Choudhary, Dr. Mnasa Raiyari Behra
35. Code of Practice on Surface water Drainage, Singapore, Dec 2011
36. Storm Drainage Manual, Govt. of Hong Kong, 2000
37. Urban Storm Water Management Manual for Malaysia, MSMA 2nd Edition
38. Drainage Manual, State of Florida, Department of Transportation, 2008
39. Queensland Urban Drainage Manual, Third Edition, 2013
40. Drainage Manual, The South African National roads Agency Limited, 5th Edition, 2006
41. IRC SP 050: Guidelines on Urban Drainage (First Revision), 2013
42. Planning criteria for Water Sensitive Urban Design M. I. Rodríguez, M. M. Cuevas, G. Martínez & B. Moreno; Department of Urban and Regional Planning, University of Granada, Spain, Department of Construction and Engineering Projects, University of Granada, Spain Department of Urban and

- Regional Planning, University of Granada, Spain Department of Construction and Engineering Projects, University of Granada, Spain
43. Publication O FHWA – NH 1 -0 -096 June 2008 Hydraulic Engineering Circular No 25 Up Dept of Transportation Federal Highway Administration
 44. Storm Water Guidelines EPB 322, January 2014
 45. www.susdrain.org
 46. IS Code 16098 (Part I), 2013 - Structured-Wall Plastics Piping Systems for Non-Pressure Drainage and Sewerage — Specification
 47. IS Code 16098 (Part II), 2013 - Structured-Wall Plastics Piping Systems for Non-Pressure Drainage and Sewerage — Specification
 48. Rain water Harvesting and Conservation Manual, CPWD, MoHUA, Govt. of India, July 2019
 49. Manual on Artificial Recharge of Ground Water, CGWB, Ministry of Water Resources, Govt. of India, September 2007
 50. Water Sensitive Urban Design in the UK –Ideas for built environment practitioners - a scoping study (CIRIA project RP976)
 51. Low-Impact Development Design Strategies, An Integrated Design Approach, Prepared by: Prince George’s County, Maryland Department of Environmental Resources Programs and Planning Division, June 1999
 52. National Disaster Management Guidelines, Govt. of India, 2007
 53. Open Channel Hydraulics by Ven Te Chow, 2009
 54. CPHEEO, MoUD, “Manual on Sewerage and Sewage Treatment”, (1993)
 55. CPHEEO, MoUD, “Manual on Sewerage and Sewage Treatment”, (2013)
 56. CPHEEO, MoUD, “Manual on Water Supply & Treatment”, (1999)
 57. Low Impact Development Handbook “Stormwater Management Strategies” Department of Public Works, 2014
 58. UDOT Storm water Quality Design Manual, June 2018
 59. SUDS, or Sustainable Drainage Systems, published by CIRIA (2007)
 60. Water Sensitive Urban Design Technical Manual, Greater Adelaide Region, Technical Manual – July 2009

APPENDICES

CONTENTS

APPENDIX A 2.1	A-1
CHECKLIST FOR SUBMISSION & SCRUTINY OF DETAILED PROJECT REPORT	A-1
APPENDIX A 4.1	A-25
EXAMPLE ON PARTIAL AREA EFFECT.....	A-25
APPENDIX A 4.2	A-28
EXAMPLE ON TIME-AREA-METHOD	A-28
APPENDIX A 4.3	A-31
EXAMPLE ON UNIT HYDROGRAPH METHOD.....	A-31
APPENDIX A 5.1	A-35
EXAMPLE ON CRITICAL DEPTH.....	A-35
APPENDIX A 5.2	A-37
DETAILS OF STANDARD SIZED STEPPED CHANNELS.....	A-37
APPENDIX A 5.3	A-39
GEOMETRIC ELEMENTS FOR CIRCULAR CHANNEL SECTIONS.....	A-39
APPENDIX A 5.4	A-44
VALUES FOR COMPUTATION OF CRITICAL DEPTH IN TRAPEZOIDAL CHANNEL	A-44
APPENDIX A 5.5 (A)	A-46
NOMOGRAM FOR MANNING'S FORMULA.....	A-46
APPENDIX A 5.5 (B)	A-47
NOMOGRAM FOR MANNING'S FORMULA.....	A-47
APPENDIX A 5.5 (C)	A-48
NOMOGRAM FOR HAZEN WILLIAMS FORMULA.....	A-48
APPENDIX A 5.5 (D)	A-49
NOMOGRAM FOR HAZEN WILLIAMS FORMULA.....	A-49
APPENDIX A 5.6	A-50
MOODY DIAGRAM FOR OPEN CHANNEL FLOW	A-50
APPENDIX A 5.7	A-51
MANNING'S ROUGHNESS COEFFICIENT FOR OVERLAND FLOW.....	A-51
APPENDIX A 5.8	A-52
EXAMPLE ON DESIGN OF STORM WATER DRAINS.....	A-52
APPENDIX A 5.9	A-54
SWMM MODEL DESCRIPTION AND CASE STUDY	A-54

APPENDIX A 2.1
CHECKLIST FOR SUBMISSION & SCRUTINY OF DETAILED PROJECT REPORT
(STORM WATER DRAINAGE) (SWD)

(to be filled in and certified by the highest city –level Officials, both technical and administrative, such as Chief Engineer/City Engineer/ Municipal Commissioner)

Instructions:

1. The DPR shall be formulated as per the guidelines are given in Manual of Storm Water Drainage Systems published by the Ministry and as per the Department procedures.
2. DPR shall be technically sanctioned by the Competent Authority the State Govt./ULB before forwarding it to the Ministry.
3. Each and every page has to be signed at the bottom by the officials.
4. Each field has to be filled in appropriately as 'yes', 'no', 'not required', 'not done', 'not used' etc. No field has to be left blank. Give explanatory comments wherever 'no' is indicated.
5. Non- definite entries such as 'will be done later', 'will be furnished later' etc. will not be accepted.

CERTIFICATE:

This is to certify that the undersigned have read the contents of the checklist fully and have responsibly made the entries true to the best of knowledge and understanding. In case the information furnished in the checklist enclosed is found to be incorrect for any reason, whatsoever, the undersigned may be held liable for disciplinary action as per applicable Government rules.

Certified that

- (i) The designs and drawings have been approved by the Competent Authority.
- (ii) The detailed estimates and cost estimates are as per the current schedule of rate and/or rate analysis and latest Pro-forma invoices (current market rates).
- (iii) The DPR has been technically sanctioned by the Competent Authority in the State Govt./ULB.

Signed:
Name:

Signed:
Name:

CHECKLIST FOR SUBMISSION & SCRUTINY OF DPR
(STORM WATER DRAINAGE SYSTEM)

S. No	Description	Write 'Yes' or 'No' etc. in the column below
		If Yes, give Page No./DPR volume reference. If No, reasons thereof
1. GENERAL COMPONENTS		
1.1	Name of the town/city/District/State for which scheme has been formulated with name of the scheme (a) Name of the City/Town: (b) Name of the District: (c) Name of the State : (d) Name of the Scheme:	
1.2	Date of DPR appraised by State Level Nodal Agency (SLNA) and whether a copy of appraisal report (duly authenticated by the competent authority) has been forwarded with DPR. (a) Date of appraisal: (b) Name of the appraisal agency: (c) Original Estimated cost: (d) Appraised cost: (e) Major comments/observations made by appraisal agency.	
1.3	Whether the commitment to launch the scheme immediately after approval of Govt. of India / Administrative approval of the scheme is appended in DPR.	

S. No	Description	Write 'Yes' or 'No' etc. in the column below
		If Yes, give Page No./DPR volume reference. If No, reasons thereof
1.4	(a) Whether Project formulation justification (need for the project) has been furnished in DPR. Please justify the need of the project. Justification: (b) Whether the executive summary of the project is furnished in the DPR	
1.5	Whether linkages of this scheme have been established with other ongoing Storm water drainage schemes being funded by the Central/State Govt./other agencies if any. Please furnish the details.	
1.6	Whether the map showing administrative and political jurisdiction of the project area has been given in DPR. The area within Municipal limit : sq.km. The extent of area considered in the DPR :sq.km. Additional area (beyond Municipal limit) considered in the DPR and justify the reasons:sq.km	
1.7	Whether the land use pattern of the city/town/ project area as per the approved Master Plan has been given in DPR.	
1.8	Whether the DPR including the design, drawings, cost estimates, analysis of rates has been authenticated by Competent Authority of State Govt./ ULB and Quasi-Technical sanction of DPR / Technical & Financial Verification Certificate has been attached with DPR	
1.9	In case any proposed pumping main for storm drainage lines is crossing Railway line/ Highway & their bridge (wherever applicable), whether the clearance from concerned authority such as State Pollution Control Board (SPCB), Highways, PWD, Railways has been obtained and copies of the permission and their estimate for the same has been provided in DPR. If not, the present status of action initiated may be furnished below.	

S. No	Description	Write 'Yes' or 'No' etc. in the column below
		If Yes, give Page No./DPR volume reference. If No, reasons thereof
1.10	Whether the provision for separate electric feeder line to the storm water pumping stations (to take care of frequent power failure and voltage fluctuation problem) from HT line and an agreement between Electricity Department and Urban Local Bodies (ULBs) has been furnished in the DPR	
1.11	Whether the commitment from the Electricity Department for un-interrupted power supply (for pumping stations) is obtained	
1.12	Whether the topographic map of the city/town/project area on GIS has been given in DPR/Zone wise maps to scale showing all streets.	
1.13	Whether soil investigation report – borehole logs at least at a grid of 1 km x 1 km or Geological Survey Data has been forwarded with DPR.	
1.14	Whether Contour map of the project area has been annexed with the DPR.	
1.15	Whether resolution from the ULB for meeting the regular expenditure on O&M of the storm water drainage system is enclosed in DPR.	
2. ENGINEERING COMPONENTS		
2.1	Storm water drainage network detailing	
	<p>The total length of drain & other infrastructure (Total length and drains which are in good condition and can be integrated with proposed planned drainage system):</p> <p>Tertiary drain :Km (total)KM (drains in good condition) Secondary drain :Km (total)KM (drain in good condition) Primary drain :Km (total)KM (drain in good condition) SWD Pumping Stations: Nos..... Capacity of Pumps.....Length of Pumping Mains..... Km</p> <p>Proposals for Rehabilitation Tertiary drain :Km</p>	

S. No	Description	Write 'Yes' or 'No' etc. in the column below
		If Yes, give Page No./DPR volume reference. If No, reasons thereof
	Secondary drain :Km Primary drain :Km SWD Pumping Stations: Nos..... Capacity of Pumps.....Length of Pumping Mains..... Km	
	Proposals for new construction Tertiary drain :Km Secondary drain :Km Primary drain :Km SWD Pumping Stations: Nos..... Capacity of Pumps.....Length of Pumping Mains..... Km	
2.2	Total length of road :Km	
2.3	Please furnish various project components (major components)	
2.4	Project Area and population (i) Please furnish the details of city/project area, (a) Area of the town/city (municipal limit):Sq. km (b) Extent of the project area considered in the DPR:sq. km (c) Additional Area(beyond the municipal limit) considered in the DPR:.....sq.km (d) No. of Households (as per 2001 and 2011 census): (ii) Whether population projection has been adopted as per CPHEEO Manual and given in DPR	

S. No	Description	Write 'Yes' or 'No' etc. in the column below If Yes, give Page No./DPR volume reference. If No, reasons thereof
	<p>(a) City population</p> <p>As per 2001 Census :.....lakhs As per 2011 Census :lakhs Initial stage : lakhs +floating population (if any)-----lakh (.....AD) Intermediate stage : lakhs+ floating population (if any)-----lakh (.....AD) Ultimate stage : lakhs+ floating population (if any)-----lakh (.....AD)</p> <p>Population growth rate adopted: %/ year (based on the past 5-6 decadal growth rate) Demographic Method adopted and justification :</p> <p>(b) Whether the population projection has been made in consonance with the Developmental Master Plan</p> <p>(c) Project Area</p> <p>Initial stage : lakhs Intermediate stage : lakhs Ultimate stage : lakhs Population growth rate adopted: %/ year (based on the past 5-6 decadal growth rate)</p> <p>(d) No. of wards (within municipal limit) :</p>	

S. No	Description							Write 'Yes' or 'No' etc. in the column below	
								If Yes, give Page No./DPR volume reference. If No, reasons thereof	
2.5	Whether the development master plan with land use pattern, identification of existing and future roads/streets, water bodies such as lakes and ponds, natural drains and rivers has been furnished for the urban agglomeration								
2.6	If yes, give the master plan year. If no, give present status of master plan preparation;								
2.7	Land use patterns, present and proposed preferably on shapefile format								
	Land Use		Master Plan		City/ULB Area		Project Area		
			Present Master Plan: Year	Proposed Master Plan: Year	Present Area (Year)	Proposed Area (Year)	Present Area (Year)		Proposed Area (Year)
	Total Area	Hectares (Ha)
		%	100%	100%	100%	100%	100%		100%
	Residential area	Ha							
		%							
	Area under Roads >3m wide	Ha							
		%							
	Area under Roads & streets <3 m wide	Ha							
%									
	Ha								

S. No	Description								Write 'Yes' or 'No' etc. in the column below
									If Yes, give Page No./DPR volume reference. If No, reasons thereof
	Markets (wholesale, vegetable, grain, other	%							
	Area under Railways, Airports	Ha							
		%							
	Institutional Area	Ha							
		%							
	Industrial Area	Ha							
		%							
	Green, open, park, an agricultural area	Ha							
		%							
	Lakes, Ponds	Ha							
		%							
	Natural drains, sub-drain, nallahs, rivers	Ha							
		%							
Give Coefficients of Imperviousness adopted for design for various land uses:									

S. No	Description			Write 'Yes' or 'No' etc. in the column below
				If Yes, give Page No./DPR volume reference. If No, reasons thereof
	Land use classification	Coefficient of Imperviousness as per Manual / Derived	Coefficient of Imperviousness as per DPR	
	Residential	0.60 to 0.75		
	Roads, paved surface of footpaths	1.00		
	Commercial	0.70 to 0.90		
	Paved markets	1.00		
	Unpaved markets	0.40 to 0.70		
	Mixed type markets	0.40 to 0.90		
	Mixed Development	0.60 to 0.90		
	Industrial	0.60 to 0.90		
	Institutional	0.60 to 0.90		
	Large establishments			
	PSUs	0.60 to 0.90		
	Railways	0.60 to 0.90		
	Airports	0.60 to 0.90		
	Lakes, ponds	1.00(considering FSL)		

S. No	Description	Write 'Yes' or 'No' etc. in the column below																											
		If Yes, give Page No./DPR volume reference. If No, reasons thereof																											
2.8	<p>List out all-natural drains in the city/project/master plan area. Give the names (IDs) and length Natural storm water drains preferably on GIS maps (use additional sheets if required):</p> <table border="1"> <thead> <tr> <th>S No</th> <th>Name / ID</th> <th>Length, Km</th> </tr> </thead> <tbody> <tr><td> </td><td> </td><td> </td></tr> <tr><td> </td><td> </td><td> </td></tr> <tr><td> </td><td> </td><td> </td></tr> <tr><td> </td><td> </td><td> </td></tr> <tr><td> </td><td> </td><td> </td></tr> <tr><td> </td><td> </td><td> </td></tr> <tr><td> </td><td> </td><td> </td></tr> <tr><td> </td><td> </td><td> </td></tr> </tbody> </table>	S No	Name / ID	Length, Km																									
S No	Name / ID	Length, Km																											
2.9	<p>Give width-wise detailing of natural storm water drains (use additional sheets if required):</p> <table border="1"> <thead> <tr> <th>S No</th> <th>Width</th> <th>Length, Km</th> </tr> </thead> <tbody> <tr> <td> </td> <td>Upto 2m</td> <td> </td> </tr> <tr> <td> </td> <td>>2m upto 5m</td> <td> </td> </tr> <tr> <td> </td> <td>>5m upto 10m</td> <td> </td> </tr> <tr> <td> </td> <td>>10m upto 30m</td> <td> </td> </tr> <tr> <td> </td> <td>>30m (give further widths if necessary)</td> <td> </td> </tr> </tbody> </table>	S No	Width	Length, Km		Upto 2m			>2m upto 5m			>5m upto 10m			>10m upto 30m			>30m (give further widths if necessary)											
S No	Width	Length, Km																											
	Upto 2m																												
	>2m upto 5m																												
	>5m upto 10m																												
	>10m upto 30m																												
	>30m (give further widths if necessary)																												
2.10	<p>Whether the storm water drainage network has been divided into basins, sub-basins, catchments and overlaid on the development master plan? Give details.</p>																												

S. No	Description	Write 'Yes' or 'No' etc. in the column below If Yes, give Page No./DPR volume reference. If No, reasons thereof		
2.11	Demarcating of zones and subzones as per the map of the project area (use additional sheets if required):			
	Whether the Master Plan Area/Project Area has been divided into catchments and sub-catchments for Storm Water Management	Yes/No		
	Total no. of catchments (storm water drainage Zones)			
	Name/No. of catchment (zones)	1	2	3 etc
	Area under catchment (various zones), Ha.			
	No. of sub-catchments (sub-zones) under each zone			
	Describe boundaries of each catchment (use separate pages) Ridge/Road/Rly. Line etc.			
	Give name/no. of each sub-catchment, its boundaries and arial extent (use separate pages)			
	Give land-use classification for each catchment and sub-catchment with totals ((use additional sheets if required))			
Whether Catchment areas which are out of municipal limit likely to contribute in the project area has been taken into account				
2.12	Details of each sub-catchment (use additional sheets if required):			
	Name/ID No of sub-catchment			
	Total area			
	Define boundaries			
	Land use classification			

S. No	Description		Write 'Yes' or 'No' etc. in the column below
			If Yes, give Page No./DPR volume reference. If No, reasons thereof
	Area under..... Residential		
Roads etc.		
Institutional		
Industrial		
Lakes/Ponds		
Any other (add rows)		
	Total of above		
	Name/ID of the main drain of sub-catchment		
	Total length of the main drain		
	Width-wise length of the main drain (proposed)		
	<2m		
	>2m – upto 5m		
	>5m- 10 m		
	>10m-30m		
	>30m		
	Total of above		
	Whether boundary of main drain demarcated and protected	Yes/No	
	Length of main drain protected		
	Length of main drain not protected		
	Action, if any for full protection		
	Whether drain outfall free or obstructed?		
	Invert level of drain outfall		
	Invert at outfall		

S. No	Description	Write 'Yes' or 'No' etc. in the column below																																						
		If Yes, give Page No./DPR volume reference. If No, reasons thereof																																						
	<table border="1"> <tr><td>at + 30m</td><td></td></tr> <tr><td>at +60m</td><td></td></tr> <tr><td>at +90m</td><td></td></tr> <tr><td>at +120m : etc</td><td></td></tr> <tr><td>Storm water disposal body</td><td></td></tr> <tr><td>HFL</td><td></td></tr> <tr><td>Normal water level</td><td></td></tr> <tr><td>Bed level</td><td></td></tr> <tr><td>Whether drain trained/untrained</td><td></td></tr> <tr><td>Trained length</td><td></td></tr> <tr><td>Untrained length</td><td></td></tr> <tr><td>Any constrictions like culvert</td><td></td></tr> <tr><td>Identify each such culvert</td><td></td></tr> <tr><td>Drain -- Bed surface material & condition</td><td></td></tr> <tr><td>Manning's 'n' value</td><td></td></tr> <tr><td></td><td></td></tr> <tr><td>Sidewalls material & condition</td><td></td></tr> <tr><td>'n' value</td><td></td></tr> <tr><td>Combined 'n' value at every multiple 0.1 m depth of flow</td><td></td></tr> </table>	at + 30m		at +60m		at +90m		at +120m : etc		Storm water disposal body		HFL		Normal water level		Bed level		Whether drain trained/untrained		Trained length		Untrained length		Any constrictions like culvert		Identify each such culvert		Drain -- Bed surface material & condition		Manning's 'n' value				Sidewalls material & condition		'n' value		Combined 'n' value at every multiple 0.1 m depth of flow		
at + 30m																																								
at +60m																																								
at +90m																																								
at +120m : etc																																								
Storm water disposal body																																								
HFL																																								
Normal water level																																								
Bed level																																								
Whether drain trained/untrained																																								
Trained length																																								
Untrained length																																								
Any constrictions like culvert																																								
Identify each such culvert																																								
Drain -- Bed surface material & condition																																								
Manning's 'n' value																																								
Sidewalls material & condition																																								
'n' value																																								
Combined 'n' value at every multiple 0.1 m depth of flow																																								
2.13	<p>Coefficient of Roughness for use in Manning's Formula:</p> <p>(in the DPR column, fill values only for the material used and mark others as 'not used')</p>																																							

S. No	Description				Write 'Yes' or 'No' etc. in the column below	
					If Yes, give Page No./DPR volume reference. If No, reasons thereof	
	Type of Material			'n' as per Manual	'n' as per DPR Design	
1	Salt-glazed Stoneware Pipes	a) Good		0.012		
		b) Fair		0.015		
2	Cement Concrete Pipes(with collar joints)	a) Good		0.013		
		b) Fair		0.015		
3	Spun Concrete Pipes (RCC & PSC) with socket & spigot joints (Design value)			0.011		
4	Masonry	a) Neat Cement Plaster		0.018		
		b) Sand & cement plaster		0.015		
		c) Concrete –steel troweled		0.014		
		d) Concrete – Wood troweled		0.015		
		e) Brick in good condition		0.015		
		f) Brick in rough condition		0.017		
		g) Masonry in bad condition		0.020		
5	Stone Work	a) Smooth dressed Ashlar		0.015		
		b) Rubble set in cement		0.017		
		c) Fine, well-packed gravel		0.020		
6	Earth	a) Regular surface in good condition		0.020		
		b) In ordinary condition		0.025		
		c) With stones and weeds		0.030		
		d) In poor condition		0.035		
		e) Partially obstructed with debris or weeds		0.050		

S. No	Description					Write 'Yes' or 'No' etc. in the column below		
						If Yes, give Page No./DPR volume reference. If No, reasons thereof		
	7	Steel	a) Welded	0.013				
			b) Riveted	0.017				
			c) Slightly tuberculated	0.020				
			d) With spun cement mortar lining	0.011				
	8	Cast Iron	a)Unlined	0.013				
			b)With spun cement mortar lining	0.013				
	9	Asbestos Cement		0.011				
	10	Plastic (smooth)		0.011				
	2.14	Whether the authenticated data of autographic rainfall data for the project area for the last 25 to 30 years or more has been obtained from India Meteorological Department and furnished in the DPR? Whether it has been analysed as described in the CPHEEO Storm Water Drainage Manual and the intensity – duration – frequency (IDF) curve for the project area has been drawn? Give details as per the model below:						
	2.15	Rainfall Data & Analysis (use additional sheets if required):						
	No. of years of autographic rainfall Data from IMD(India Meteorological Department)							
	Whether autographic rainfall data analysed and arranged in duration (minutes) and intensity (mm/hr)							
	Duration-wise compilation of rainfall data (refer Manual)							
	Frequency of storms of different duration							

S. No	Description		Write 'Yes' or 'No' etc. in the column below	
			If Yes, give Page No./DPR volume reference. If No, reasons thereof	
	Total no. of rainfall events of 5 min duration (arranged in ascending intensity)			
	Similarly, events of 10 min duration (arranged in ascending intensity)			
	Similarly, events of 15 min duration			
	20 min duration			
	30 min duration			
	40 min duration			
	60 min duration			
	90 min duration			
	120 min duration			
	150 min duration			
	180 min duration, etc			
	Storm Frequency (or Storm Return Period / Flooding design interval):			
Land Use Classification		Storm frequency as per Manual	As per DPR Design	
a) Residential Areas				
i) Peripheral areas		Twice a year		
ii) Central and comparatively high priced areas		Once a year		
b) Commercial and High-priced areas		Once in 2 years		

S. No	Description								Write 'Yes' or 'No' etc. in the column below	
									If Yes, give Page No./DPR volume reference. If No, reasons thereof	
	Analysis of Frequency of Storms (Rainfall Events)(Historical data)									
	Duration of rainfall, in minutes	No. of storms of particular duration of the intensity(mm /hr) given below or more during the data period								
		20	30	35	40	45	50	60	Etc.	
	5									
	10									
	15									
	20									
	30									
	40									
	60									
	90									
	120									
	150									
	180									
	etc									
	Time (Duration) – Intensity values of storms from the step curve(for use in log-log graph)									
	<i>i</i> '(mm/hr)				<i>t</i> (min)					
	20									
	30									

S. No	Description		Write 'Yes' or 'No' etc. in the column below												
			If Yes, give Page No./DPR volume reference. If No, reasons thereof												
		<table border="1"> <tr><td>35</td><td></td></tr> <tr><td>40</td><td></td></tr> <tr><td>45</td><td></td></tr> <tr><td>50</td><td></td></tr> <tr><td>55</td><td></td></tr> <tr><td>60</td><td></td></tr> </table>	35		40		45		50		55		60		
35															
40															
45															
50															
55															
60															
	<p>Derived values of <i>i</i> & <i>t</i> from log-log graph of above table. $i = a/t^n$ Derived value of 'a' = Derived value of 'n' = Storm Intensity Equation $i = a/t^n$ $i = \dots\dots\dots$</p> <p>Time of concentration:</p> $t_o = \frac{0.994 (1.1-C)L^{0.5}}{S^{0.333}}$ <p>Where, t_o = Time of surface flow (in minutes) C = Rational Method runoff coefficient L = Length of surface flow (m) S = Surface Slope, in percentage (%)</p>														

S. No	Description	Write 'Yes' or 'No' etc. in the column below If Yes, give Page No./DPR volume reference. If No, reasons thereof
	<p>Note: If slope (S) is expressed as a ratio, then the formula to be applied is</p> $t_o = \frac{0.218 (1.1 - C)L^{0.5}}{S^{0.333}}$ <p>Whether the IDF (Intensity-Duration-Frequency) curve has been drawn –Yes/No</p>	
2.16	Whether Best Management Practices like Rainwater Harvesting and Innovative Practices are given in DPR?	
2.17	<p>Whether the provision of the land/land acquisition for the SWD pumping station/mains, SWD network, if any, has been made as per 30 years requirement and future expansion in the DPR</p> <p>(a) Total requirement of land for: SWD Pumping Station : Hectares Laying of SWD pumping mains : Hectares SWD network : Hectares Total : Hectares Whether land in possession with Implementing Agency : Hectares</p> <p>(b) Whether Govt. land is yet to be transferred to the Implementing Agency and specify time required for transfer :Hectare, months</p> <p>(c) Whether private land under acquisition and time required for acquisition:Hectare, months</p> <p>(d) Status of action initiated for transfer of Govt. land and acquisition of private land (please specify) :</p>	

S. No	Description	Write 'Yes' or 'No' etc. in the column below
		If Yes, give Page No./DPR volume reference. If No, reasons thereof
2.18	Whether all components of storm water drainage system such as inlets, catch pits, SWD pipelines/drains, points of confluence and natural drains with outfalls have been designed as per the CPHEEO Manual and detailed drawings have been provided in the DPR	
2.19	Give Design values and infrastructure proposals for each component(use additional sheets)	
2.20	Whether the Computer-Aided Design of SWD system has been furnished in DPR. Please enclose design input files (sheets) and output files (sheets) separately	
2.21	Whether the rising main of SWD system, if any, has been designed for catchment flows with respect to time of concentration and checked for a minimum velocity of 0.6 m/s and maximum velocity of 3 m/s?	
2.22	Whether node spacing while designing have been adopted as per CPHEEO Manual?	
2.23	Whether the designs of SWD pipes/drains have been checked for a minimum self-cleaning velocity of 0.6 m/s by providing proper slope	
2.24	Whether surge/water hammer analysis for rising main has been calculated and furnished in the DPR	
2.25	Whether the provision for rising main units, wherever needed, such as thrust blocks, anchor blocks, expansion joints, scour/drain valves, air/vacuum releases valves and surge protection devices have been provided in the DPR	
2.26	Whether drawings to scale of L-sections of SWD drains/pipelines with all details such as ground level, crown level, invert level, depths of excavation, bedding details etc., have been furnished in DPR	
2.27	Whether the configuration of the pumps proposed in SWD/drainage pumping stations is in conformity with the general guidelines of CPHEEO Manual for conveying maximum design flood, need for standby and operational capability above high flood level (HFL)	

S. No	Description	Write 'Yes' or 'No' etc. in the column below
		If Yes, give Page No./DPR volume reference. If No, reasons thereof
2.28	Whether the pipe material has been selected considering the topography, efficiency in service, ease of laying and economy in DPR	
2.29	Whether bedding conditions for different reaches of the proposed SWD pipelines/drains have been designed in the DPR as per CPHEEO Manual with reference to soil characteristics	
	Class A Bedding: Length proposedKm in soils of	
	Classification	
	Class B Bedding: Length proposedKm in soils of	
	Classification	
	Class C Bedding: Length proposedKm in soils of	
	Classification	
2.30	Whether a detailed note on performance of existing SWD/drainage network and pumping station, if any has been furnished in the DPR	
2.31	Whether SWD system has provision for flood diversion to water bodies and for enabling ground water recharge	
2.32	Whether the ULBs certificate to the effect that no municipal sewage shall be discharged into the SWD system has been provided in the DPR	
2.33	Whether Bill of Qualities (BOQ) and cost estimates of individual components of drainage system prepared as per latest SOR and copy of latest Schedule of Rates (SOR) and Pro-forma invoices have been annexed with DPR. (a) Schedule of Rates adopted (please specify the year): -----year (b) In case the SOR adopted is old, please specify the cost index for escalation approved by State Govt. (c) Any price escalation proposed in cost estimates as notified by State Govt. (d) Whether analysis of rate has been worked out for all the items and appended with DPR	

S. No	Description	Write 'Yes' or 'No' etc. in the column below			
		If Yes, give Page No./DPR volume reference. If No, reasons thereof			
	(e) Whether Bill of Quantities of individual component has been furnished in DPR (f) Whether lump sum(LS) provision for any item has been proposed, please specify				
2.34	Whether detailed drawing, estimation & detailed BOQ for ancillary works such as boundary wall/fencing, approach & internal road, external electrification, buildings, site development/landscaping etc. has been provided in the DPR for any SWD Pumping Station				
	Give the General Abstract Cost Estimate and Component-wise or package-wise Abstract Cost Estimate: (use additional sheets if required)				
2.35	Whether provision for DG set has been made in the DPR to tide over interruptions in power supply, if any				
2.36	If yes, whether the calculations to arrive at the capacity of the same has been mentioned in the technical reports				
2.37	Whether provision for road restoration has been made as per CPWD/ State PWD/ Urban Local Body norms				
2.38	Give the List of Tender Packages made for 'notice inviting tender' (Use additional sheets if required) . Furnish the title-wise Tender packages and their value.				
2.40	Calculate service level benchmark as per MoUD. Please furnish SLB.				
	Sl. No.	Indicator	Before implementation of the project	After implementation of the project	Benchmark
	1.	Coverage			100%
	2.	Incidence of waterlogging			0 numbers
2.41	Whether project implementation period of project has been furnished in DPR Specify the implementation period:.....year				

S. No	Description	Write 'Yes' or 'No' etc. in the column below				
		If Yes, give Page No./DPR volume reference. If No, reasons thereof				
2.42	Whether detailed BAR Chart and PERT/CPM network showing implementation schedule has been furnished in DPR					
2.43	Whether Internal rate of return (IRR) / Economic rate of return (ERR) has been furnished in DPR					
2.44	Whether traffic diversion/ control arrangements for public and workers' safety, arising out of construction phase of storm water drainage works have been furnished in the DPR					
2.45	Whether Institutional and financial status of Project Executing Agency (PEA) has been reported in DPR					
2.46	Whether Operation & Maintenance cost and revenue generation details (O & M Framework – existing & proposed) has been furnished in DPR (a) Existing tariff / cess / charges (in Rs.): Residential -- Commercial -- Institutions -- Industries -- (b) Proposed tariff/cess/charges (in Rs.) Residential -- Commercial -- Institutions -- Industries --					
	(c) Annual O & M cost (Rs. in lakhs)					
	(i) Existing (last 5 years)	1	2	3	4	5

S. No	Description	Write 'Yes' or 'No' etc. in the column below				
		If Yes, give Page No./DPR volume reference. If No, reasons thereof				
	(ii) Proposed					
2.47	(d) Annual Revenue (Rs. in lakhs)					
	(i) Existing (last 5 years)	1	2	3	4	5
	(ii) Proposed					
2.48	Whether Environmental and social problems (if applicable) has been furnished in DPR					
2.49	Whether provision has been made @ 0.5% of the project cost in the DPR for capacity building of ULBs for further O&M of the scheme after taking over the scheme from implementing agency. Please furnish the action plan for conducting capacity building programme. The action plan must specify specific actions such as the number of officials to be deployed in the project post-commissioning, their designations, qualifications and training proposed to be given.					
2.50	Whether Rehabilitation and Resettlement plan (if applicable) has been given in DPR					
2.51	Whether all the hard copies of the DPR furnished along with soft copies/					
2.52	Period of completion of the project					

Signed:
Name:
Designation:

Signed:
Name:
Designation:

APPENDIX A 4.1
EXAMPLE ON PARTIAL AREA EFFECT

Case 1

A sub-catchment has following properties:

	Catchment A	Catchment B
Run off Coefficient C	0.6	0.9
Time of concentration	30 min	5 min
Area	0.6 km ²	0.2 km ²

A storm event of 10 years Return Period having 90 Min duration rainfall results following intensities:

- 5 min – 200 mm/hr
- 30 min – 60 mm/hr

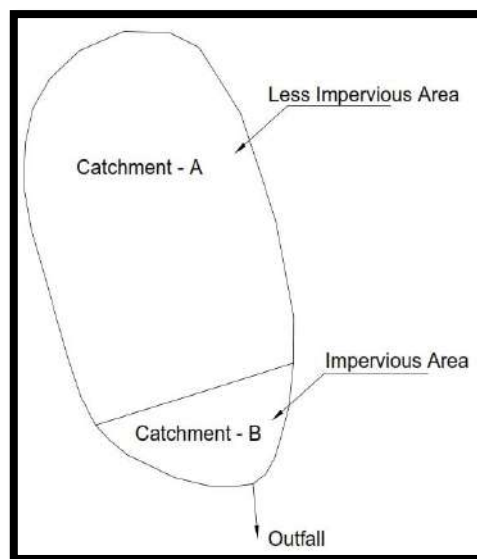

Find out peak runoff from the catchment for by rational method.

Solution (a)

$$Q = C_{avg} I A$$

$$\text{Weighted average C} = \frac{C_1 A_1 + C_2 A_2 + C_3 A_3 + \dots}{A_1 + A_2 + A_3 + \dots}$$

$$= \frac{0.9 \times 0.2 + 0.6 \times 0.6}{0.2 + 0.6} = 0.675$$

$$I = 60 \text{ mm/hr}$$

$$A+B = (0.2 + 0.6) \text{ km}^2 = 0.8 \text{ km}^2$$

$$K = 1/3.6$$

$$Q = (0.675 \cdot 60 \cdot 0.8) / 3.6 = 9.0 \text{ m}^3 / \text{sec}$$

Solution (b)

$$Q = C I A$$

$$C = 0.9$$

$$I = 200 \text{ mm/hr}$$

$$A = 0.2 \text{ km}^2$$

$$K = 1/3.6$$

$$Q = (0.9 \cdot 200 \cdot 0.2) / 3.6 = 10.0 \text{ m}^3 / \text{sec}$$

Maximum of the above two values shall be taken. Therefore $Q = 10.0 \text{ m}^3 / \text{sec}$

Case II

A sub-catchment has following properties:

	Catchment A	Catchment B (contributory)
Run off Coefficient C	0.6	0.9
Time of concentration	60 min	10 min
Area	1.0 km ²	0.3 km ²

A storm event of 10 years Return Period having 90 Min duration rainfall results following intensities:

- 10 min – 130 mm/hr
- 60 min – 40 mm/hr

Find out peak runoff from the catchment for by rational method.

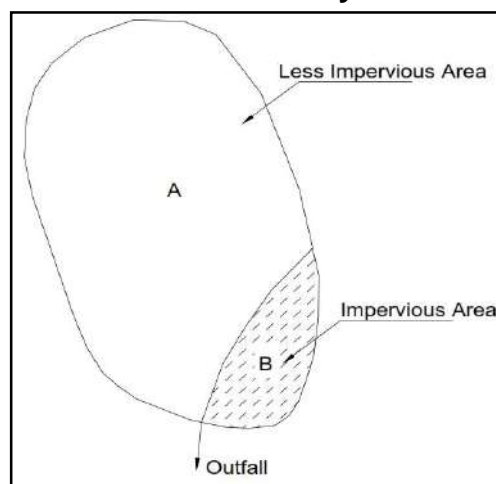

Solution (a)**Flow for Catchment A for time of concentration of 60 min**

$$Q = C I A$$

$$K = 1/3.6$$

$$Q_1 = (0.6 \times 40 \times 1)/3.6 = 6.67 \text{ m}^3/\text{sec}$$

Flow for Catchment B for time of concentration of 60 min

$$Q_2 = (0.9 \times 40 \times 0.3)/3.6 = 3 \text{ m}^3/\text{sec}$$

$$\text{Total Flow at Outlet} = Q_1 + Q_2 = 6.67 + 3 = 9.67 \text{ m}^3/\text{sec}$$

Solution (b)**Flow for Catchment B for Time of concentration 10 min**

$$Q = C I A$$

$$K = 1/3.6$$

$$Q_1 = (0.9 \times 130 \times 0.3)/3.6 = 9.75 \text{ m}^3/\text{sec}$$

APPENDIX A 4.2 EXAMPLE ON TIME-AREA-METHOD

PROBLEM:

Construct the runoff hydrograph for 10 hectare catchment where total time of concentration is 15 minutes. The time distribution of rainfall and corresponding losses are given below. Use time area method to develop the hydrograph.

Time (minutes)	Rainfall depth (mm)	Infiltration and other losses (mm)	Effective rainfall(mm)
0	0	0	0
3	11.4	1.5	9.9
6	15.9	0	15.9
9	9.1	0	9.1
12	6.8	0	6.8
15	2.3	0	2.3

SOLUTION:

Draw isochrones approximately sub dividing the catchment for 3, 6, 9, 12, and 15 minutes travel time period considering total time of concentration. Measure areas between adjacent isochrones and tabulate cumulative time areas as follows.

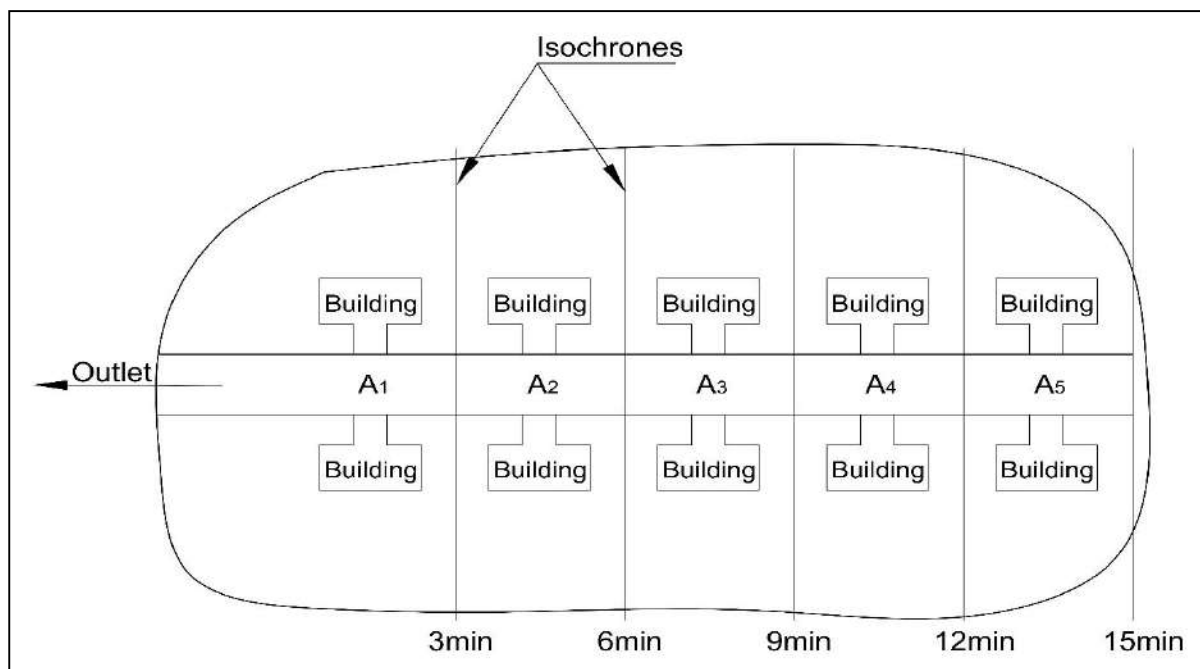

Time (Minutes)	Cumulative area Area in m ²
0	0
3	27000
6	50000
9	69000
12	85000
15	100000

Runoff generated from each catchment due to incremental effective rainfall amount is calculated reaching the outfall.

Travel time of each zone is 3 minutes. Rainfall occurs over the entire catchment in three minutes interval as shown with losses as given in the above table taken as I_1, I_2, I_3, I_4, I_5 .

Now in first 3 minutes interval, I_1 rainfall has fallen over the entire catchment and therefore after 3 minutes interval the output discharge at outlet is contributed by sub-catchment A_1 from rainfall I_1 . And hence, discharge $q_1 = A_1 * I_1$

Similarly, I_2 rainfall has fallen in second 3-minute interval, the discharge $A_2 * I_1$ and $A_1 * I_2$ reach simultaneously at the outlet, $q_2 = A_2 * I_1 + A_1 * I_2$

Similarly by lagging and adding $q_3 = A_3 * I_1 + A_2 * I_2 + A_1 * I_3$
 $q_4 = A_4 * I_1 + A_3 * I_2 + A_2 * I_3 + A_1 * I_4$
 $q_5 = A_5 * I_1 + A_4 * I_2 + A_3 * I_3 + A_2 * I_4 + A_1 * I_5$

After lapse of 15 minutes the rain stops and rainfall generated by I_1 is entirely drained out at the outlet.

Rest of the incremental rainfalls falling over the sub-catchment subsequently reach the outlet point as given by lagging and adding sub-catchments flows hereunder.

$$q_6 = A_5 * I_2 + A_4 * I_3 + A_3 * I_4 + A_2 * I_5$$

$$q_7 = A_5 * I_3 + A_4 * I_4 + A_3 * I_5$$

$$q_8 = A_5 * I_4 + A_4 * I_5$$

$$q_9 = A_5 * I_5$$

$$q_{10} = 0$$

For computing if q in m³/s, A , area between isochrones in m², incremental rainfall, I , in mm and time interval, t , in minutes then,

$$q = 0.001 * I * A / 60 * t$$

The total discharges after each successive interval are shown in the following table:

Time in minutes	Effective Rainfall in mm	Area of sub-catchment in m ²	Runoff generated by effective rainfall in m ³ /sec					Hydrograph In m ³ /s
			Effective Rainfall (mm)	Effective Rainfall (mm)	Effective Rainfall (mm)	Effective Rainfall (mm)	Effective Rainfall (mm)	
0	0	0	0	0	0	0	0	0
3	9.9	27000	1.48	0				1.48
6	15.9	23000	1.26	2.39	0			3.65
9	9.1	19000	1.04	2.03	1.37	0		4.44
12	6.8	16000	0.88	1.68	1.16	1.02	0	4.75
15	2.3	15000	0.82	1.42	0.96	0.87	0.34	4.41
18	0	0	0	1.33	0.81	0.72	0.29	3.15
21	0	0	0	0	0.76	0.61	0.24	1.61
24	0	0	0	0	0	0.57	0.20	0.77
27	0	0	0	0	0	0	0.19	0.19
30	0	0	0	0	0	0	0	0

Hydrograph is drawn as shown below.

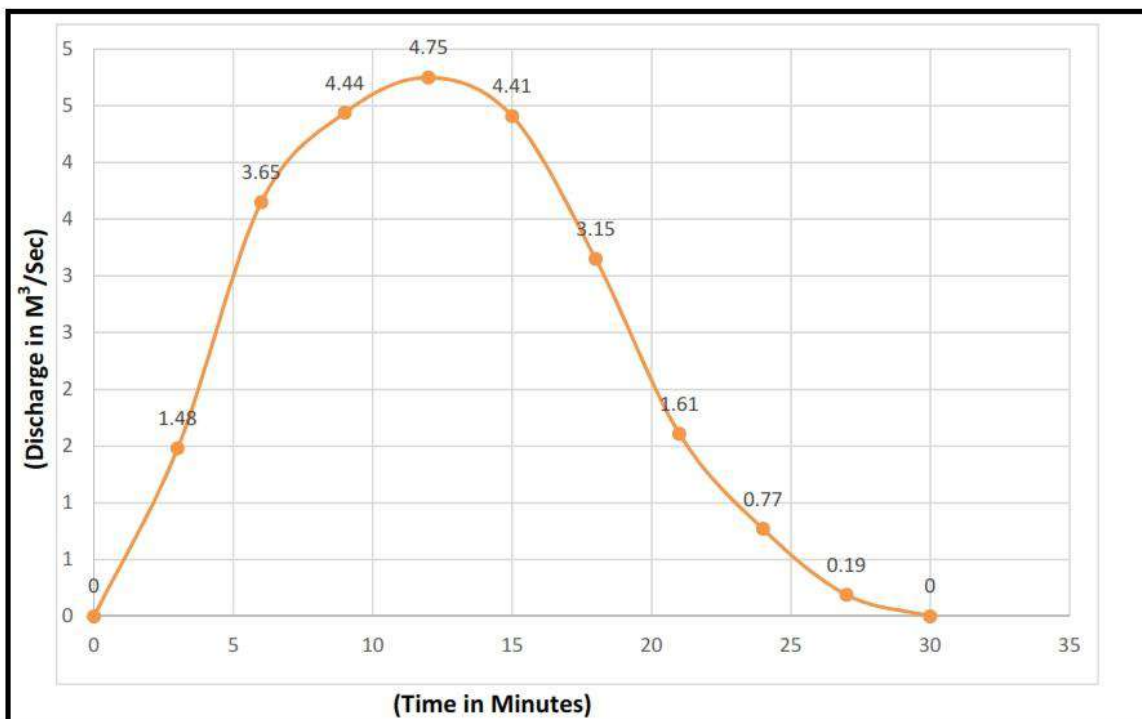

APPENDIX A 4.3 EXAMPLE ON UNIT HYDROGRAPH METHOD

PROBLEM:

A park garden in Nagloi area of Delhi city covering an area of 10 hectare drains at a single outlet as shown in the figure given below. It is proposed to drain out the storm water from the park from its outlet point to the nearest big Nallah by laying RCC pipe approximately 500.0 m in length. Design the size of pipe and determine the peak flow at the outlet of the catchment.

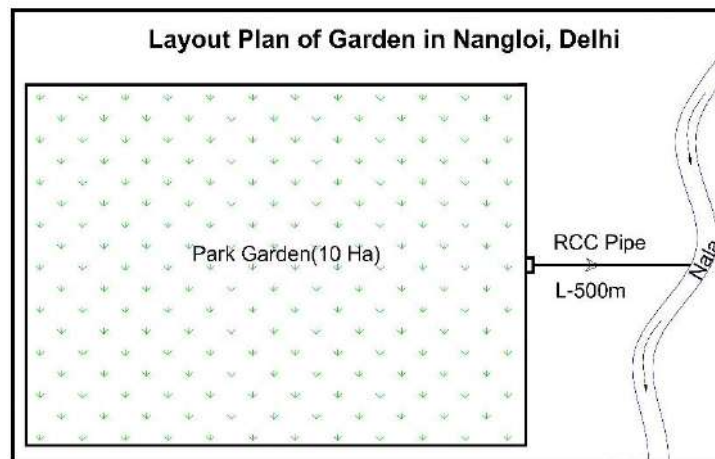
**SOLUTION:**

Given, the ordinates of unit hydrograph of the catchment and design hyetograph of the effective rainfall.

Unit hydrograph ordinates											
Time (min)	0	3	6	9	12	15	18	21	24	27	30
Discharge in m³/sec	0	0.336	0.829	1.009	1.079	1.002	0.715	0.366	0.175	0.043	0

Design Hyetograph of effective rainfall	
Time in minutes	Rainfall in cm
0	0
3	0.99
6	1.59
9	0.91
12	0.68
15	0.23

Computation of DRH for the garden catchment							
Time (Min)	Ordinates of UH in m ³ /s	DRH for 0.99 cm ERH in m ³ /s	DRH for 1.59 cm ERH in m ³ /s	DRH for 0.91cm ERH in m ³ /s	DRH for 0.68cm ERH in m ³ /s	DRH for 0.23 cm ERH in m ³ /s	DRH of the catchment (Col. 3+4+5+6+7) in m ³ /s
1	2	3	4	5	6	7	8
0	0	0	0	0	0	0	0
3	0.336	0.3326	0	0	0	0	0.3326
6	0.829	0.8207	0.5342	0	0	0	1.3549
9	1.009	0.9989	1.3181	0.3057	0	0	2.622
12	1.079	1.0682	1.6043	0.7543	0.2284	0	3.655
15	1.002	0.9919	1.7156	0.9181	0.5637	0.6772	4.266
18	0.715	0.7078	1.5931	0.9818	0.6861	0.1906	4.159
21	0.366	0.3623	1.1368	0.9118	0.7337	0.232	3.376
24	0.175	0.1732	0.5819	0.6506	0.6813	0.2481	2.335
27	0.043	0.0425	0.2782	0.333	0.4862	0.2304	1.37
30	0	0	0.0683	0.1592	0.2488	0.1644	0.64
33	0	0	0	0.0391	0.119	0.0841	0.242
36	0	0	0	0	0.0292	0.0402	0.069
39	0	0	0	0	0	0.0098	0.009
42	0	0	0	0	0	0	0

Basic principles of theory and application of unit hydrograph to generate DRH may be referred in chapter 4. In accordance with theory of linear response that is if the rainfall excess in a duration 'D' hour is 'r' times the unit depth (1 cm), the ordinate of the resulting hydrograph will be 'r' times the corresponding ordinate of 'D' hour unit hydrograph. The table shows the ERH depth of subsequent interval multiplied by the unit hydrograph ordinates in column 2 by subsequently lagging as per time interval which is evident from the above table of computation. DRH of the park – garden is drawn and given below:

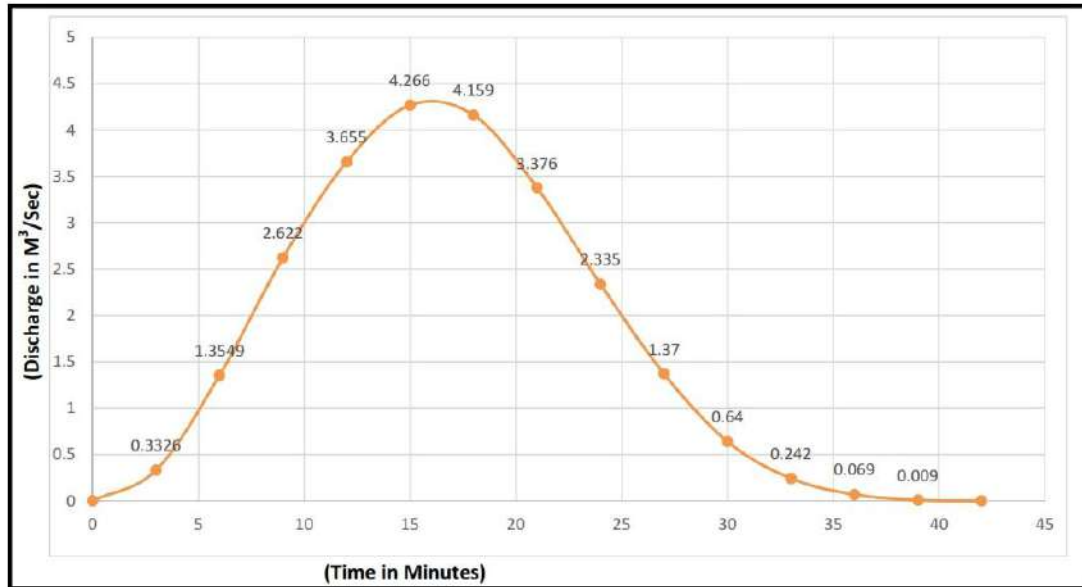

Peak flow at the outlet of the garden (from above hydrograph) = 4.266m³/sec

Using Manning formula and taking a value of 'n' 0.013 it is computed that pipe of diameter 2000 mm having a slope of 1 in 1220 shall have following hydraulic characteristics:

$$Q \text{ (full)} = 4.35 \text{ m}^3/\text{sec}$$

$$V \text{ (full)} = 1.38 \text{ m/sec}$$

$$Q \text{ (design)} = 4.266 \text{ m}^3/\text{sec}$$

$$V \text{ (design)} = 1.58 \text{ m/sec}$$

Therefore the above design of RCC pipe is adopted for conveying the peak flow of storm water to the receiving water of the big Nallah.

Computation:

$$Q_f = \frac{A^{5/3} * S^{1/2}}{n * p^{2/3}}$$

Where, Q_f : Full section flow in the conduit

A : Cross-section of the conduit

S : Bed slope

Substituting the values of pipe and slope parameters as given above

$$Q_f = \frac{3.14^{1.66} * \left(\frac{1}{1220}\right)^{1/2}}{0.013 * 6.26^{2/3}}$$

$$= 4.354 \text{ m}^3/\text{sec}$$

$$V_f = 4.354/3.14 = 1.38 \text{ m/sec}$$

From Table 5.5 of Chapter 5

$$Q(\text{design})/Q_f = 0.97, \text{ then, } v(\text{design})/V_f = 1.14, \text{ } d(\text{design})/D(\text{full}) = 0.8$$

Hence $v(\text{design}) = 1.38 * 1.14 = 1.58 \text{ m/sec}$ approximately

$$\text{Depth of flow} = 0.8 * 2 = 1.60 \text{ m}$$

APPENDIX A 5.1
EXAMPLE ON CRITICAL DEPTH

PROBLEM:

Calculate the critical depth and the corresponding specific energy for a discharge of $5.0 \text{ m}^3/\text{sec}$ in the following channels:

- a) Rectangular Channel $B = 2.0 \text{ m}$
- b) Triangular Channel $m = 0.5$
- c) Trapezoidal Channel $B = 2.0 \text{ m}; m = 1.5$
- d) Circular Channel $D = 2.0 \text{ m}$

Solution:**Rectangular Channel:**

$$q = \frac{Q}{B} = \frac{5.0}{2.0} = 2.5 \text{ m}^3/\text{s/m}$$

$$y_c = \sqrt[3]{\frac{q^2}{2g}} = \sqrt[3]{\frac{2.5^2}{2 \times 9.81}} = 0.860 \text{ m}$$

$$\frac{E_c}{Y_c} = 1.5 ; E_c = 1.290 \text{ m}$$

For Triangular Channel,

$$y_c = \sqrt[5]{\frac{2Q^2}{gm^2}} = \sqrt[5]{\frac{2 \times 5^2}{9.81 \times 0.5^2}} = 1.828 \text{ m}$$

$$\frac{E_c}{Y_c} = 1.25 ; E_c = 2.284 \text{ m}$$

For Trapezoidal Channel,

$$\Psi = \frac{Qm^{3/2}}{\sqrt{g}B^{5/2}} = \frac{0.5 \times 1.5^{3/2}}{\sqrt{9.81} 2^{5/2}} = 0.51843$$

Using Appendix 5.4, corresponding values:

$$\xi = \frac{my_c}{B} = 0.536$$

$$Y_c = 0.715 \text{ m}$$

$$A_c = (2.0 + 1.5 \times 0.715) \times 0.715 = 2.197 \text{ m}^2$$

$$V_c = \frac{5}{2.197} = 2.276 \text{ m/sec}$$

$$E_c = y_c + \frac{v_c^2}{2g} = 0.715 + 0.264 = 0.979 \text{ m}$$

Circular Section

$$Z = \frac{Q}{\sqrt{g}} = \frac{5}{\sqrt{9.81}} = 1.5964$$

$$\frac{Z}{d_0^{2.5}} = \frac{1.5964}{2^{2.5}} = 0.2822$$

Computing value from Appendix 5.4: $\frac{y}{d_0} = 0.537$

$$y_c = 1.074 \text{ m}$$

**APPENDIX A 5.2
DETAILS OF STANDARD SIZED STEPPED CHANNELS**

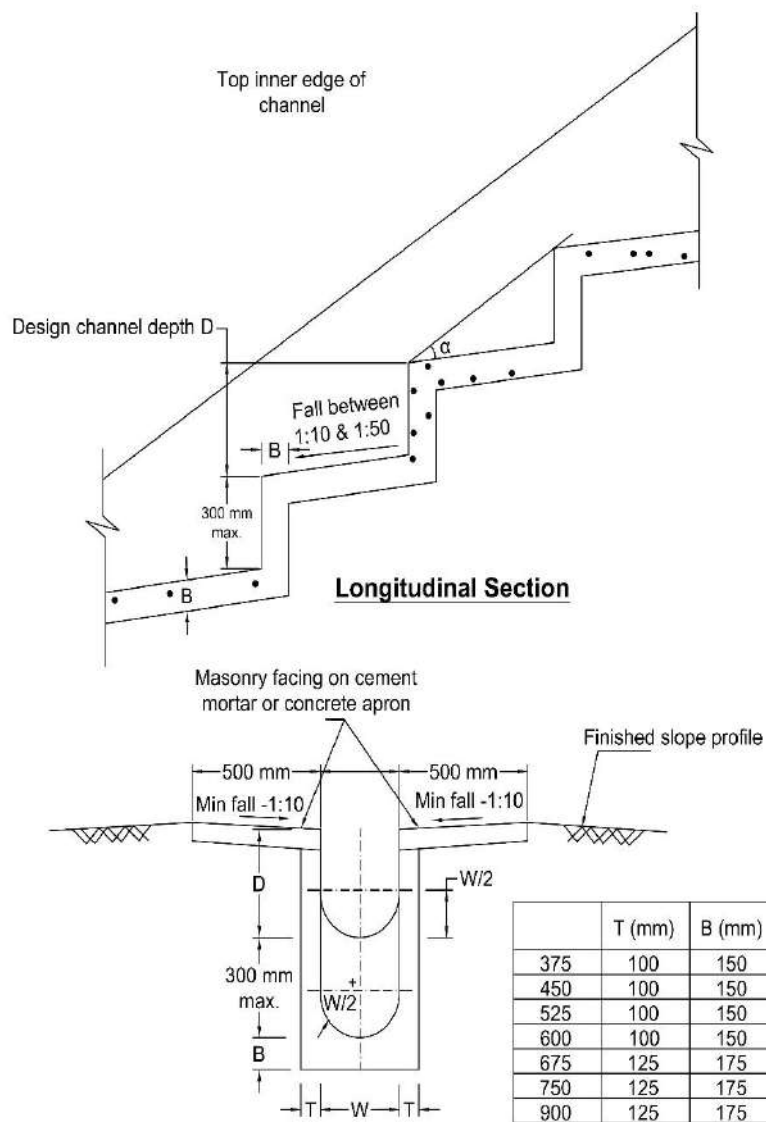

DESIGN CHART FOR STANDARD SIZED STEPPED CHANNELS

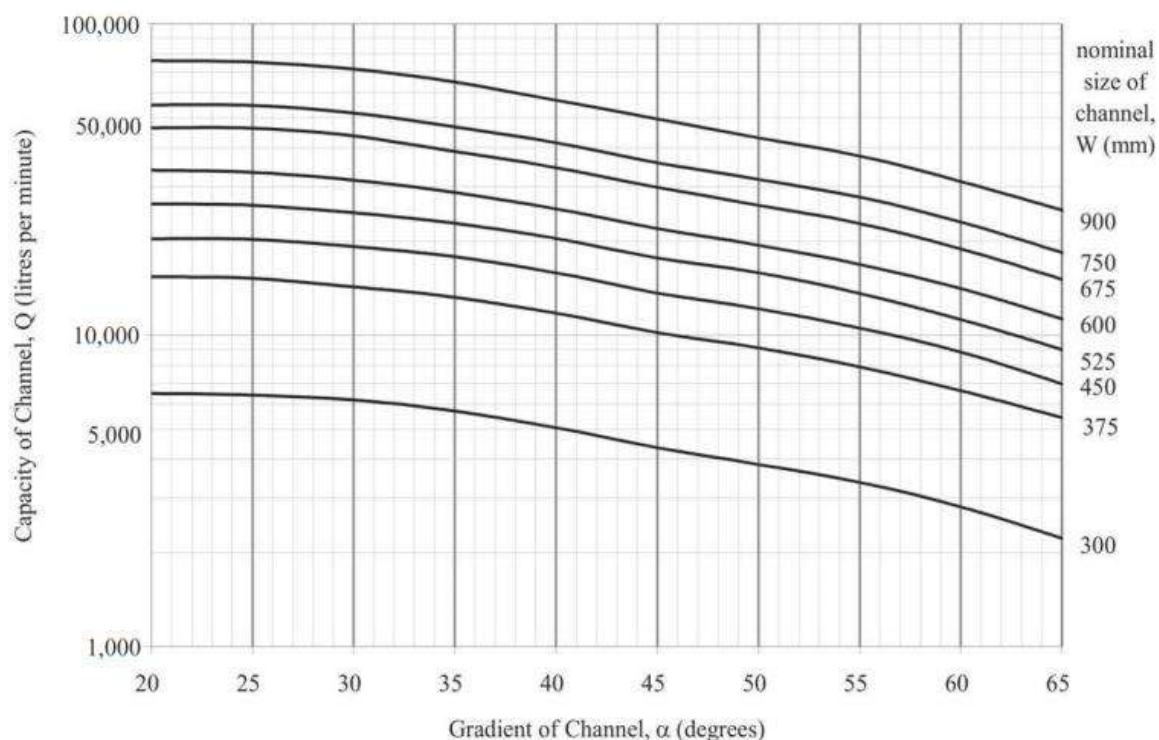

Recommended Minimum Length of Standard Sized Stepped Channels (metres)

Nominal size of channel, W(mm)	Channel gradient, α (degrees)									
	20	25	30	35	40	45	50	55	60	65
300	3.3	3.2	3.1	3.0	3	3.0	3.0	3.0	3	3.0
375	5.1	5	4.8	4.7	4.5	4.3	4.3	4.3	4.3	4.3
450	5.5	5.4	5.2	5.1	4.8	4.6	4.6	4.6	4.6	4.6
525	6.0	5.8	5.7	5.4	5.2	5.0	5.0	5.0	5	5.0
600	6.4	6.3	6.1	5.8	5.6	5.3	5.3	5.3	5.3	5.3
675	7.3	7.2	6.9	6.6	6.3	6.1	6.0	6.0	6	6.0
750	7.8	7.6	7.3	7.0	6.7	6.4	6.4	6.3	6.3	6.3
900	8.6	8.4	8.1	7.8	7.4	7.0	7.0	7.0	7	7.0

APPENDIX A 5.3
GEOMETRIC ELEMENTS FOR CIRCULAR CHANNEL SECTIONS

d_o =diameter	R =hydraulic radius
y =depth of flow	T =top width
A =water area	D =hydraulic depth
P =wetter perimeter	$Z=A\sqrt{D}$ =section factor for critical-flow computation

y/d_o	A/d_o^2	P/d_o	R/d_o	T/d_o	D/d_o	$Z/d_o^{2.5}$	$AR^{2/3}/d_o^{2.5}$
0.01	0.0013	0.2003	0.0066	0.1990	0.0066	0.0001	0.0000
0.02	0.0037	0.2838	0.0132	0.2800	0.0134	0.0004	0.0002
0.03	0.0069	0.3482	0.0197	0.3412	0.0202	0.0010	0.0005
0.04	0.0105	0.4027	0.0262	0.3919	0.0268	0.0017	0.0009
0.05	0.0147	0.4510	0.0326	0.4359	0.0336	0.0027	0.0015
0.06	0.0192	0.4949	0.0389	0.4750	0.0406	0.0039	0.0022
0.07	0.0242	0.5355	0.0451	0.5103	0.0474	0.0053	0.0031
0.08	0.0294	0.5735	0.0513	0.5426	0.0542	0.0069	0.0040
0.09	0.0350	0.6094	0.0574	0.5724	0.0612	0.0087	0.0052
0.10	0.0409	0.6435	0.0635	0.6000	0.0682	0.0107	0.0065
0.11	0.0470	0.6761	0.0695	0.6258	0.0752	0.0129	0.0079
0.12	0.0534	0.7075	0.0754	0.6499	0.0822	0.0153	0.0095
0.13	0.0600	0.7377	0.0813	0.6728	0.0892	0.0179	0.0113
0.14	0.0668	0.7670	0.0871	0.6940	0.0964	0.0217	0.0131
0.15	0.0739	0.7954	0.0929	0.7141	0.1034	0.0238	0.0152
0.16	0.0811	0.8230	0.0986	0.7332	0.1106	0.0270	0.0173
0.17	0.0885	0.8500	0.1042	0.7513	0.1178	0.0304	0.0196
0.18	0.0961	0.8763	0.1042	0.7684	0.1252	0.0339	0.0220

y/d_o	A/d_o^2	P/d_o	R/d_o	T/d_o	D/d_o	$Z/d_o^{2.5}$	$AR^{2/3}/d_o^{2.5}$
0.19	0.1039	0.9020	0.1152	0.7846	0.1324	0.0378	0.0247
0.20	0.1118	0.9273	0.1206	0.8000	0.1398	0.0418	0.0273
0.21	0.1190	0.9521	0.1259	0.8146	0.1472	0.0460	0.0301
0.22	0.1281	0.9764	0.1312	0.8285	0.1546	0.0503	0.0333
0.23	0.1365	1.0003	0.1364	0.8417	0.1662	0.0549	0.0359
0.24	0.1449	1.0239	0.1416	0.8542	0.1696	0.0597	0.0394
0.25	0.1535	1.0472	0.1466	0.8660	0.1774	0.0646	0.0427
0.26	0.1623	1.0701	0.1516	0.8773	0.1850	0.0697	0.0464
0.27	0.1711	1.0928	0.1566	0.8879	0.1926	0.0751	0.0497
0.28	0.1800	1.1152	0.1614	0.8980	0.2004	0.0805	0.0536
0.29	0.1890	1.1373	0.1662	0.9075	0.2084	0.0862	0.0571
0.30	0.1982	1.1593	0.1709	0.9165	0.2162	0.0921	0.0610
0.31	0.2074	1.1810	0.1755	0.9250	0.2242	0.0981	0.0650
0.32	0.2167	1.2025	0.1801	0.9330	0.2322	0.1044	0.0690
0.33	0.2260	1.2239	0.1848	0.9404	0.2404	0.1107	0.0736
0.34	0.2355	1.2451	0.1891	0.9474	0.2486	0.1172	0.0776
0.35	0.2450	1.2661	0.1935	0.9539	0.2568	0.1241	0.0820
0.36	0.2546	1.2870	0.1978	0.9600	0.2652	0.1310	0.0864
0.37	0.2642	1.3078	0.2020	0.9656	0.2736	0.1381	0.0909
0.38	0.2739	1.3284	0.2061	0.9708	0.2822	0.1453	0.0955
0.39	0.2836	1.3490	0.2102	0.9755	0.2908	0.1528	0.1020
0.40	0.2934	1.3694	0.2142	0.9798	0.2994	0.1603	0.1050
0.41	0.3032	1.3898	0.2181	0.9837	0.3082	0.1682	0.1100
0.42	0.3132	1.4101	0.2220	0.9871	0.3172	0.1761	0.1147
0.43	0.3229	1.4303	0.2257	0.9902	0.3262	0.1844	0.1196

y/d_o	A/d_o^2	P/d_o	R/d_o	T/d_o	D/d_o	$Z/d_o^{2.5}$	$AR^{2/3}/d_o^{2.5}$
0.44	0.3328	1.4505	0.2294	0.9928	0.3352	0.1927	0.1245
0.45	0.3428	1.4706	0.2331	0.9950	0.3446	0.2011	0.1298
0.46	0.3527	1.4907	0.2366	0.9968	0.3538	0.2098	0.1348
0.47	0.3627	1.5108	0.2400	0.9982	0.3634	0.2186	0.1401
0.48	0.3727	1.5308	0.2434	0.9992	0.3730	0.2275	0.1452
0.49	0.3827	1.5508	0.2467	0.9998	0.3828	0.2366	0.1505
0.50	0.3927	1.5708	0.2500	1.0000	0.3928	0.2459	0.1558
0.51	0.4027	1.5908	0.2531	0.9998	0.4028	0.2553	0.1610
0.52	0.4127	1.6108	0.2561	0.9992	0.4130	0.2650	0.1664
0.53	0.4227	1.6308	0.2591	0.9982	0.4234	0.2748	0.1715
0.54	0.4327	1.6509	0.2620	0.9968	0.4340	0.2848	0.1772
0.55	0.4426	1.6710	0.2649	0.9950	0.4448	0.2949	0.1825
0.56	0.4526	1.6911	0.2676	0.9928	0.4558	0.3051	0.1878
0.57	0.4625	1.7113	0.2703	0.9902	0.4670	0.3158	0.1933
0.58	0.4723	1.7315	0.2728	0.9871	0.4786	0.3263	0.1987
0.59	0.4822	1.7518	0.2753	0.9887	0.4902	0.3373	0.2041
0.60	0.4920	1.7722	0.2776	0.9798	0.5022	0.3484	0.2092
0.61	0.5018	1.7926	0.2797	0.9755	0.5144	0.3560	0.2146
0.62	0.5115	1.8132	0.2818	0.9708	0.5270	0.3710	0.2199
0.63	0.5212	1.8338	0.2839	0.9656	0.5398	0.3830	0.2252
0.64	0.5308	1.8546	0.2860	0.9600	0.5530	0.3945	0.230.
0.65	0.5404	1.8755	0.2881	0.9539	0.5666	0.4066	0.2358
0.66	0.5499	1.8965	0.2899	0.9474	0.5804	0.4188	0.2407
0.67	0.5594	1.9177	0.2917	0.9404	0.5948	0.4309	0.2460
0.68	0.5687	1.9391	0.2935	0.9330	0.6096	0.4437	0.2510

y/d_o	A/d_o^2	P/d_o	R/d_o	T/d_o	D/d_o	$Z/d_o^{2.5}$	$AR^{2/3}/d_o^{2.5}$
0.69	0.5780	1.9606	0.2950	0.9250	0.6250	0.4566	0.2560
0.70	0.5872	1.9823	0.2962	0.9165	0.6408	0.4694	0.2608
0.71	0.5964	2.0042	0.2973	0.9075	0.6572	0.4831	0.2653
0.72	0.6054	2.0264	0.2984	0.8980	0.6742	0.4964	0.2702
0.73	0.6143	2.0488	0.2995	0.8879	0.6918	0.5100	0.2751
0.74	0.6231	2.0714	0.3006	0.8773	0.7104	0.5248	0.2794
0.75	0.6318	2.0944	0.3017	0.8660	0.7296	0.5392	0.2840
0.76	0.6404	2.1176	0.3025	0.8542	0.7498	0.5540	0.2888
0.77	0.6489	2.1412	0.3032	0.8417	0.7710	0.5695	0.2930
0.78	0.6573	2.1652	0.3037	0.8285	0.7394	0.5850	0.2969
0.79	0.6655	2.1895	0.3040	0.8146	0.8170	0.6011	0.3008
0.80	0.6736	2.2143	0.3042	0.8000	0.8420	0.6177	0.3045
0.81	0.6815	2.2395	0.3044	0.7846	0.8686	0.6347	0.3082
0.82	0.6893	2.2653	0.3043	0.7684	0.8970	0.6524	0.3118
0.83	0.6969	2.2916	0.3041	0.7513	0.9276	0.6707	0.3151
0.84	0.7043	2.3186	0.3038	0.7332	0.9606	0.6897	0.3182
0.85	0.7115	2.3462	0.3033	0.7141	0.9964	0.7098	0.3212
0.86	0.7186	2.3746	0.3026	0.6940	1.0354	0.7307	0.3240
0.87	0.7254	2.4038	0.3017	0.6726	1.0784	0.7528	0.3264
0.88	0.7320	2.4341	0.3008	0.6499	1.1264	0.7754	0.3286
0.89	0.7380	2.4655	0.2996	0.6258	1.1800	0.8016	0.3307
0.90	0.7445	2.4981	0.2980	0.6000	1.2408	0.8285	0.3324
0.91	0.7504	2.5322	0.2963	0.5724	1.3110	0.8586	0.3336
0.92	0.7560	2.5681	0.2944	0.5426	1.3932	0.8917	0.3345
0.93	0.7612	2.6061	0.2922	0.5103	1.4918	0.9292	0.3350

y/d_o	A/d_o^2	P/d_o	R/d_o	T/d_o	D/d_o	$Z/d_o^{2.5}$	$AR^{2/3}/d_o^{2.5}$
0.94	0.7662	2.6467	0.2896	0.4750	1.6130	0.9725	0.3353
0.95	0.7707	2.6906	0.2864	0.4359	1.7682	1.0242	0.3349
0.96	0.7749	2.7389	0.2830	0.3919	1.9770	1.0888	0.3340
0.97	0.7785	2.7934	0.2787	0.3412	2.2820	1.1752	0.3322
0.98	0.7816	2.8578	0.2735	0.2800	2.7916	1.3050	0.3291
0.99	0.7841	2.9412	0.2665	0.1990	3.9400	1.5554	0.3248
1.00	0.7854	3.1416	0.2500	0.0000	~~	~~	0.3117

APPENDIX A 5.4
VALUES FOR COMPUTATION OF CRITICAL DEPTH IN TRAPEZOIDAL
CHANNEL

ξ	Ψ	ξ	Ψ	ξ	Ψ	ξ	Ψ	ξ	Ψ
0.100	0.0333042	0.330	0.2256807	0.560	0.5607910	0.790	1.0469124	1.020	1.6962526
0.105	0.0359281	0.335	0.2314360	0.565	0.5697107	0.795	1.0592476	1.025	1.7122746
0.110	0.0386272	0.340	0.2372580	0.570	0.5787019	0.800	1.0716601	1.030	1.7283798
0.115	0.0414006	0.345	0.2431469	0.575	0.5877645	0.805	1.0841500	1.035	1.7445682
0.120	0.0442474	0.350	0.2491026	0.580	0.5968989	0.810	1.0967174	1.040	1.7608400
0.125	0.0471671	0.355	0.2551252	0.585	0.6061050	0.815	1.1093625	1.045	1.7771953
0.130	0.0501588	0.360	0.2612149	0.590	0.6153829	0.820	1.1220854	1.050	1.7936343
0.135	0.0532222	0.365	0.2673716	0.595	0.6247330	0.825	1.1348861	1.055	1.8101570
0.140	0.0563565	0.370	0.2735954	0.600	0.6341551	0.830	1.1477649	1.060	1.8267635
0.145	0.0595615	0.375	0.2798865	0.605	0.6436496	0.835	1.1607219	1.065	1.8434541
0.150	0.0628365	0.380	0.2862449	0.610	0.6532164	0.840	1.1737572	1.070	1.8602288
0.155	0.0661812	0.385	0.2926706	0.615	0.6628558	0.845	1.1868709	1.075	1.8770877
0.160	0.0695953	0.390	0.2991638	0.620	0.6725678	0.850	1.2000631	1.080	1.8940310
0.165	0.0730784	0.395	0.3057246	0.625	0.6823525	0.855	1.2133341	1.085	1.9110589
0.170	0.0766302	0.400	0.3123531	0.630	0.6922102	0.860	1.2266838	1.090	1.9281713
0.175	0.08022504	0.405	0.3190493	0.635	0.7021409	0.865	1.2401125	1.095	1.9453685
0.180	0.0839387	0.410	0.3258133	0.640	0.7121448	0.870	1.2536203	1.100	1.9626506
0.185	0.0876950	0.415	0.3326452	0.645	0.7222220	0.875	1.2672072	1.105	1.9800176
0.190	0.0915190	0.420	0.3395452	0.650	0.7323725	0.880	1.2808735	1.110	1.9974698
0.195	0.0954105	0.425	0.3465132	0.655	0.7425966	0.885	1.2946192	1.115	2.0150072
0.200	0.0993694	0.430	0.3535495	0.660	0.7528944	0.890	1.3084445	1.120	2.0326299
0.205	0.1033955	0.435	0.3606541	0.665	0.7632659	0.895	1.3223496	1.125	2.0503382
0.210	0.1074887	0.440	0.3678272	0.670	0.7737114	0.900	1.3363344	1.130	2.0681321
0.215	0.1116488	0.445	0.3750688	0.675	0.7842309	0.905	1.3503992	1.135	2.0860117
0.220	0.1158757	0.450	0.3823789	0.680	0.7948246	0.910	1.3645441	1.140	2.1039771
0.225	0.1201694	0.455	0.3897579	0.685	0.8054926	0.915	1.3787693	1.145	2.1220286
0.230	0.1245297	0.460	0.3972056	0.690	0.8162350	0.920	1.39330747	1.150	2.1401661

ξ	Ψ	ξ	Ψ	ξ	Ψ	ξ	Ψ	ξ	Ψ
0.235	0.1289566	0.465	0.4047224	0.695	0.8270520	0.925	1.4074607	1.155	2.1583899
0.240	0.1334500	0.470	0.4123082	0.700	0.8379437	0.930	1.4219272	1.160	2.1767000
0.245	0.13890098	0.475	0.4199631	0.705	0.8489102	0.935	1.4364745	1.165	2.1950965
0.250	0.1426361	0.480	0.4276873	0.710	0.8599516	0.940	1.4511026	1.170	2.2135797
0.255	0.1473287	0.485	0.4354810	0.715	0.8710681	0.945	1.4658118	1.175	2.2321496
0.260	0.1520877	0.490	0.4433441	0.720	0.882598	0.950	1.4806020	1.180	2.2508063
0.265	0.1569130	0.495	0.4512768	0.725	0.8935269	0.955	1.4954734	1.185	2.2695499
0.270	0.1618046	0.500	0.4592793	0.730	0.9048694	0.960	1.5104263	1.190	2.2883806
0.275	0.1667625	0.505	0.4673517	0.735	0.9162875	0.965	1.5254606	1.195	2.3072986
0.280	0.1717868	0.510	0.4754940	0.740	0.9277813	0.970	1.5405765	1.200	2.3263038
0.285	0.1768773	0.515	0.4837063	0.745	0.9393510	0.975	1.5557742	1.205	2.3453965
0.290	0.1820342	0.520	0.4919889	0.750	0.9509966	0.980	1.5710537	1.210	2.3645767
0.295	0.172575	0.525	0.5003418	0.755	0.9627183	0.985	1.5864153	1.215	2.3838447
0.300	0.1925471	0.530	0.5087651	0.760	0.9745163	0.990	1.6018590	1.220	2.4032004
0.305	0.1979031	0.535	0.5172590	0.765	0.9863907	0.995	1.6173849	1.225	2.4226440
0.310	0.2033256	0.540	0.5258236	0.770	0.9983415	1.000	1.6329932	1.230	2.4421757
0.315	0.2088145	0.545	0.5344589	0.775	1.0103690	1.005	1.6486840	1.235	2.4617956
0.320	0.2143700	0.550	0.5431652	0.780	1.0224732	1.010	1.6644574	1.240	2.4815037
0.325	0.2199920	0.555	0.5519425	0.785	1.0346543	1.015	1.6803135	1.245	2.5013003
0.330	0.2256807	0.560	0.5607910	0.790	1.0469124	1.020	1.6962526	1.250	2.5211853

Where,

$$\Psi = \frac{Qm^{\frac{3}{5}}}{\sqrt{g}B^{\frac{2}{5}}} \quad \text{And,} \quad \xi = \frac{my_c}{B}$$

APPENDIX A 5.5 (A)
NOMOGRAM FOR MANNING'S FORMULA

NOMOGRAM FOR MANNING'S FORMULA FOR GRAVITY SEWERS FLOWING FULL AND MANNING'S N VALUE OF 0.013
 (For discharges from 1000 lpm to 1000000 lpm)

For other values of Manning's n the velocity and discharge will be inversely proportional.
 Example-Find the discharge and velocity of a sewer flowing full of diameter 900 mm, slope of 1 in 1,000 and a Manning's n value of 0.0125.

Answer-From the nomogram, $V = 0.90 \text{ m/s}$ and discharge = 35,000 lpm. For n value of 0.0125,
 $V = 0.90 \times 0.013/0.0125 = 0.94 \text{ m/s}$ & discharge = $35,000 \times 0.013/0.0125 = 36,400 \text{ lpm}$

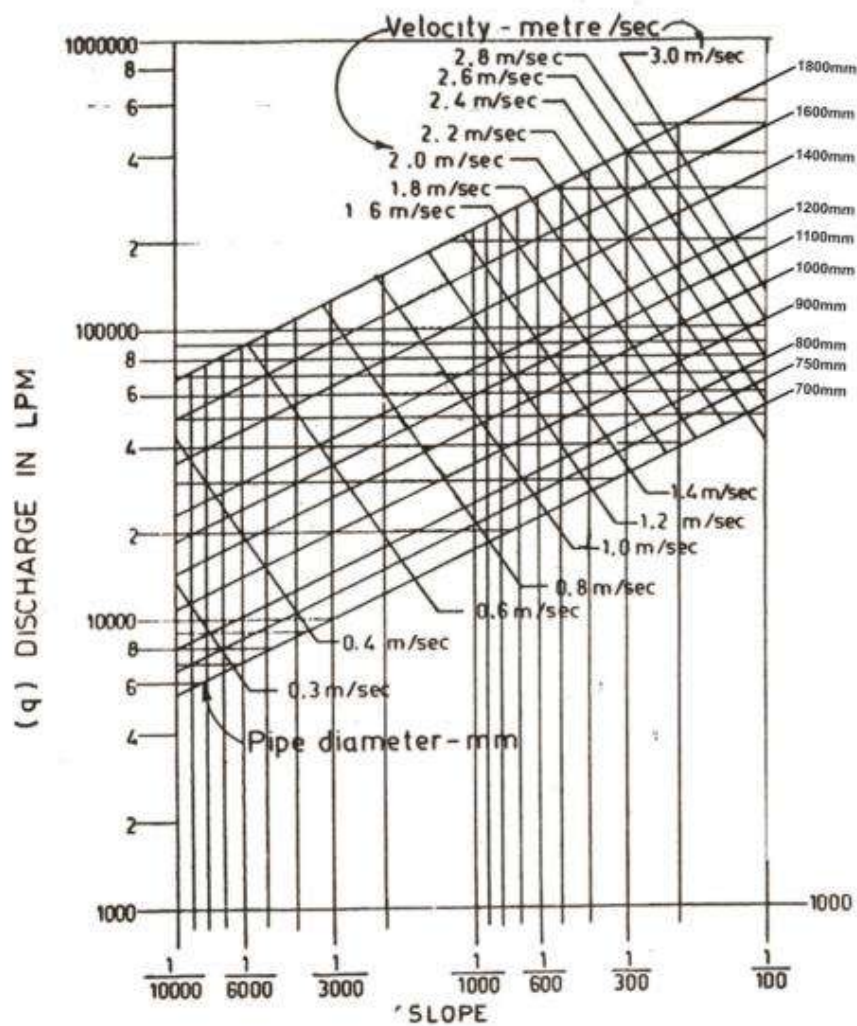

Source-“Manual on Sewerage and Sewage Treatment Systems”, CPHEEO, 2013

APPENDIX A 5.5 (B)
NOMOGRAM FOR MANNING'S FORMULA

NOMOGRAM FOR MANNING'S FORMULA FOR GRAVITY SEWERS FLOWING FULL AND MANNING'S N VALUE OF 0.013.

(For discharges from 100 lpm to 100000 lpm)

For other values of Manning's n, the velocity and discharge will be inversely proportional.

Example-Find the discharge and velocity of a sewer flowing full of diameter 200 mm, slope of 1 in 200 and a Manning's n value of 0.0125.

Answer-From the nomogram, $V = 0.75$ m/s and discharge = 1,300 lpm. For n value of 0.0125, $V = 0.75 \times 0.013/0.0125 = 0.78$ m/s & discharge = $1,300 \times 0.013/0.0125 = 1,352$ lpm

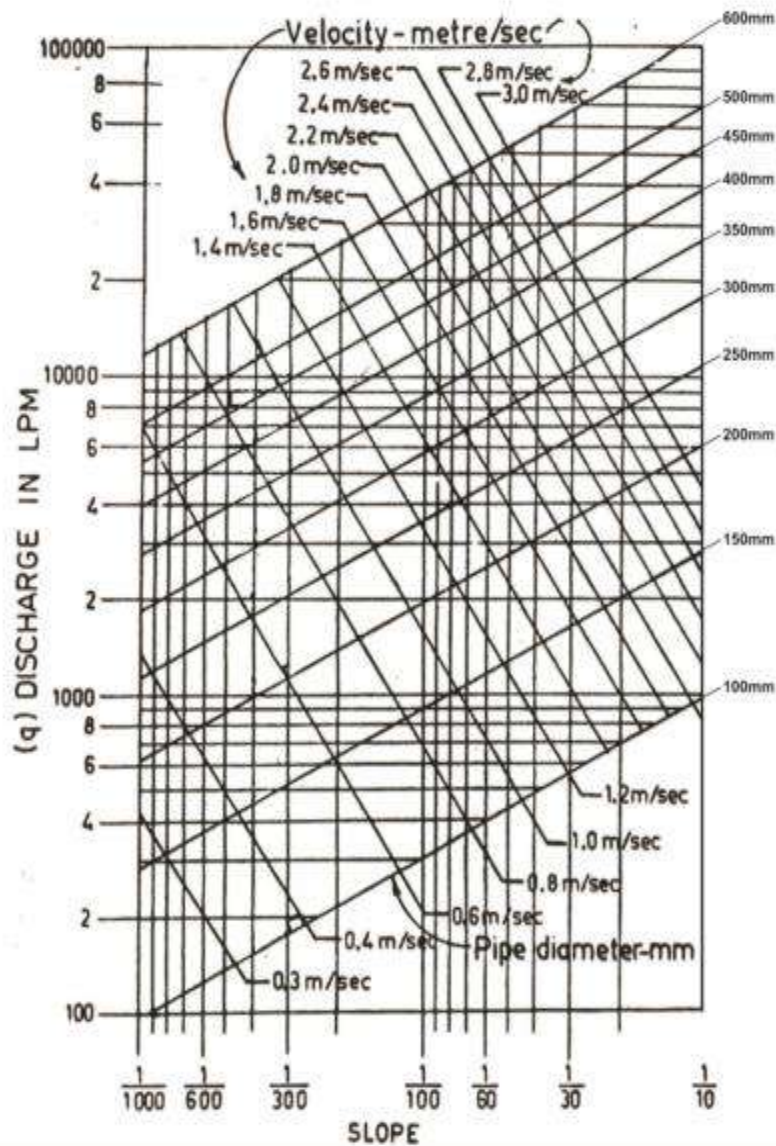

Source-“Sewerage Manual”, CPHEEO, 2013

**APPENDIX A 5.5 (C)
NOMOGRAM FOR HAZEN WILLIAMS FORMULA**

FOR MAINS FLOWING FULL AND C VALUE OF 100

(For discharges from 100 to 100000 lpm)

For other values of C, the velocity and discharge will be directly proportional.

Example-Find the discharge and velocity of a sewer of diameter 300 mm flowing full slope of 1 in 100 and a Hazen Williams C value of 130

Answer-From the nomogram, $V = 0.75$ m/s and discharge = 5,700 lpm. For C value of 130, $V = 0.75 \times 130 / 100 = 0.98$ m/s & discharge = $5,700 \times 130 / 100 = 7,400$ lpm

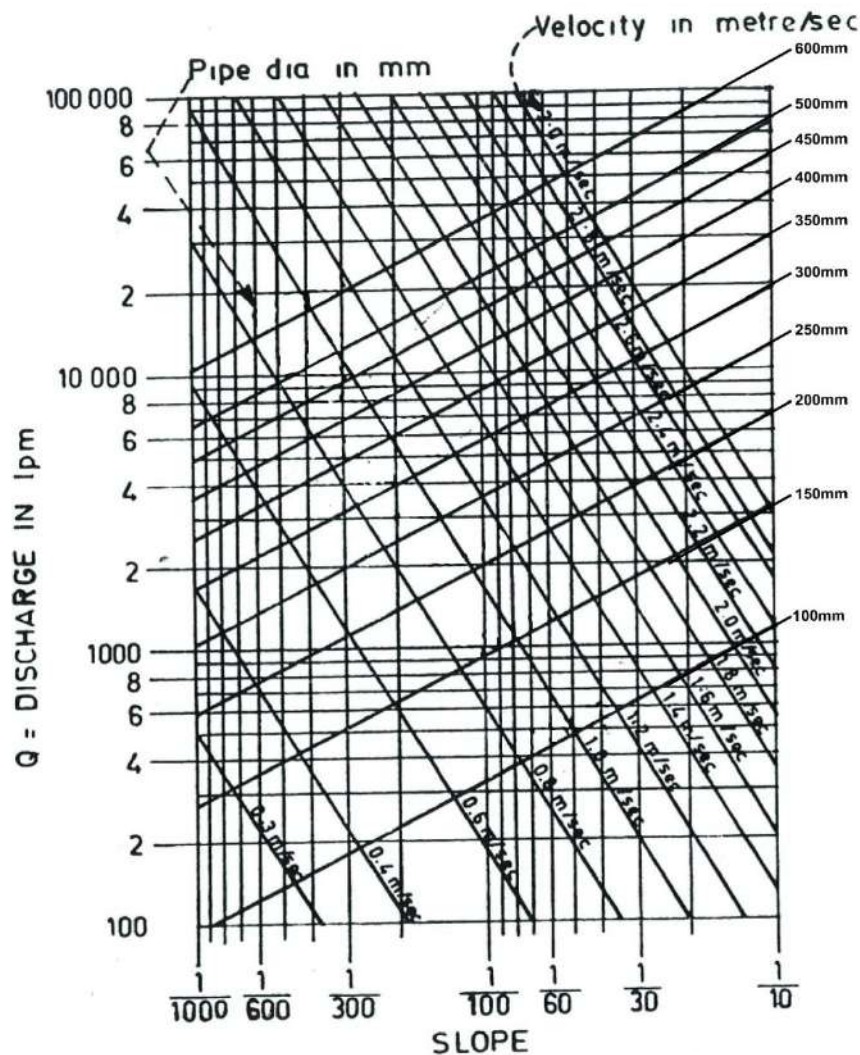

**FIG 3 NOMOGRAM CHART FOR HAZEN-WILLIAMS FORMULA
(C = 100) FOR Q = 100 lpm TO 100000 lpm**

Source: Sewerage Manual”, CPHEEO, 2013

**APPENDIX A 5.5 (D)
NOMOGRAM FOR HAZEN WILLIAMS FORMULA**

**FOR MAINS FLOWING FULL AND C VALUE OF 100
(For discharges from 1000 to 1000000 lpm)**

For other values of C the velocity and discharge will increase pro-rata.
Example-Find the discharge and velocity of a sewer flowing full of diameter 1,200 mm, slope of 1 in

1,000 and a Hazen Williams C value of 130

Answer-From the nomogram, V = 0.95 m/s and discharge = 63,000 lpm. For C value of 130,

$V = 0.95 \times 130 / 100 = 1.24 \text{ m/s}$ & discharge = $63,000 \times 130 / 100 = 81,900 \text{ lpm}$

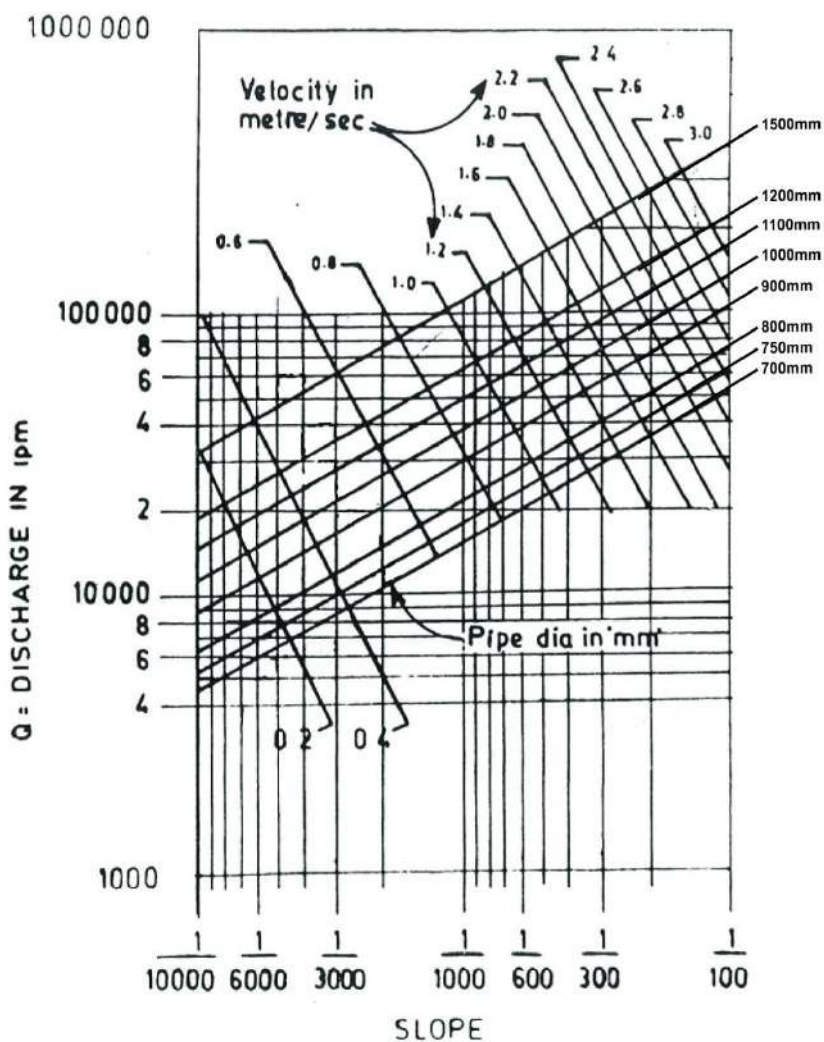

**FIG 4 NOMOGRAM CHART FOR HAZEN-WILLIAMS FORMULA
(C = 100) FOR Q = 1000 lpm TO 1000000 lpm**

Source: "Sewerage Manual", CPHEEO, 2013

APPENDIX A 5.6
MOODY DIAGRAM FOR OPEN CHANNEL FLOW

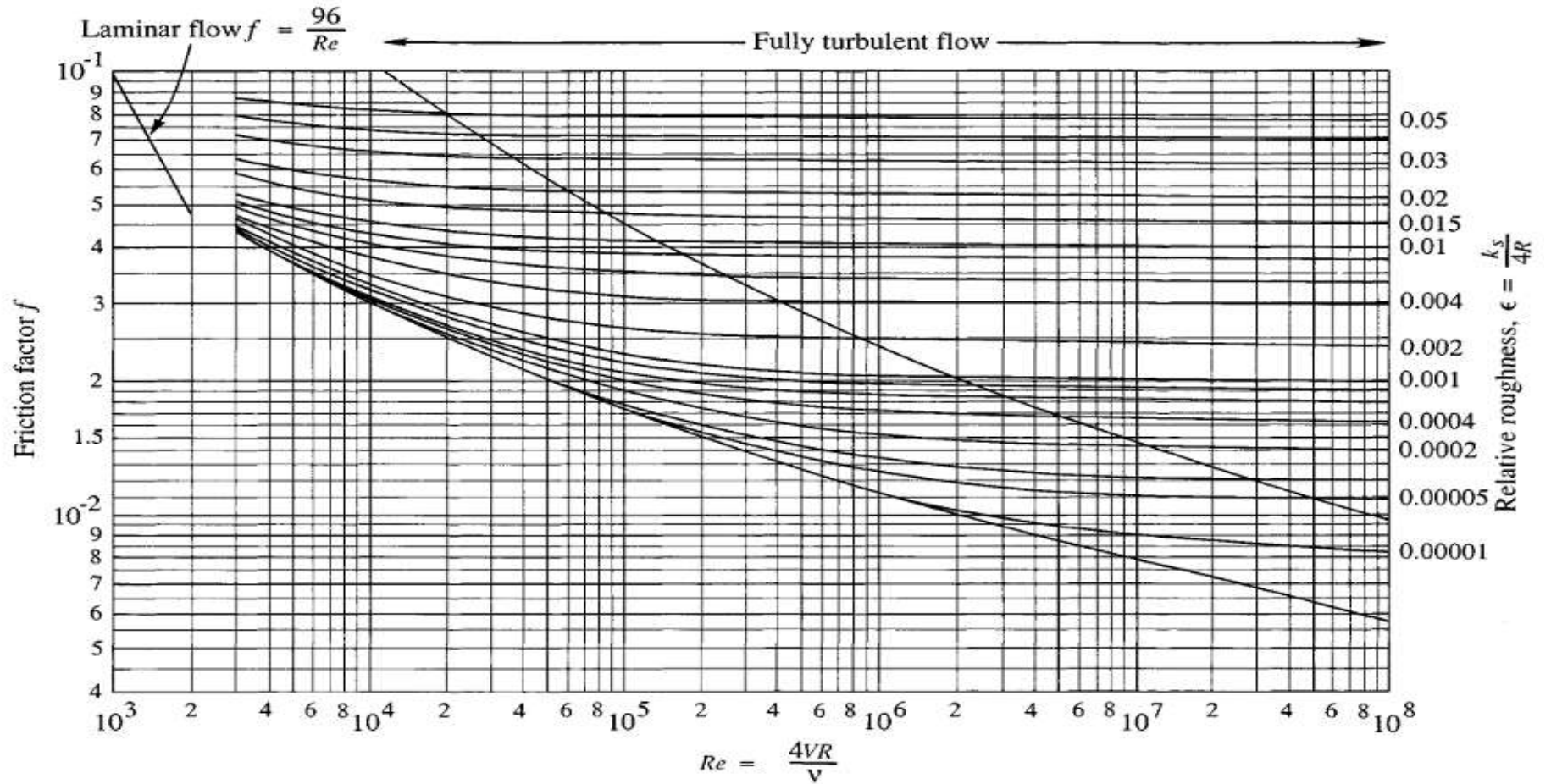

APPENDIX A 5.7
MANNING'S ROUGHNESS COEFFICIENT FOR OVERLAND FLOW

Source	Ground Cover	n	Range
Crawford and Linsley (1966)^a	Smooth asphalt	0.01	
	Asphalt of concrete paving	0.014	
	Packed clay	0.03	
	Light turf	0.20	
	Dense turf	0.35	
	Dense shrubbery and forest litter	0.4	
Engman (1986)^b	Concrete or asphalt	0.011	0.010-0.013
	Bare Sand	0.010	0.01-0.016
	Graveled surface	0.02	0.012-0.03
	Bare clay-loam (eroded)	0.02	0.012-0.033
	Range (natural)	0.13	0.01-0.32
	Bluegrass sod	0.45	0.39-0.63
	Short grass prairie	0.15	0.10-0.20
	Bermuda grass	0.41	0.30-0.48
Yen (2001)^c	Smooth asphalt pavement	0.012	0.010-0.015
	Smooth impervious surface	0.013	0.011-0.015
	Tar and sand pavement	0.014	0.012-0.016
	Concrete pavement	0.017	0.014-0.020
	Rough impervious surface	0.019	0.015-0.023
	Smooth bare packed soil	0.021	0.017-0.025
	Moderate bare packed soil	0.030	0.025-0.035
	Rough bare packed soil	0.038	0.032-0.045
	Gravel soil	0.032	0.025-0.045
	Mowed poor grass	0.038	0.030-0.045
	Average grass, closely clipped sod	0.050	0.040-0.060
	Pasture	0.055	0.040-0.070
	Timberland	0.090	0.060-0.120
	Dense grass	0.090	0.060-0.120
	Shrubs and bushes	0.120	0.080-0.180
	Business land use	0.022	0.014-0.035
	Semi-business land use	0.035	0.022-0.050
	Industrial land use	0.035	0.020-0.050
Dense residential land use	0.040	0.025-0.060	
Suburban residential land use	0.055	0.030-0.080	
Parks and lawns	0.075	0.040-0.120	
^a Obtained by calibration of Stanford Watershed Model.			
^b Computed by Engman (1986) by kinematic wave and storage analysis of measured rainfall-runoff data.			
^c Computed on basis of kinematic wave analysis.			

APPENDIX A 5.8 EXAMPLE ON DESIGN OF STORM WATER DRAINS

Design a system of storm water drains for residential colony situated in Safdurjang, New Delhi shown in Figure based on the Rational Formula for the estimation of peak runoff.

Basic Data and Assumptions

- Minimum velocity in drains : 0.8 mps
- Rainfall intensity = consider 5 year storm as the area is central and high priced.
- Use Table 3.7 for the record of rainfall intensity and frequency of rainfall.

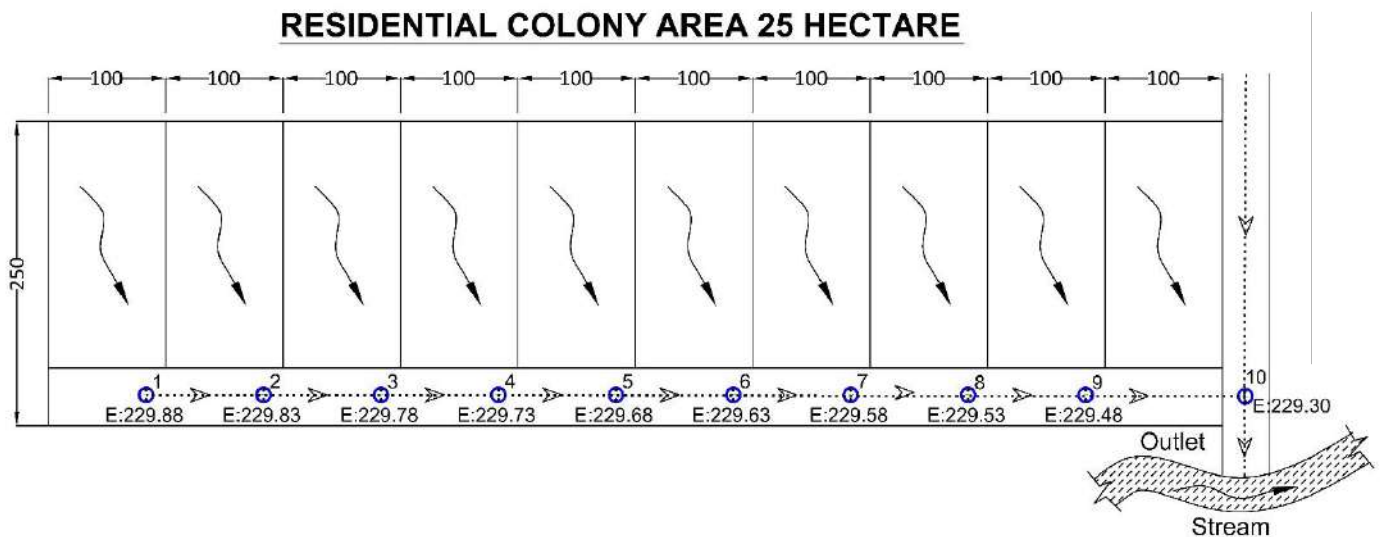

Design of Closed Conduit

Drain No	Location of Drain			Area of Catchment		Ground Profile		Weighted Runoff coeff @	Runoff Coeff. "C"	t _c time of concentration			Intensity of rainfall (mm/hr)	Runoff (Q) m ³ /hr	Runoff (Q) m ³ /sec	Manning's Coefficient	Length of Drain (m)	Slope of Drain	Dia (m)	Proposed Dia	Design Discharge m ³ /sec	Velocity (mps)		q/Q	v/V	d/D	Fall in Invert (m)	Upper end Ground level	Lower end Ground Level	Upper end invert level	Lower end invert Level
										(min)												Design Velocity	Actual Velocity								
										Time of (t _c) inlet	Time of flow in drain t _r	Total t _c = t _c + t _r																			
Street	Manhole / Junction from	Manhole / Junction to	Contributory Area	Total Area	Slope of Ground Level (1 in)	Overland flow Length (m)	10CIA	10	11	12	13	14	15	16	17	18	19	20	21	22	23	24	25	26	27	28	29	30	31	32	
1	MH 01	MH 02	2.5	2.5	2000	269.26	0.8	0.8	13.49	0	13.49	115.37	2307.5	0.641	0.013	100.000	1000	0.94	1.00	0.76	0.97	1.083	0.85	1.12	0.939	0.10	229.88	229.83	228.88	228.78	
2	MH 02	MH 03	2.5	5	2000	269.26	0.8	0.8	13.49	1.539	15.03	112.25	4489.9	1.247	0.013	100.000	1000	1.205	1.300	1.525	1.15	1.281	0.82	1.11	0.927	0.10	229.83	229.78	228.78	228.68	
3	MH 03	MH 04	2.5	7.5	2000	269.26	0.8	0.8	15.03	1.301	16.33	109.61	6576.3	1.827	0.013	100.000	1000	1.39	1.40	1.86	1.21	1.380	0.98	1.14	0.993	0.10	229.78	229.73	228.68	228.58	
4	MH 04	MH 05	2.5	10	2000	269.26	0.8	0.8	16.33	1.208	17.53	107.15	8572.2	2.381	0.013	100.000	1000	1.54	1.60	2.65	1.32	1.490	0.90	1.13	0.960	0.10	229.73	229.68	228.58	228.48	
5	MH 05	MH 06	2.5	12.5	2000	269.26	0.8	0.8	17.53	1.119	18.65	104.88	10487.9	2.913	0.013	100.000	1000	1.66	1.70	3.12	1.38	1.560	0.93	1.13	0.974	0.10	229.68	229.63	228.48	228.38	
6	MH 06	MH 07	2.5	15	2000	269.26	0.8	0.8	18.65	1.068	19.72	89.47	10736.5	2.982	0.013	100.000	1000	1.67	1.70	3.12	1.38	1.565	0.96	1.14	0.983	0.10	229.63	229.58	228.38	228.28	
7	MH 07	MH 08	2.5	17.5	2000	269.26	0.8	0.8	19.72	1.065	20.79	88.68	12415.1	3.449	0.013	100.000	1000	1.76	1.80	3.63	1.43	1.633	0.95	1.14	0.980	0.10	229.58	229.53	228.28	228.18	
8	MH 08	MH 09	2.5	20	2000	269.26	0.8	0.8	20.79	1.021	21.81	87.92	14067.2	3.908	0.013	100.000	1000	1.85	1.90	4.20	1.48	1.680	0.93	1.13	0.973	0.10	229.53	229.48	228.18	228.08	
9	MH 09	MH 10	2.5	22.5	2000	269.26	0.8	0.8	21.81	0.992	22.80	87.18	15692.9	4.359	0.013	100.000	1000	1.93	2.00	4.81	1.53	1.732	0.91	1.13	0.963	0.10	229.48	229.43	228.08	227.98	
10	MH 10	Outfall	2.50	25.0	2000	269.26	0.8	0.80	22.80	2.405	25.20	85.39	17078.9	4.744	0.013	250.000	1000	1.99	2.00	4.81	1.53	1.751	0.99	1.14	0.994	0.25	229.43	229.30	227.98	227.73	

Design of Open Channel Drain

Drain No	Location of Drain			Area of Catchment		Ground Profile		Weighted Runoff coeff @	Runoff Coeff. "C"	t _c time of concentration			Intensity of rainfall (mm/hr)	Runoff (Q) m ³ /hr	Runoff (Q) m ³ /sec	Manning's Coefficient	Length of Drain (m)	Slope of Drain	Depth (m)	Depth with Freeboard	Width (m)	Area	Section type	Section	Velocity (m/s)	Fall in Invert (m)	Upper end Ground level	Lower end Ground Level	Upper end invert level	Lower end invert Level	
										(min)																					Depth X Width
										Time of (t _c) inlet	Time of flow in drain t _r	Total t _c = t _c + t _r																			
Street	Manhole / Junction from	Manhole / Junction to	Contributory Area	Total Area	Slope of Ground Level (1 in)	Overland flow Length (m)	10CIA	10	11	12	13	14	15	16	17	18	19	20	21	22	23	24	25	26	27	28	29	30	31		
1	MH 01	MH 02	2.5	2.5	2000	269.26	0.8	0.8	13.49	0	13.49	115.37	2307.481	0.641	0.013	100.000	1000	0.56	0.76	1.11	0.62	Rectangular	0.76 X 1.11	1.04	0.10	229.88	229.83	228.88	228.78		
2	MH 02	MH 03	2.5	5	2000	269.26	0.8	0.8	13.49	1.608	15.09	112.11	4484.287	1.246	0.013	100.000	1000	0.71	0.91	1.43	1.02	Rectangular	0.91 X 1.43	1.22	0.10	229.83	229.78	228.78	228.68		
3	MH 03	MH 04	2.5	7.5	2000	269.26	0.8	0.8	15.09	1.362	16.46	109.34	6560.418	1.822	0.013	100.000	1000	0.82	1.02	1.65	1.35	Rectangular	1.02 X 1.65	1.35	0.10	229.78	229.73	228.68	228.58		
4	MH 04	MH 05	2.5	10	2000	269.26	0.8	0.8	16.46	1.239	17.70	106.82	8545.957	2.374	0.013	100.000	1000	0.91	1.11	1.82	1.65	Rectangular	1.11 X 1.82	1.44	0.10	229.73	229.68	228.58	228.48		
5	MH 05	MH 06	2.5	12.5	2000	269.26	0.8	0.8	17.70	1.159	18.85	104.47	10446.955	2.902	0.013	100.000	1000	0.98	1.18	1.96	1.92	Rectangular	1.18 X 1.96	1.51	0.10	229.68	229.63	228.48	228.38		
6	MH 06	MH 07	2.5	15	2000	269.26	0.8	0.8	18.85	1.103	19.96	89.30	10715.404	2.977	0.013	100.000	1000	0.99	1.19	1.98	1.96	Rectangular	1.19 X 1.98	1.52	0.10	229.63	229.58	228.38	228.28		
7	MH 07	MH 08	2.5	17.5	2000	269.26	0.8	0.8	19.96	1.096	21.05	88.48	12387.294	3.441	0.013	100.000	1000	1.04	1.24	2.09	2.18	Rectangular	1.24 X 2.09	1.58	0.10	229.58	229.53	228.28	228.18		
8	MH 08	MH 09	2.5	20	2000	269.26	0.8	0.8	21.05	1.057	22.11	87.70	14031.249	3.898	0.013	100.000	1000	1.09	1.29	2.19	2.39	Rectangular	1.29 X 2.19	1.63	0.10	229.53	229.48	228.18	228.08		
9	MH 09	MH 10	2.5	22.5	2000	269.26	0.8	0.8	22.11	1.024	23.13	86.93	15648.125	4.347	0.013	100.000	1000	1.14	1.34	2.28	2.60	Rectangular	1.34 X 2.28	1.67	0.10	229.48	229.43	228.08	227.98		
10	MH 10	Outfall	2.50	25.0	2000	269.26	0.8	0.8	23.13	2.491	25.63	85.20	17039.859	4.733	0.01	250.000	1000	1.18	1.38	2.35	2.77	Rectangular	1.37 X 2.34	1.71	0.25	229.43	229.30	227.98	227.73		

APPENDIX A 5.9

SWMM MODEL DESCRIPTION AND CASE STUDY

INTRODUCTION

The simulation of urban watershed and the management of its resources are performed by developing different hydraulic and rainfall-runoff methods. The complex behaviour of the urban system and their relations between the hydrological-hydraulic processes need to be explained first as per hydrological cycle i.e., how runoff is influenced by the considerable changes made in urban watershed characteristics. Storm Water Management Model (SWMM) is a dynamic rainfall-runoff model used for modelling quantity and quality of runoff for a single event or for a continuous storm in urban areas (Rossman, 2005). Rossman (2005) further reported that in SWMM, the study area is divided into number of small subareas which receives rainfall and generates surface runoff. There are number of modules present in SWMM, which are used to evaluate various elements of hydrological cycle. Mass balance principle and nonlinear reservoir approach are used by SWMM to evaluate surface runoff. Therefore, SWMM being a public domain model (provide here the link of the SWMM site), is a good option to be used for design and evaluation of a storm water system in an integrated manner.

THEORETICAL FRAMEWORK OVERVIEW

For the analysis of the urban system, it is necessary to have a mathematical model which represents the behavior of the systems. An overview of the theoretical framework to the modelling software SWMM has been given and modelling capabilities have been discussed in detail.

Rainfall-Runoff Routing

The flow is generated in SWMM by converting the excess rainfall into the overland flow (runoff).

The surface runoff which is generated from subareas is approximated as nonlinear reservoirs as shown in Figure. A.1.

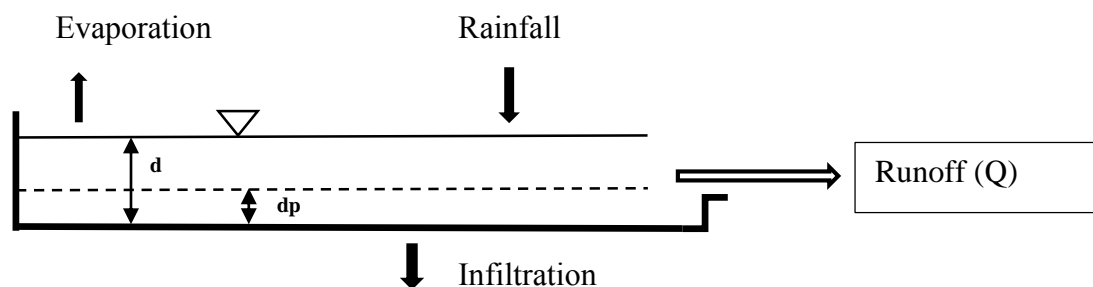

Figure. A.1. Nonlinear Reservoir Model Scheme

Continuity equation is coupled with Manning's equation to establish nonlinear reservoir. For subareas, continuity can be expressed as:

$$\frac{dV}{dt} = A * \frac{dd}{dt} = A * i^* - Q \quad (\text{A.1})$$

Where, $V = A \cdot d$ = water volume on the subarea, d = depth of water, t = time, A = sub-catchment area, i^* = excess rainfall and Q = runoff

Manning's equation is used for generating outflow:

$$Q = \frac{W}{n} (d - d_p)^{5/3} * S^{1/2} \quad (\text{A.2})$$

Where, W = width of the sub-catchment in m, n = coefficient of Manning's roughness, d_p = depression storage depth in mm, and S = slope of the sub-catchment in percentage

Nonlinear differential equation is obtained by combining the above two equations. At each time step, this nonlinear differential equation which is treated as nonlinear reservoir equation, can be computed using simple finite difference approach and can be estimated by:

$$\frac{d_2 - d_1}{\Delta t} = i^* WCON \left[d_1 + \frac{1}{2} * (d_2 - d_1) - d_p \right]^{5/3} \quad (\text{A.3})$$

$$\text{Where, } WCON = \frac{W * S^{1/2}}{A * n}$$

Infiltration

Mainly Green-Ampt (1911) or Horton (1933, 1940) are the two infiltration models used in pervious area for calculating infiltration as explained below. Time as the function of infiltration capacity is explained by Horton as:

$$f_p = f_c + (f_0 - f_c) * e^{-kt} \quad (\text{A.4})$$

Where, f_p = soil infiltration capacity, f_c = minimum or ultimate value of f_p , f_0 = maximum or initial value of f_p , t = storm starting time, and k = coefficient of decay.

The above equation is used to explain how the infiltration capacity decreases exponentially during dense storm. Second model is the Green-Ampt equation which is based on physical parameters. Mein Larson (1973) designed Green-Ampt equation which is a two stage model. In first step, the amount of water, F_s infiltrates into the surface till the surface becomes saturated is well predicted beforehand by the model. After that, in second stage, Green-Ampt equation is used to predict the infiltration capacity, f_p . Thus,

$$\text{For } F < F_s : f = I \text{ and } F_s = \frac{S_n * IMD}{\frac{i}{K_s} - 1} \text{ for } i > K_s \quad (\text{A.5})$$

$$F \geq F_s : f = f_p \text{ and } f_p = K_s \left[1 + \frac{S_n * IMD}{F} \right] \quad (\text{A.6})$$

where, f = rate of infiltration, f_p = capacity of infiltration, i = intensity of rainfall, F = cumulative infiltration volume, F_s = cumulative infiltration volume required to cause surface saturation, S_u = average capillary suction at the wetting front, IMD = initial moisture deficit for this event and K_s = hydraulic conductivity of saturated soil.

Moisture contents in the surface soil and amount of water infiltrated into the surface are linked to infiltration.

Depression Storage

Viessman et al. (1977) explained that depression storage may or may not exist in the subareas (both pervious and impervious); but if it exists then during storm, the depression storage will be filled (volume of water) first, before the generation of surface runoff. The volume of water collected in the depression storage is treated as losses or “initial abstraction” which is caused by the occurrences like evaporation, interception, surface ponding or surface wetting. In pervious area, depression storage is also treated as infiltration by few other models. In pervious area, infiltration and evaporation both take place, if depression storage is filled with water, it results into fast refilling. Whereas in case of impervious area only evaporation takes place, if depression storage is filled with water, it makes refilling process very slow.

Flow Routing

A conceptual overview of SWMM is shown in Figure. A.2. The figure shows the main features of SWMM, i.e., how the inlet hydrographs is routed using conduit networks, nodes and structure of flow divider of the drainage system to the outfalls.

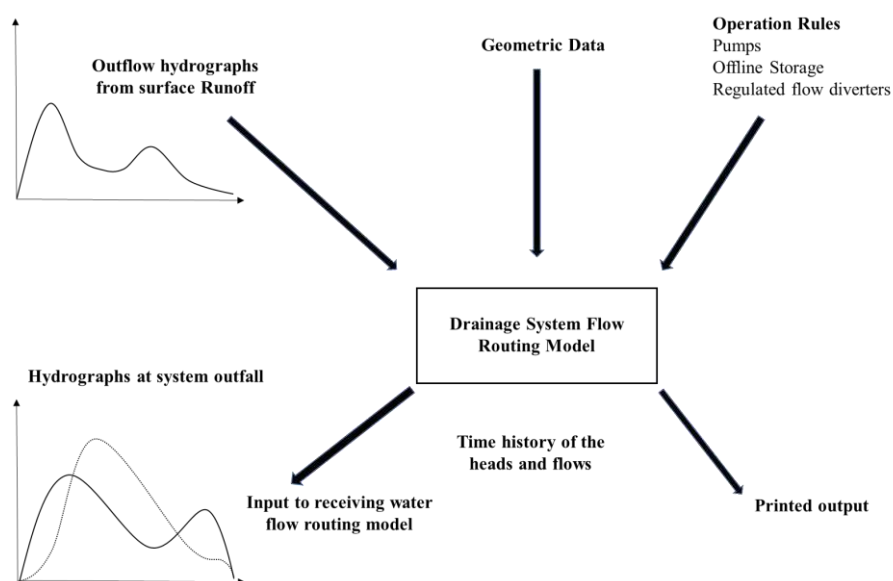

Figure. A.2: SWMM Module Functional Scheme

As shown in Figure. A.2, SWMM computes conduits (pipes, channels), nodes (manholes or junctions of conduits), orifices, weirs, detention storage (storage basins), pumps (on-line or off-line pump station), and outfall structures (transverse with or without tide gate, side-flow weir with tide gate, outfall with tide gate, free outfall without tide gate).

Output from SWMM:

- a) Represents the velocities and discharge hydrographs of any particular conduits both in plotted and printed form;
- b) Plot and print the water surface level and depth of flow of any junctions.

SWMM applies a link-node detailed explanation of the drainage system which facilitates the distinct illustration of the physical model and the mathematical solution of the Saint Venant equations (gradually-varied unsteady flow) which form the mathematical source of the model. The network of conduit is like a chain of pipes or channels which are joined at junctions or nodes. The transportation of flow takes place between junction to junction in conduits. Length, cross-sectional area, roughness coefficient, surface width and hydraulic radius are the properties related to conduits. The properties like cross-sectional area, surface width and hydraulic radius are the functions of the instant depth of flow. Discharge, Q is the main variable which depends on the characteristics of the conduits. The output of the model provides the average flow in every conduit, which is supposed to be constant over a time step. The model also gives other output results like flow depth, velocity of flow in of the conduits.

Junctions are the storage elements, which are also known as nodes or manholes in the physical drainage system. Surface area, volume and head are the properties related to junctions. Head, H is the main variable which changes with respect to time, but constant throughout the junction.

Inlet hydrographs as inflows and weir diversions as outflows occurs at the junctions of the perfect drainage system. Volume of water in the half-conduit length is equivalent at any time to the volume of water at the junctions when joined with any one junction. Calculations of discharge and head are based on the nodal volume changes during a known time step, Δt .

The simple differential equations for the storm flow issue derived from the steadily varied, unsteady flow equations for open channels, are also known as the St. Venants' or shallow water equations. Yen (1986) and Lai (1986) reported that the unsteady flow continuity equation with surface area flow is treated as dependent variables as:

$$\frac{\partial A}{\partial t} + \frac{\partial Q}{\partial x} = 0 \quad (\text{A.7})$$

where, A = area of cross sectional, Q = flow in conduit, x = distance along the pipe/channel, and t = time.

Lai (1986) gave the momentum equation as:

$$\frac{\partial Q}{\partial t} + \frac{\partial(Q^2/A)}{\partial x} + gA * \frac{\partial H}{\partial x} + gAS_f = 0 \quad (\text{A.8})$$

where, g = gravitational constant, $H = z + h$ = hydraulic head, z = invert level, h = depth of water, and S_f = friction (energy) slope.

In SWMM model, for the conduits, momentum equation is used; whereas, for the junctions, special lumped continuity equation is used. Therefore, conduits converse momentum and junctions converse continuity. Thus, the momentum equation is coupled with the continuity equations to produce an equation, which solves laterally every conduit at each time step

$$\frac{\partial Q}{\partial t} + gAS_f - 2V \frac{\partial A}{\partial t} - V^2 \frac{\partial A}{\partial x} + gA \frac{\partial H}{\partial x} = 0 \quad (\text{A.9})$$

where, Q = discharge along the conduit, V = conduit velocity, A = cross-sectional area of the flow, H = hydraulic head (invert elevation plus water depth), and S_f = friction slope.

Manning's equation is used for friction slope, i.e.

$$S_f = \frac{k}{gAR^{4/3}} Q |V| \quad (\text{A.10})$$

where, n = Manning's roughness coefficient, R = hydraulic radius, $k = gn^2$, g = gravitational acceleration.

Use of the absolute value on the sign on the flow term makes S_f a directional quantity and ensures that the friction force always opposes the flow.

Dynamic flow equation (final finite difference form) is obtained, when solved for $Q_{t+\Delta t}$ after substituting the value from equation A.9 to equation. A.10:

$$Q_{t+\Delta t} = \frac{1}{1 + \frac{k\Delta t}{R^{4/3}|V|}} \left[Q_t + 2\bar{V} \left(\frac{\Delta A}{\Delta t} \right)_t \Delta t + \bar{V}^2 \left[\left(\frac{A_2 - A_1}{L} \right) \right] \Delta t - g\bar{A} \left[\left(\frac{H_2 - H_1}{L} \right) \right] \Delta t \right] \quad (\text{A.11})$$

In the previous equation, V , R , and A are considered as weighted averages of the link and values at time t , and $(\Delta A/\Delta t)_t$ is the time derivative from the previous time step. $Q_{t+\Delta t}$, H_2 and H_1 are the basic unknowns in the equation (A.11). The various V , R , and A , are all associated with Q and H . Thus, an additional equation is needed for linking Q and H . This equation can be derived from the continuity equation at a junction:

$$\frac{\partial H}{\partial t} = \sum \frac{Q_t}{A_{st}} \quad (\text{A.12})$$

or in finite difference form

$$H_{t+\Delta t} = H_t + \sum \frac{Q_t \Delta t}{A_{s_t}} \quad (\text{A.13})$$

where, A_s = junction surface area

To compute discharge of each of the conduits and head of each of the junctions, the equation A.11 and A.13 can be solved at each time step Δt . The mathematical combination of the above two equations is accomplished by the enhanced polygon or by the revised Euler method (Rossman et al., 2004). The results obtained are reasonably precise and steady when some limitations were considered (Rossman et al., 2004). The equivalent half-step and full-step calculations for head are presented below:

Half-step at node j : Time $t+\Delta t/2$

$$H_j(t + \Delta t/2) = H_j(t) + (\Delta t/2) \left\{ \frac{1}{2} * \sum [Q(t) + Q(t + \Delta t/2)] + \sum [Q(t + \Delta t/2)] \right\} / A_{s_j}(t)$$

(A.14)

Full-step at node j : Time $t+\Delta t$

$$H_j(t + \Delta t) = H_j(t) + \Delta t \left\{ \frac{1}{2} * \sum [Q(t) + Q(t + \Delta t)] + \sum [Q(t + \Delta t)] \right\} / A_{s_j}(t) \quad (\text{A.15})$$

The entire succession of discharge calculations in the conduits and head calculations in the junctions are outlined as:

- Calculate half-step discharge at $t+\Delta t/2$ in every conduit, on the basis of earlier full step values of head at linking junctions.
- Calculate half-step flow transfers by orifices, pumps and weir at time $t+\Delta t/2$ on the basis of earlier full-step values of head at transfer junction.
- Calculate half-step head at every junction at time $t+\Delta t/2$ on the basis of average of earlier full step and present half-step discharges in every joining conduit, and above flow transfers at the present half-step.
- Calculate full-step discharge in every conduit at time $t+\Delta t$ on the basis of half-step heads at every linking junctions.
- Calculate full-step flow transfers among junctions at time $t+\Delta t$ on the basis of present half-step heads at every orifice, weir, and pump nodes.
- Calculate full-step head at time $t+\Delta t$ for every junctions on the basis of mean of earlier full-step and present full-step discharge, and above flow transfers at the present full-step.

The conduit-junction computations can be protracted to take into account of devices which avert sanitary sewage from the combined sewer system or reduce the storm burden from the sanitary interceptors. In SWMM model, entire diversions are

supposed to occur at junctions and are controlled as inter-nodal transfer. Devices like orifices, weirs (both side-flow and transverse), outfalls and pumps are treated as exceptional flow regulator devices in SWMM.

Flow Regulator Devices

Devices like in-line and off-line behaves as a flow regulator devices which provides the storage for storing excess runoff generated in the upstream, so as to mitigate as well as lag the flow hydrograph from the area upstream. Routing is executed by normal level-surface reservoir approach. Surge is not allowed in this type of storage.

Orifices

SWMM evaluates dropout or sump orifice and orifices at side outlet, by transforming the orifices to an equivalent pipe. The transformation is prepared as follows. The standard equation of orifice is:

$$Q_o = C_o A \sqrt{2gh} \quad (\text{A.16})$$

where, C_o = coefficient of discharge, A = cross-sectional area of the orifice, g = acceleration due to gravity, and h = the hydraulic head on the orifice.

When orifice is converted into a pipe, manning's pipe flow equation and orifice discharge equation is equated by the program, i.e.

$$\frac{1}{n} AR^{\frac{2}{3}} S^{\frac{1}{2}} = C_o A \sqrt{2gh} \quad (\text{A.17})$$

where, S = equivalent pipe slope.

Weirs

Flow over a weir is calculated by:

$$Q_w = C_w L_w \left[\left(\frac{h+V^2}{2g} \right)^a - \left(\frac{V^2}{2g} \right)^a \right] \quad (\text{A.18})$$

where, C_w = coefficient of discharge, L_w = length of weir (transverse to overflow), h = driving head on the weir, V = approach velocity, and a = weir exponent, $3/2$ for transverse weirs and $5/3$ for side flow weirs

For the submerged weir, calculation of the flow is done as:

$$Q_w = C_{SUB} C_w L_w (Y_l - Y_c)^{3/2} \quad (\text{A.19})$$

The coefficient of submergence, C_{SUB} , is taken from Roessert's Handbook of Hydraulics. C_{SUB} is a function of C_{RATIO} which is defined as:

$$C_{RATIO} = \frac{Y_2 - Y_c}{Y_1 - Y_c} \quad (\text{A.20})$$

In SWMM, the values are calculated spontaneously for C_{RATIO} and C_{SUB} and no initial information is required. The weir acts as orifice, when the weir is surcharged and the flow is calculated as:

$$Q_w = C_{SUR} L_w (Y_{TOP} - Y_c) \sqrt{2gh'} \quad (A.21)$$

where, Y_{TOP} = distance to top of weir opening, $h' = Y_1 - \text{maximum}(Y_2, Y_c)$, C_{SUR} = weir surcharge coefficient and L_w = length of weir (transverse to overflow).

The coefficient of weir surcharge, C_{SUR} , is calculated spontaneously, when the weir starts surcharging.

Pump stations

A pump station is theoretically characterized as either an in-line lift station or an off-line junction which represents as reservoirs or wet-well, from where the water is forced to other junction as per the planned rule curve in the system. Otherwise, the pumps can use a 3 point pump curve (head versus pumped outflow) for in-line as well as for off-line junction.

SWMM APPLICATIONS, LIMITATIONS AND ADVANTAGES

Advantages of SWMM Model

The key advantages of the SWMM software for catchment analysis are as follows:

- i. Since its development in the early 1970's, the SWMM hydraulic engine has been widely used for modelling stormwater and wastewater in North America. There are several other readily available software packages which use SWMM engine as their basis. USEPA maintain the SWMM software. SWMM is a globally well-accepted model.
- ii. SWMM is open source software and is freely downloadable. The modeller or the consultants have the right to modify the software as per their requirements, without any need to purchase the software.
- iii. The interface of SWMM is very simple and also has in-built data management abilities. The model also has robust hydraulic performance.
- iv. The SWMM model developed by USEPA, its user interface can be represented in more user friendly forms in the software such as MIKE URBAN, H20MAP SWMM, PCSWMM and XP-SWMM etc. More complex management of data, presentation of results features are also available in this software.

Limitations of SWMM Model

There are several limitations in SWMM, which are listed below.

- i. **GIS Linkages** - the SWMM model has no direct GIS linkages, i.e., not compatible with GIS.

- ii. **Simulation Speed** - As compared with the other hydraulic engines, the model hydraulic engine is somewhat slower. Continuous up gradation is in process which will improve the model performance steadily.

SWMM Model Applications

SWMM has been used widely worldwide by many researchers (for wastewater and stormwater). Distinct applications comprises of:

- i. Used in designing and classifying the dimensions of the drainage system
- ii. Used for the sizing of detention services and their trappings for controlling the flood control and also for safety of water quality.
- iii. Used in natural channel systems for identification of the flood plain.
- iv. For dual system, the model can reduce the overflows for planning proper control policies.
- v. In sanitary sewer, the effect of infiltration and inflow is estimated on overflows
- vi. For the study of the allocation of waste load, the model generates non-point source pollutant loadings
- vii. To study the reduction in pollutant loading in wet weather, the model has the capabilities to estimate the effectiveness of BMPs.

EXAMPLE - NETWORK 1

The objective of this section is to serve as a practical application guide for new SWMM users who have already had some previous training in hydrology and hydraulics. It contains two worked out examples that illustrate how SWMM can be used to model some of the most common types of design problems encountered in practice.

This first example illustrates the procedure to build a hydrologic and hydraulic model of an already built-up catchment, which is more usual case. It explains the procedure of spatially dividing a catchment into smaller computational elements, called subcatchments, and deliberates the characteristics of these subcatchments that SWMM uses to convert rainfall into runoff. This example also considers flow routing of runoff through the drainage pipes and channels contained within the catchment.

SYSTEM REPRESENTATION

SWMM is a distributed model, which means that a study area can be subdivided into any number of subcatchments to best capture the effects of spatial variability in topography, drainage pathways, land cover, and soil characteristics on runoff generation. An idealized subcatchment is conceptualized as a rectangular surface that has a uniform slope and a width W that drains to a single outlet channel as shown in Figure B.1. Each subcatchment can be further divided into three subareas: an impervious area with depression (detention) storage, an impervious area without depression storage and a pervious area with depression storage. SWMM also models a conveyance network as a series of nodes connected by links. Links control the rate of flow from one node to the next and are typically conduits (e.g. open channels or pipes) but additional controls such as orifices, weirs or pumps can also be implemented. The nodes define the elevation of the drainage system and the time-varying hydraulic head applied at the end of each link it connects. The flow conveyed through the links and nodes of the model is ultimately discharged to a final node called the outfall. Outfalls can be subjected to alternative hydraulic boundary conditions (e.g. free discharge, fixed water surface, time varying water surface, etc.) when modelled with Dynamic Wave.

In this example, a drainage system for a 750.28 ha urban catchment has been modelled. The system layout is shown in the Figure B.1. The area is divided into 120 subcatchments. The network consists of 119 stormwater conduits, 1 pump and 118 junction nodes where flows from subcatchments enter the system. The system discharges to an outfall into an open drain, known as Najafgarh drain, in NCT of Delhi.

First step in this direction shall involve delineation of the area into subcatchments draining various natural drains and evaluate the various properties for each of these subcatchments to evaluate overland flow. The next step shall involve computation of the flow corresponding to a specific storm event.

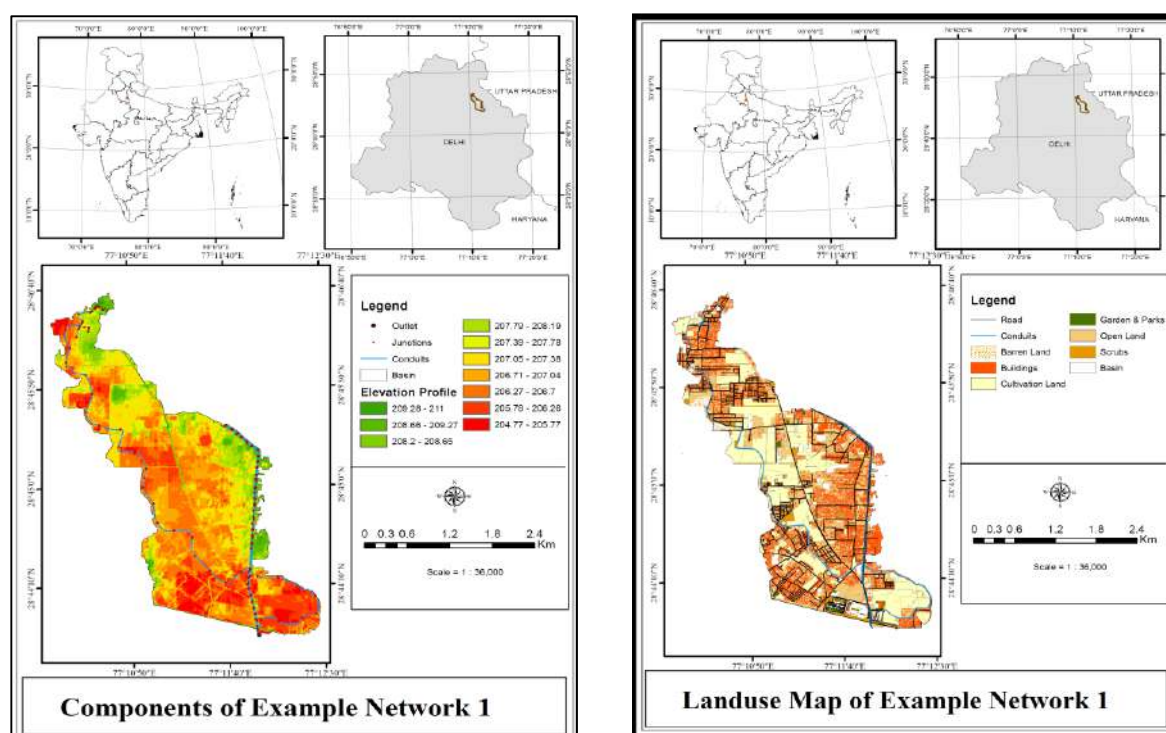

Figure B.1. Example Network Component and Land use

BASINS Based Subcatchments Division Approach for SWMM

The U.S. Environmental Protection Agency's (EPA's) Better Assessment Science Integrating point and Nonpoint Sources (BASINS) is a multipurpose model organised to support environmental and ecological studies in a drainage basin. In this study, the delineation capability of the BASINS model is used to delineate the sub-catchments to be used in the SWMM model. Numerous GIS data layers such as land use, digital elevation grids, and urban systems are needed to formulate the delineation and capture various properties within the subcatchments. The digital elevation model is an input to the BASINS to automatically delineate the subcatchments. These delineated subcatchments are used in the SWMM model. BASINS package is already integrated with the ArcGIS software and has recently developed a SWMM linkage as well. This link would be a valuable tool for urban planners and watershed managers to estimate the futuristic view of drainage system. The BASINS/SWMM Plugin is also useful in combining with existing GIS shapefiles of subcatchments, conduits, and nodes, if available for a present storm water system. Otherwise, the GIS layers of subcatchments, conduits, and nodes may also be formed using the BASINS watershed delineation and/or shapefile editing tools.

Subcatchment division

To divide the study area into subcatchment, 120 nodes were primarily identified based on the natural watershed obtained from BASINS model, the subcatchments were then delineated with the Thiessen polygons method which has the junction as its centre. With this division, the basic parameters of every subcatchment could be derived including area, width, average slope and rate of impervious area.

Project Setup

The first task is to create a new SWMM project which also enables certain default options.

The workflow of the project is explained below:

- Launch EPA SWMM if it is not previously running and select File >> New from the Main Menu bar to create a new project
- Select Project >> Defaults to open the Default Project.
- On the ID Labels, set the ID Prefixes as shown in Figure B.2. This will make SWMM automatically label new objects.

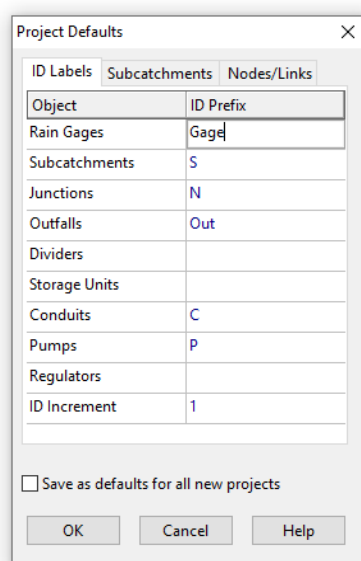

Figure B.2. Default ID labelling

- On the Subcatchments section set the following default values: **Dstore-Imperv.** 0.05, **Dstore-Perv** 0.05, **%Zero Imperv.** 25, **Infiltration Model** - HORTON
- On the Nodes/Links section, set the Units to CMS
- Click OK to accept these adoptions
- Next, fix some map display selections so that IDs and symbols will be displayed.
- Select Tools>> Map Display to bring up the Map Options box (Figure B.3).
- Select the Subcatchments, set the Fill Style and the Symbol Size
- Then select the Nodes and set the Node Size

- Select the Annotation and check on the display ID labels for Subcatchments, Nodes, and Conduits
- Finally select the Flow Arrow, select the Fancy arrow, and set the arrow size. Click the OK button to accept these selections.

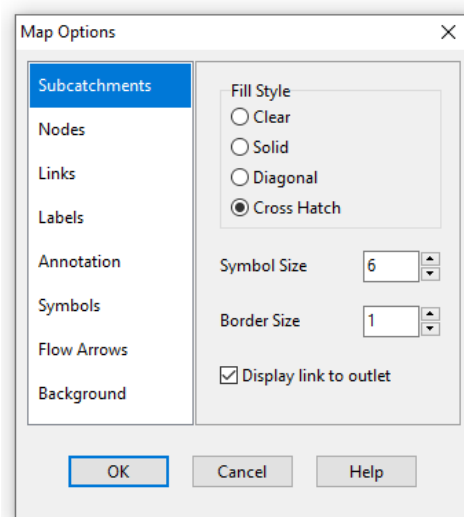





Figure B.3. Map Options dialog box

- The system is now ready to begin adding components (Subcatchments, Conduits, Junction, Outfall etc.) to the Study Area Map.
- The first in line should be the subcatchments.
- Start by clicking the  button on the Object Toolbar.

Move the mouse to the map where one of the corners of the subcatchment lies and left click the mouse, do the same for the next corners and then right click the mouse to close the shape that represent the subcatchment. This process allows the user to adjust the automatically delineated subcatchments using the natural terrain with respect to the manmade changes made/to be made to the natural system.

- Press the Esc key, if want to cancel the partially drawn subcatchment.
- Next, add in the junction and the outfall that comprise the drainage system.
- To begin adding junctions, click the  button on the Object Toolbar
- Move the mouse to the position of junction and left click it. Do the same for other junctions.
- To add the outfall, click the  button on the Toolbar, move the mouse to the outfall site on the map, and left click.
- At this point your map should look something like that shown in Figure B.4.

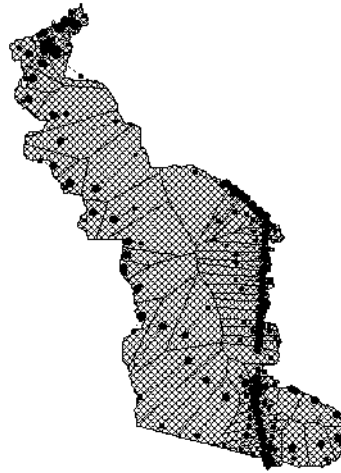



Figure B.4. Subcatchments and nodes for the study area

- Now, add the storm sewer conduits that connect the drainage system nodes to one another. Begin with conduit first, which connects junction 1 to 2.
- Click the  button on the Object Toolbar.
- Click the mouse on junction1 and move the mouse over to junction 2 and left click to create the conduit.
- One could have cancelled the action by either right clicking or by striking the Esc key
- Repeat this procedure for conduits 2 and so on.
- It is possible to draw a curved conduit by leftclicking at midway points where the path of the conduit changes before clicking on the end node.
- At this point the map should look something like that shown in Figure B.5.

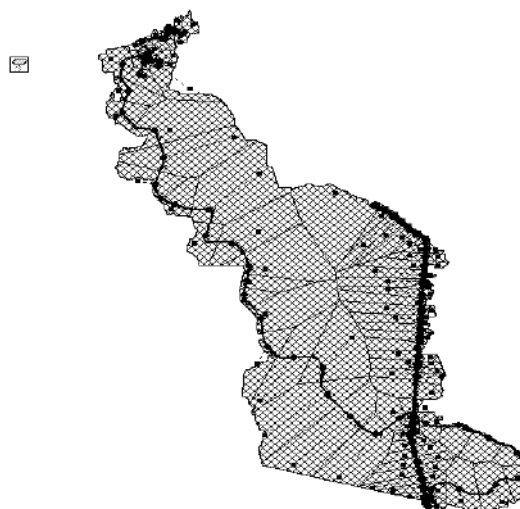





Figure B.5. Subcatchments, nodes, Rain gage and Conduits for the study area

- Click the Rain Gage  button on the Object Toolbar
- Move the mouse on the Study area Map to where the rain gage is located and left click the mouse.
- If rain gage, subcatchment or node is out of position one can move it by doing the following:
- If the  button is not previously depressed, click it to place the map in Object Selection mode.
- Click on the object to be relocated.
- Drag the object with the left mouse button held down to its new position. To re style a subcatchment:
- With the map in Object Selection mode, click on the subcatchment's centroid to select it.
- Then click the  button on the Map toolbar to put the map into Vertex Selection.
- Select a vertex point on the subcatchment outline by clicking on it.
- Drag the vertex to its new position with the left mouse button held down.
- If required, more vertices can be added or deleted by right clicking the mouse. When finished, click the button to return to object mode.
- This same process can also be used to reshape a conduit.

Setting Object Properties

- To change the value of a specific property for an object we must select the object into the Property Editor (Figure B.6).
- If the Editor is noticeable, then one can just click on the object or select it from the Data page if the Browser Panel of the main window & the Editor is not noticeable then we can make it appear by one of the following actions:
- Double-click the object on the map, or right click on the object and select Properties from the Popup menu, or select the object from the Data page of the Browser panel.
- Two key properties of the subcatchments that need to be set are the rain gage and the node of the drainage system.

Property	Value
Name	C_100
X-Coordinate	712622.496
Y-Coordinate	3185109.420
Description	
Tag	
Rain Gage	1
Outlet	1
Area	2.65
Width	33.30
% Slope	0.001
% Imperv	41.25
N-Imperv	0.0122
N-Perv	0.150
Dstore-Imperv	0.05
Dstore-Perv	0.05
%Zero-Imperv	25
Subarea Routing	OUTLET
Percent Routed	100
Infiltration	HORTON

User-assigned name of subcatchment

Figure B.6. Subcatchment inputs for the study area

- Since the outlet nodes vary by subcatchment, one must set them individually as Type 1 in the Outlet field and press Enter.
- Similarly set the area, percent imperviousness and width as shown below.

Table B.1. Input data to the Subcatchment

Conduit Name	Rain Gage	Outlet	Area	%Impervious	Width	%Slope	N-Impervious (manning)	N-Pervious (manning)
C_1	1	40	27.95	24.41	616	0.831	0.012	0.156
C_2	1	48	5.22	16.65	521.4	1.138	0.012	0.167
C_3	1	25	34.9	27.61	609.5	0.277	0.012	0.152
C_4	1	16	2.24	63.94	80.9	0.001	0.012	0.150
C_5	1	82	0.2	39.73	127.1	3.386	0.012	0.150
C_6	1	52	39.54	23.75	52.2	1.228	0.012	0.156
C_7	1	30	28.53	7.36	568.5	0.485	0.012	0.164
C_8	1	27	8.99	22.77	610.8	0.346	0.012	0.127
C_9	1	34	26.32	8.31	604.6	0.683	0.012	0.159
C_10	1	90	0.83	63.18	170.8	4.239	0.012	0.150
C_11	1	45	7.3	25.81	614.6	1.084	0.012	0.157
C_12	1	39	37.96	36.26	605.6	0.829	0.012	0.157
C_13	1	36	27.04	21.8	606.2	0.749	0.012	0.154
C_14	1	50	13.72	6.68	670.4	1.206	0.012	0.167
C_15	1	106	1.53	18.56	175	6.591	0.012	0.159
C_16	1	107	1.04	65.25	208.9	5.259	0.012	0.153
C_17	1	101	2.15	26.84	176	5.699	0.012	0.150
C_18	1	102	1.62	60.36	191.7	6.109	0.012	0.151

Conduit Name	Rain Gage	Outlet	Area	%Impervious	Width	%Slope	N-Impervious (manning)	N-Pervious (manning)
C_19	1	49	12.93	31.21	645.2	1.177	0.012	0.163
C_20	1	46	8.44	2.6	607.4	1.113	0.012	0.169
C_21	1	51	3.07	13.89	411.7	1.218	0.012	0.175
C_22	1	53	0.55	2.79	72.1	1.244	0.012	0.149
C_23	1	114	1.19	1.38	158.7	1.059	0.012	0.138
C_24	1	114	0.15	3.75	117	8.55	0.012	0.150
C_25	1	119	0.39	6.45	226.5	10.765	0.012	0.152
C_26	1	118	0.42	16.21	199.9	10.037	0.012	0.144
C_27	1	113	1.34	4.05	197.1	8.266	0.012	0.130
C_28	1	117	1.77	22.92	182.4	10.332	0.012	0.161
C_29	1	112	2.65	0.76	199.1	7.636	0.012	0.150
C_30	1	111	4.42	5.99	175.5	7.198	0.012	0.166
C_31	1	116	2.86	9.33	196.2	9.133	0.012	0.169
C_32	1	110	4.9	6.66	188.5	7.145	0.012	0.153
C_33	1	115	2.88	2.44	208.7	8.056	0.012	0.167
C_34	1	109	3.51	7.94	196.2	7.929	0.012	0.159
C_35	1	105	2.91	26.77	203.3	6.543	0.012	0.157
C_36	1	100	2.84	0.37	208.8	5.529	0.012	0.150
C_37	1	47	4.6	2.82	613.7	1.117	0.012	0.168
C_38	1	44	4.5	42.95	424.7	0.991	0.012	0.150
C_39	1	95	0.91	54.91	190.2	5.213	0.012	0.150
C_40	1	96	1.24	64	82.5	5.222	0.012	0.150
C_41	1	97	1.79	77.63	211.6	5.245	0.012	0.150
C_42	1	71	5.84	42.06	331.8	2.63	0.012	0.145
C_43	1	98	2.44	90.67	174.8	5.252	0.012	0.150
C_44	1	72	3.91	33.74	183.3	2.665	0.012	0.150
C_45	1	73	4.28	54.83	196	2.735	0.012	0.150
C_46	1	74	4.17	67.54	198	2.739	0.012	0.150
C_47	1	75	11.16	75.49	770.9	2.772	0.012	0.150
C_48	1	43	0.75	56.24	87.9	0.859	0.012	0.150
C_49	1	99	0.09	3.12	163.2	5.317	0.012	0.150
C_50	1	108	0.64	48.94	68	0.707	0.012	0.150
C_51	1	42	2.34	42.63	759	0.856	0.012	0.150
C_52	1	104	0.58	1.84	239	6.384	0.012	0.150
C_53	1	103	0.9	8.21	204.5	6.318	0.012	0.150
C_54	1	41	7.72	37.59	397.9	0.855	0.012	0.154
C_55	1	38	39.53	34.14	612.2	0.817	0.012	0.156
C_56	1	37	31.75	33.23	632	0.783	0.012	0.155
C_57	1	35	12.53	33.48	598.5	0.707	0.012	0.147
C_58	1	31	33.64	2.2	457.3	0.567	0.012	0.164
C_59	1	32	7.85	0.74	299.6	0.571	0.012	0.167
C_60	1	33	4.31	7	454.4	0.678	0.012	0.142

Conduit Name	Rain Gage	Outlet	Area	%Impervious	Width	%Slope	N-Impervious (manning)	N-Pervious (manning)
C_61	1	86	0.43	32.77	133.7	3.792	0.012	0.150
C_62	1	87	0.18	20.18	84.9	3.941	0.012	0.150
C_63	1	62	5.18	45.55	238.7	1.818	0.012	0.153
C_64	1	88	0.86	42.69	264.7	4.097	0.012	0.150
C_65	1	89	0.88	77.86	229.6	4.106	0.012	0.150
C_66	1	63	7.9	24.2	224.3	1.874	0.012	0.157
C_67	1	64	7.13	44.33	91.5	1.885	0.012	0.150
C_68	1	65	5.55	41.69	164.3	1.971	0.012	0.151
C_69	1	91	0.37	38.46	177.7	4.354	0.012	0.150
C_70	1	92	0.45	37.56	191.1	4.711	0.012	0.150
C_71	1	66	7.7	27.04	321.4	2.067	0.012	0.152
C_72	1	67	7.26	44.26	193.1	2.101	0.012	0.151
C_73	1	93	0.31	31.56	214	4.772	0.012	0.150
C_74	1	68	5.66	63.5	73.3	2.128	0.012	0.150
C_75	1	94	0.47	43.32	168.5	4.841	0.012	0.150
C_76	1	69	5.03	50.3	323.6	2.226	0.012	0.150
C_77	1	70	4.84	60.91	239.6	2.521	0.012	0.150
C_78	1	83	0.57	71.36	172.1	3.506	0.012	0.150
C_79	1	84	1.52	50.06	166.3	3.611	0.012	0.150
C_80	1	85	1.1	47.42	179.2	3.674	0.012	0.150
C_81	1	60	1.45	40.96	198.7	1.612	0.012	0.166
C_82	1	61	2.46	32.56	164.8	1.785	0.012	0.151
C_83	1	59	0.65	51.12	268.9	1.549	0.012	0.150
C_84	1	81	0.25	56.77	215.8	3.222	0.012	0.150
C_85	1	58	2.2	62.18	148.1	1.412	0.012	0.151
C_86	1	57	5.82	57.47	212.6	1.403	0.012	0.152
C_87	1	80	0.36	21.83	145.8	3.093	0.012	0.150
C_88	1	79	0.21	54.05	179	3.047	0.012	0.150
C_89	1	56	4.31	22.47	178.1	1.375	0.012	0.152
C_90	1	78	0.27	45.24	176.4	3.007	0.012	0.150
C_91	1	55	6.68	39.76	167.5	1.352	0.012	0.156
C_92	1	54	3.02	34.62	209.2	1.324	0.012	0.150
C_93	1	77	0.31	31.62	62.5	2.903	0.012	0.150
C_94	1	76	0.33	10.23	176	2.818	0.012	0.150
C_95	1	28	45.5	12.62	648.9	0.383	0.012	0.156
C_96	1	29	9.43	0.4	623.9	0.401	0.012	0.165
C_97	1	26	9.79	14.57	598.6	0.311	0.012	0.125
C_98	1	24	31.2	30.43	678.2	0.273	0.012	0.157
C_99	1	23	7.64	32.51	605.6	0.256	0.012	0.150
C_100	1	1	2.65	41.25	33.3	0.001	0.012	0.150
C_101	1	2	1	0.69	97.7	0.001	0.012	0.150
C_102	1	3	0.7	59.75	94.2	0.001	0.012	0.150

Conduit Name	Rain Gage	Outlet	Area	%Impervious	Width	%Slope	N-Impervious (manning)	N-Pervious (manning)
C_103	1	4	0.68	57.03	46.5	0.001	0.012	0.150
C_104	1	5	0.26	44.97	38	0.001	0.012	0.150
C_105	1	6	0.16	28.47	39.5	0.001	0.012	0.150
C_106	1	7	0.5	30.37	77.7	0.001	0.012	0.150
C_107	1	8	1.12	46.06	89.9	0.001	0.012	0.158
C_108	1	9	1.71	20.87	198.6	0.001	0.012	0.152
C_109	1	15	0.64	1.42	240.7	0.001	0.012	0.150
C_110	1	14	7.75	57.14	48.3	0.001	0.012	0.154
C_111	1	17	0.58	56.92	130.4	0.005	0.012	0.150
C_112	1	11	1.23	28.59	154.8	0.001	0.012	0.156
C_113	1	20	0.3	10.59	94.4	0.164	0.012	0.160
C_114	1	19	0.36	34.25	238.5	0.093	0.012	0.158
C_115	1	18	0.95	11.69	368.2	0.017	0.012	0.131
C_116	1	13	1.36	46.52	189.5	0.001	0.012	0.150
C_117	1	10	1.61	15.63	335.9	0.001	0.012	0.101
C_118	1	12	4.9	60.49	135.8	0.001	0.012	0.198
C_119	1	22	7.47	51.59	547.2	0.255	0.012	0.152
C_120	1	21	7.32	6.84	553.9	0.196	0.012	0.162

The junctions and outfall of the drainage system need to have invert elevations. As it was done with the subcatchments, select each junction individually into the Property Editor and set its Invert Elevation to the value shown below.

Table B.2. Input data to the Node and Outfall

Node Name	Elevation	Node Name	Elevation	Node Name	Elevation
1	208.55	41	204.08	81	207.35
2	208.42	42	204.05	82	208.30
3	208.41	43	204.05	83	208.56
4	208.44	44	204.04	84	207.82
5	208.30	45	203.99	85	208.05
6	208.17	46	203.95	86	208.24
7	208.13	47	203.90	87	209.40
8	208.07	48	203.86	88	209.40
9	207.60	49	203.83	89	209.40
10	204.94	50	203.77	90	209.48
11	204.92	51	203.73	91	209.12
12	207.67	52	206.70	92	209.00
13	206.90	54	207.78	93	208.50
14	207.85	55	206.95	94	208.45
15	207.89	56	207.32	95	207.45
16	207.81	57	207.30	96	207.08
17	207.51	58	208.10	97	206.97
18	207.37	59	208.30	98	206.68

Node Name	Elevation	Node Name	Elevation	Node Name	Elevation
19	207.17	60	208.26	99	204.16
20	204.91	61	209.25	100	204.70
21	204.89	62	209.25	101	205.50
22	204.86	63	209.24	102	205.38
23	204.82	64	209.24	103	205.66
24	204.77	65	210.06	104	205.90
25	204.73	66	209.85	105	204.53
26	204.69	67	209.38	106	204.44
27	204.64	68	209.57	107	204.35
28	204.60	69	208.00	108	204.25
29	204.56	70	208.55	109	204.10
30	204.51	71	208.32	110	204.45
31	204.47	72	207.45	111	205.28
32	204.45	73	207.08	112	206.31
33	204.43	74	206.70	113	205.45
34	204.39	75	206.64	114	205.27
35	204.34	76	206.60	115	203.93
36	204.30	77	207.08	116	204.28
37	204.25	78	207.20	117	205.11
38	204.21	79	207.32	118	206.14
39	204.16	80	207.20	119	205.55
40	204.12	Outfall			203.32

Similarly update the link properties as shown below:

Table B.3. Input data to the Conduits

Conduit Name	From Node	To Node	Length	Roughness	Conduit Name	From Node	To Node	Length	Roughness
1	1	2	33.3	0.014	61	62	63	108.3	0.014
2	2	3	64.4	0.014	62	63	64	64.7	0.014
3	3	4	29.8	0.014	63	64	65	141.9	0.014
4	4	5	16.7	0.014	64	65	66	74.7	0.014
5	5	6	21.3	0.014	65	66	67	86.6	0.014
6	6	7	18.2	0.014	66	67	68	98.7	0.014
7	7	8	59.5	0.014	67	68	69	95.6	0.014
8	8	9	30.4	0.014	68	69	70	89.7	0.014
9	9	10	167.6	0.014	69	70	71	108.6	0.014
10	10	11	152.0	0.014	70	71	72	95.2	0.014
11	11	20	20.0	0.014	71	72	73	88.2	0.014
12	12	13	135.8	0.014	72	73	74	118.6	0.014
13	13	18	40.4	0.014	73	74	75	87.4	0.014
14	14	15	48.3	0.014	74	75	42	319.2	0.014
15	15	16	19.6	0.014	75	76	77	98.5	0.014

Conduit Name	From Node	To Node	Length	Roughness	Conduit Name	From Node	To Node	Length	Roughness
16	16	17	61.2	0.014	76	77	78	104.0	0.014
17	17	18	69.1	0.014	77	78	79	83.6	0.014
18	18	19	47.0	0.014	78	79	80	91.8	0.014
19	19	20	37.1	0.014	79	80	81	112.0	0.014
20	20	21	288.0	0.014	80	81	82	102.1	0.014
21	21	22	305.0	0.014	81	82	83	95.5	0.014
22	22	23	242.0	0.014	82	83	84	89.7	0.014
23	23	24	363.0	0.014	83	84	85	80.3	0.014
24	24	25	310.0	0.014	84	85	86	126.1	0.014
25	25	26	300.0	0.014	85	86	87	59.8	0.014
26	26	27	300.0	0.014	86	87	88	25.2	0.014
27	27	28	310.0	0.014	87	88	89	108.1	0.014
28	28	29	310.0	0.014	88	89	90	178.2	0.014
29	29	30	300.0	0.014	89	90	91	75.5	0.014
30	30	31	310.0	0.014	90	91	92	36.6	0.014
31	31	32	150.0	0.014	91	92	93	191.4	0.014
32	32	33	150.0	0.014	92	93	94	6.7	0.014
33	33	34	300.0	0.014	93	94	95	169.6	0.014
34	34	35	310.0	0.014	94	95	96	99.1	0.014
35	35	36	290.0	0.014	95	96	97	27.8	0.014
36	36	37	326.0	0.014	96	97	98	98.9	0.014
37	37	38	298.7	0.014	97	98	43	391.9	0.014
38	38	39	308.3	0.014	98	100	101	108.2	0.014
39	39	40	298.6	0.014	99	101	102	71.0	0.014
40	40	41	297.5	0.014	100	102	103	102.2	0.014
41	41	42	136.2	0.014	101	103	104	98.6	0.014
42	42	43	15.1	0.014	102	104	42	42.1	0.014
43	43	44	146.3	0.014	103	105	106	101.5	0.014
44	44	45	299.9	0.014	104	106	107	98.7	0.014
45	45	46	309.8	0.014	105	107	108	100.3	0.014
46	46	47	310.0	0.014	106	108	99	98.6	0.014
47	47	48	300.0	0.014	107	99	43	6.5	0.014
48	48	49	229.9	0.014	108	100	109	103.9	0.014
49	49	50	389.9	0.014	109	109	110	96.8	0.014
50	50	51	299.8	0.014	110	110	111	87.7	0.014
52	52	54	126.3	0.014	111	111	112	87.7	0.014
53	54	55	87.5	0.014	112	112	113	101.7	0.014
54	55	56	80.0	0.014	113	113	114	60.4	0.014
55	56	57	122.7	0.014	114	114	51	10.7	0.014
56	57	58	82.9	0.014	115	105	115	99.9	0.014
57	58	59	94.8	0.014	116	115	116	97.9	0.014
58	59	60	97.1	0.014	117	116	117	97.9	0.014
59	60	61	83.3	0.014	118	117	118	99.5	0.014

Conduit Name	From Node	To Node	Length	Roughness		Conduit Name	From Node	To Node	Length	Roughness
60	61	62	90.0	0.014		119	118	119	98.6	0.014
						120	119	114	45.3	0.014

In order to deliver a rainfall input to the project, it is necessary to set the rain gage's properties.

- Chose Rain Gage 1 into the Property Editor and set the properties:
- Rain Format - Volume, Time Interval - 0.10, Data Source – TIMESERIES, Series Name – Hyetograph.
- A time series named Rainfall will contain the 10 minute interval rainfall depth that make up the storm.
- Thus a time series 'Hyetograph' object need to be created and populated with data.

Steps to do this:

- From the Data Browser select the Time Series category.
- Click the button on the Browser to bring up the Time Series Editor dialog.
- Enter Rainfall in the Time Series Name field.
- Enter the values into the Time and Value columns.

Having completed the preliminary design of the example project, from the File menu select the Save As option.

In the Save As dialog that appears, select a folder and file name in which to save this assignment. Thus, at the end of this process the area has been mapped to represent the natural and physical characteristics of the urban area in question. The next step is to use all these characteristics to generate the runoff in response to a known rain storm through the simulation process.

RUNNING A SIMULATION OF SWMM NETWORK

Initial Setting for Simulation of SWMM Network:

To analyze the performance of the drainage system, one needs to fix some options.

- From the Data Browser, select the Options category and click the  but ton.
- On the General page of the Simulation Options dialog (Figure B.7) that appears, select flow routing method as Dynamic Wave.
- On the Dates page of the dialog, set the End Analysis time to 06:00:00 (6 hour event)

- On the Time Steps page, set the Routing Time Step to 1 second.
- Set the Reporting time to 5sec and Wet weather and Dry Weather Runoff calculation interval each to 1min.
- Click OK to close the Simulation Options dialog.

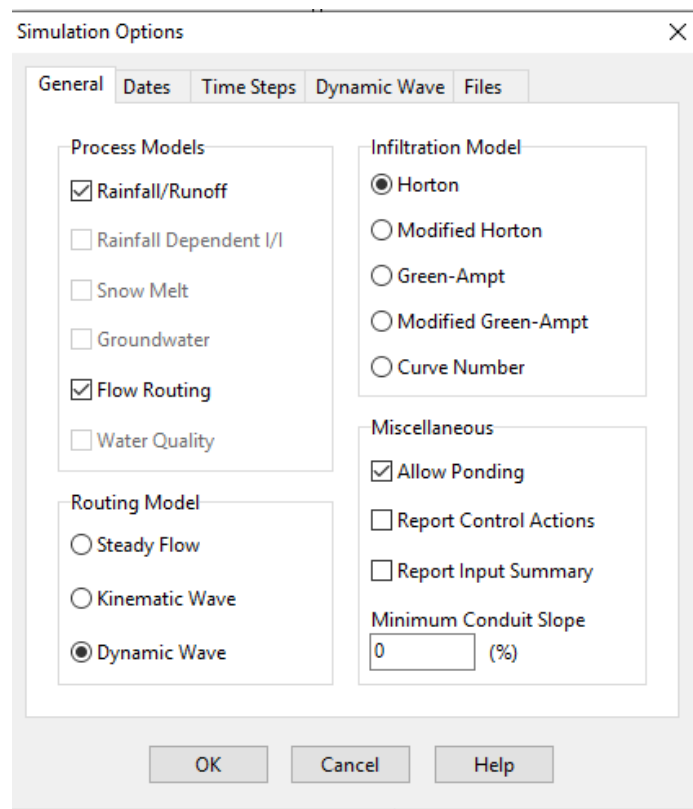

Figure B.7. Simulation Options

- With this, the model is now ready for performing simulation.
- To do so, select Project >> Run Simulation (or click the  button).
- If there was a problem with the model, a Status Report will appear, describing what errors happened.
- The Status Report covers useful summary about the outcomes of a simulation run.
- To view the report select Report >> Status.
- Notice that the continuity errors for runoff and conduit routing are small (typically <1%).
- The Node Flooding Summary (Table B.4) indicates that there was internal flooding in the system at different nodes.

Table B.4. Node Flooding Results

Node	Hours Flooded	Maximum Rate CMS	Day of Maximum Flooding	Hours of Maximum Flooding	Total Flood Volume (10 ⁶ ltr)
35	0.59	12.148	0	01:57	15.086
39	0.92	5.922	0	02:19	12.801
50	4.47	29.015	0	02:00	201.56
52	5.47	3.88	0	01:20	29.707
55	1.52	3.523	0	01:10	11.099
57	0.97	1.267	0	01:10	1.872
58	0.95	0.748	0	01:10	1.239
60	0.9	1.118	0	01:10	1.727
63	0.42	0.908	0	01:10	0.755
64	0.85	2.945	0	01:10	4.778
69	0.95	3.787	0	01:10	5.428
76	4.85	2.126	0	01:12	4.623
108	0.01	0.11	0	01:39	0.003
109	0.55	2.277	0	01:10	2.408
115	0.67	1.657	0	01:42	1.554

Displaying Results on the Map

Simulation outcomes can be viewed in colour coded style on the study area map.

To view a particular variable in this fashion:

- Select the Map page of the Browser.
- Select the variables to view for Subcatchments, Nodes, and Links from the dropdown box appearing in the Themes. In Figure B.8, subcatchment runoff, node total inflow and link depth at 02:11:08 have been selected for viewing.
- To display of a legend, select View >> Legends.
- To move a legend to another location, drag it with the left mouse button held down.
- To change the colour coding, select View >> Legends >> Modify.
- To view numerical values for the variables being displayed on the map, select Tools >> Map Display Options and then select the Annotation page of the Map Options Dialog.

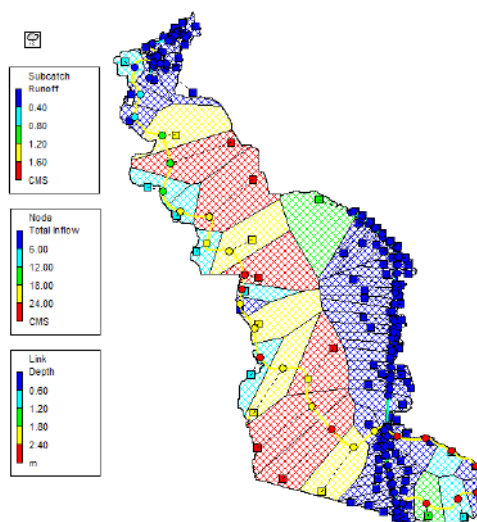

Figure B.8. Subcatchment runoff, node total inflow and link depth at 02:11:08

Analysis of a Time Series Plot

To produce a time series plot of a model simulation result:

- Select Report >> Graph >> Time Series.
- A Time Series dialog will appear. It is used to select the objects and variables to be plotted. For this example, the Time Series Plot is used to graph the flow in channel 46 (refer to Figure B.9):
- Select Links as the Object Category
- Select Flow as the Variable to plot
- Click on conduit 46 and then click
- Press OK to create the plot, which should look like as in Figure B.10.

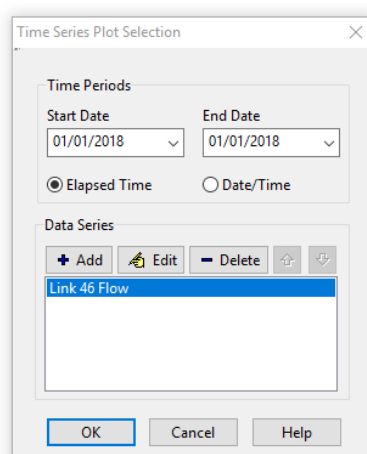

Figure B.9. Data series selection

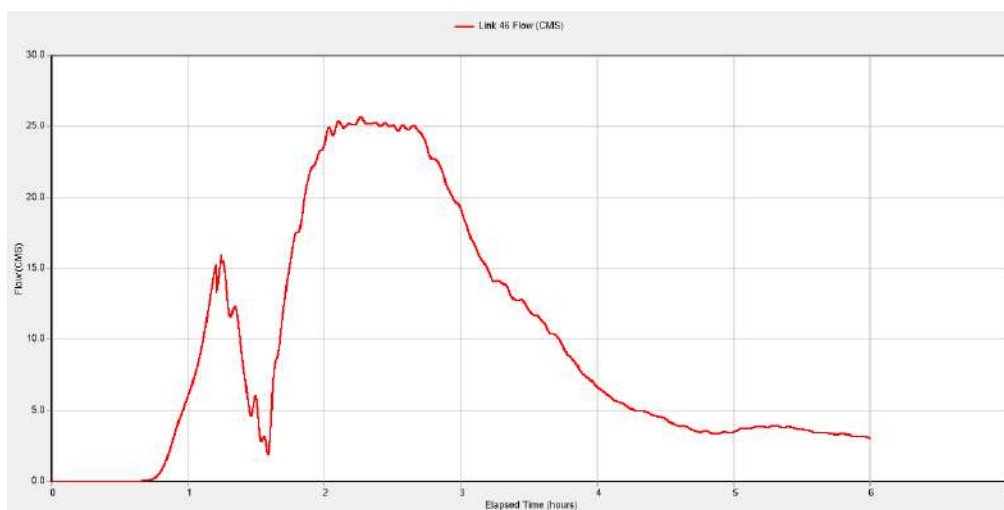

Figure B.10. Time series plot of results (Flow in the conduit 46)

After a plot is created one can:

- customize its appearance by selecting Report >> Customize
- copy it to the clipboard and paste it into another application by selecting Edit > Copy To
- Print it by selecting File >> Print.

Seeing a Profile Plot: SWMM can produce profile plots, depicting water surface depth variation all along the path of connected nodes and links.

To create such a plot for the links connecting junction 44 to the outfall 53 of this example, following steps can be taken:

- Select Report >> Graph >> Profile.
- Enter 44 in the Start Node field of the Profile Plot dialog (Figure B.11)
- Repeat the steps for node Outfall 53 in the End Node field of the dialog
- Click the Find Path button
- Click the OK button to create the plot, showing the water surface profile (Figure B.12)

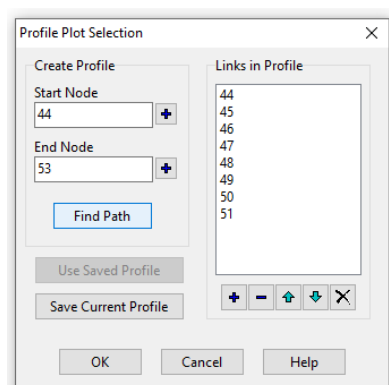

Figure B.11. Profile Plot dialog box

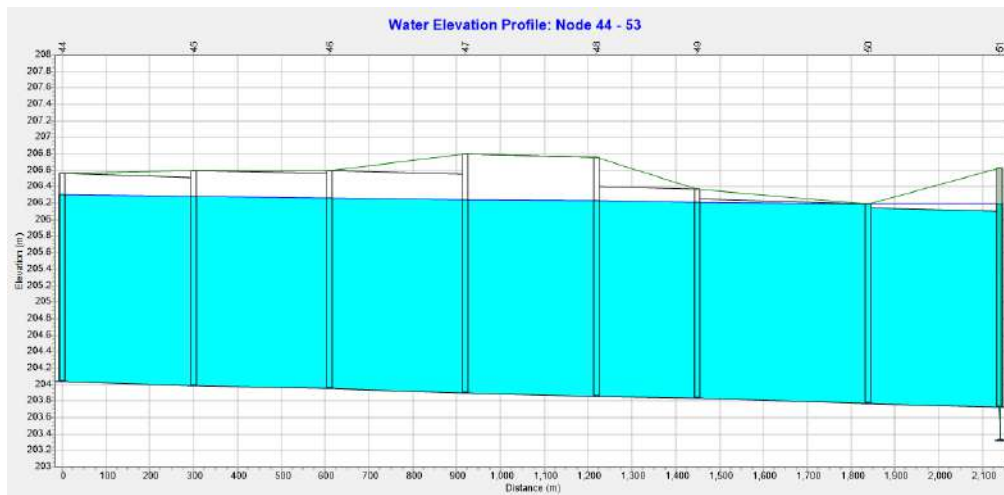

Figure B.12. Illustration of Profile Plot

Options: Resizing the Network.

In order to minimise the flooding, one of the options can be to make some modifications to size and slope of the Links which can be worked out in an iterative manner keeping in view the local constraints with respect to space and terrain.

EXAMPLE - NETWORK 2

The objective of this example is to develop a simple surface drainage system using the 5-year return period rainfall event. This example will demonstrate how SWMM's hydraulic elements and flow routing methods can be used to model this surface drainage system of an undeveloped area. Figure C.1 shows a 223.57 ha natural catchment area. This undeveloped area primarily comprises of agricultural land with a *sandy loam* soil type.

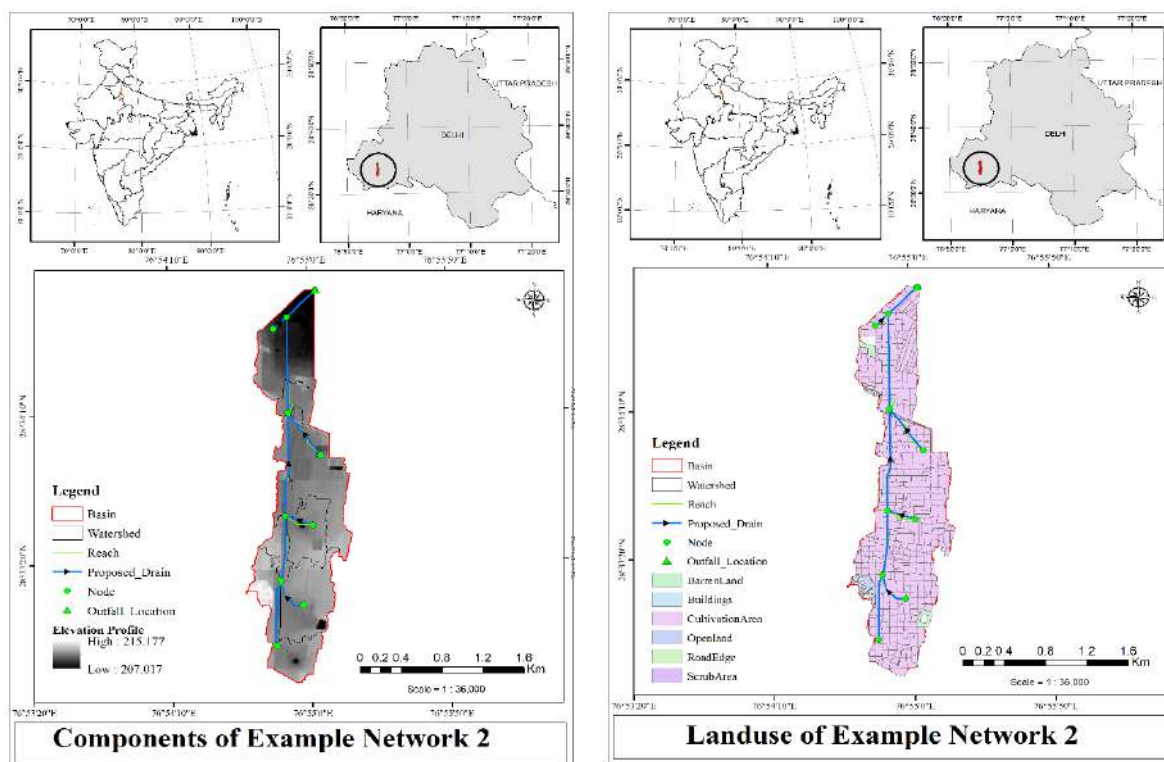

Figure C.1. Example Network Component and Land use

SYSTEM REPRESENTATION

SWMM is a distributed model, i.e. a study area can be subdivided into any number of irregular subcatchments to best capture the effect of topography, drainage pathways, land cover, and soil characteristics on runoff generation. An idealized subcatchment is conceptualized as a rectangular surface that has a uniform slope and a width W that drains to a single outlet channel. Each subcatchment can be further divided into three subareas: an impervious area with depression (detention) storage, an impervious area without depression storage and a pervious area with depression storage. Only the latter area allows for rainfall losses due to infiltration into the soil. SWMM models a conveyance network as a series of nodes connected by links (Figure C.1). Links control the rate of flow from one node to the next and are typically conduits. Nodes define the elevation of the drainage system and the time-varying hydraulic head

applied at the end of each link it connects. The flow conveyed through the links and nodes of the model is ultimately discharged to a final node called the outfall.

WATERSHED DELINEATION AND CHARACTERISTICS

Better Assessment Science Integrating point and Nonpoint Sources (BASINS) automated Delineation tool delineated the basin into 9 sub-watersheds using the five meter DEM (Figure C.1) with a total area of 223.57 ha. BASINS is a reliable tool for digital watershed delineation. BASINS' automated watershed delineation provided not only sub watershed boundaries and area, but also basic information on watershed characteristics, such as slope, stream reach length, area percentages of land use and soil types. This catchment runoff is out falling into Mundela drain which is the sub drain of Najafgarh drain in Delhi. The output of BASINS (Shapefile) was converted into image file and it was used as backdrop image to placement of different features like subcatchment, node outfall and conduits in the SWMM model.

Subcatchment Inputs

The hydrologic characteristics of a study area's subcatchments are defined by the following set of input parameters in SWMM:

Area: This is the area bounded by the each subcatchment boundary. Its value is determined directly from maps or as BASINS output or by using SWMM's Auto Length tool when the subcatchment is drawn to scale on SWMM's study area map.

Width: The width can be defined as the sub catchment's area divided by the length of the longest overland flow path that water can travel.

Slope: This is the slope of the land surface over which runoff flows and is the same for both the pervious and impervious surfaces.

Imperviousness: This is the percentage of the subcatchment area that is covered by impervious surfaces, such as roofs and roadways, through which rainfall cannot infiltrate.

Roughness Coefficient: The roughness coefficient reflects the amount of resistance that overland flow encounters as it runs off of the subcatchment surface. Since SWMM uses the Manning equation to compute the overland flow rate, this coefficient is the same as Manning's roughness coefficient n .

Depression Storage: Depression storage corresponds to a volume that must be filled prior to the occurrence of any runoff.

Percent of Impervious Area without Depression Storage: This parameter accounts for immediate runoff that occurs at the beginning of rainfall before depression storage

is satisfied. By default the value of this variable is 25%, but it can be changed in each subcatchment.

Infiltration Model: Three different methods for computing infiltration loss on the pervious areas of a subcatchment are available in SWMM. They are the Horton, Green Ampt and Curve Number models. There is no general agreement on which model is best.

The parameters for this model include: Maximum infiltration rate: This is the initial infiltration rate at the start of a storm. It is difficult to estimate since it depends on the antecedent soil moisture conditions.

Minimum infiltration rate: This is the limiting infiltration rate that the soil attains when fully saturated. It is usually set equal to the soil's saturated hydraulic conductivity. It has a wide range of values depending on soil type.

Decay coefficient: This parameter determines how quickly the infiltration rate "decays" from the initial maximum value down to the minimum value. Typical values range between 2 to 7 hr⁻¹.

Precipitation Input:

Precipitation is the principal driving variable in rainfall-runoff-quantity simulation. The volume and rate of stormwater runoff depends directly on the precipitation magnitude and its spatial and temporal distribution over the catchment. Each subcatchment in SWMM is linked to a Rain Gage object.

The SWMM model for the undeveloped site is depicted in Figure C.3. It consists of a rain gage1 that provides precipitation input to the subcatchments whose runoff drains to outfall node. Note that the undeveloped BASINS tool outputs has been used as a backdrop image on which the subcatchments outline has been drawn. The SWMM input for subcatchments is listed in the Table C.1 and Table C.2.

Various rain data formats that can be used in SWMM5 are:

- (a) CUMULATIVE - the cumulative rainfall depth measured during each recording interval
- (b) INTENSITY - average rainfall rate over each recording interval and
- (c) VOLUME - incremental rainfall depth in each recording interval.

In this example, Volume format is applied to a different subcatchment. The rainfall hyetograph is shown in the Figure C.2 and developed SWMM model is shown in the Figure C.3.

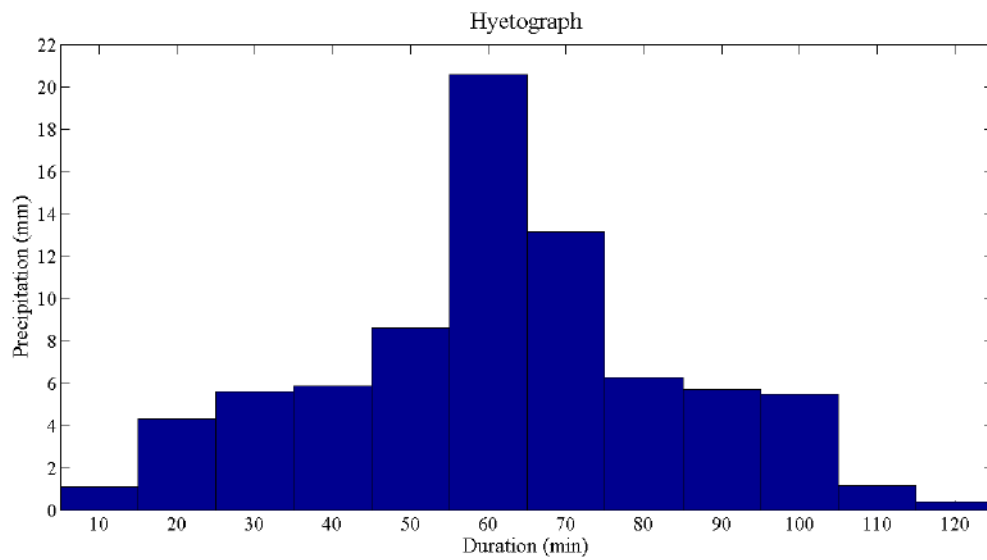

Figure C.2 Rainfall Hyetograph

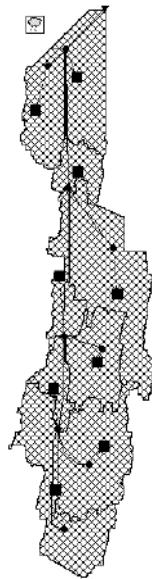

Figure C.3. SWMM Example Network 2

Table C.1. Input data to the Subcatchment

Name	Rain Gage	Outlet	Area	% Impervious	Width	%Slope	N Impervious (manning)	N Pervious (manning)
C_1	1	5	26.04	2	229.52	0.72	0.012	0.17
C_2	1	10	21.46	5	216.08	1.00	0.012	0.17
C_3	1	4	10.69	1	65.05	0.83	0.012	0.17
C_4	1	9	46.96	2	239.67	0.86	0.012	0.17
C_5	1	3	13.73	2	100.65	0.84	0.012	0.17
C_6	1	8	22.98	2	241.22	0.77	0.012	0.17

Name	Rain Gage	Outlet	Area	% Impervious	Width	%Slope	N Impervious (manning)	N Pervious (manning)
C_7	1	2	9.54	2	118.66	0.99	0.012	0.17
C_8	1	7	37.11	2	291.40	0.90	0.012	0.17
C_9	1	1	35.03	22	245.46	1.20	0.011	0.17

Table C.2. Infiltration Inputs to the Subcatchment

Subcatchment	Maximum Infiltrations Rate	Minimum Infiltrations Rate	Decay Coefficient	Dry Time
C_1	4.25	0.4	3	2
C_2	4.25	0.4	3	2
C_3	4.25	0.4	3	2
C_4	4.25	0.4	3	2
C_5	4.25	0.4	3	2
C_6	4.25	0.4	3	2
C_7	4.25	0.4	3	2
C_8	4.25	0.4	3	2
C_9	4.25	0.4	3	2

Conduit Inputs:

The conduits are simply the reach that connects the subcatchments. Like the subcatchment properties, BASINS tool and tables available in the SWMM manual can be used to define conduit properties. The conduit properties considered in this project are as follows:

- Shape
 - Width
 - Side slopes
 - Depth
- Length
- Roughness

SWMM has available several default channel shapes, but a trapezoidal channel shape was chosen because of its rough resemblance. To define the width of the channel, its depth a trial and error procedure is adapted. A summary of the shape properties are shown in the table below:

Table C.3. Input data to conduits

Conduit Name	From Node	To Node	Length	Roughness	Depth	Width
1	1	2	681.73	0.012	0.75	2.25
2	2	3	668.9	0.012	1.0	3.0
3	3	4	1065.48	0.012	1.0	3.0
4	4	5	987.49	0.012	1.0	3.5
5	5	6	393.75	0.012	1.0	4.0
6	7	2	384.36	0.012	0.7	2.1
7	8	3	282.95	0.012	0.7	2.1
8	9	4	536.05	0.012	0.75	2.25
9	10	5	175.04	0.012	1.0	3.0

The length property could be determined using the BASINS tool. Finally, the roughness of the stream could be estimated with the help of a table of typical roughness coefficient.

Junctions and Outfall Inputs

Only one junction property, the invert elevation, will be directly considered in this Example. An option to define the maximum depth at the junction is available, but it will be assumed that it is the same as the depth of the connecting conduit. Furthermore, initial depth will be ignored since the results will centre only on the flow from runoff and not base flow. The invert elevation is simply the elevation at the junction measured from sea level. As has been mentioned previously, elevation data are available from the DEM and can be easily input to SWMM.

Table C.4. Input data to the Node and Outfall

Node Name	Elevation
1	212.570
2	211.950
3	211.342
4	210.374
5	209.476
7	212.300
8	211.599
9	210.861
10	209.635
Outfall	209.117

RUNNING SWMM TO SIMULATE THE NETWORK

Initial Setting for Simulation of the Network:

- To Analyzing the performance of the drainage system, it is required to fix some options.
- From the Data Browser, select the Options category and click the  button.
- On the General page of the Simulation Options dialog that appears, select flow routing method is Dynamic Wave.
- On the Dates page of the dialog, set the End Analysis time to 12:00:00.
- On the Time Steps page, set the Routing Time Step to 1 second.
- Set the Reporting time to 5sec and Wet weather and Dry Weather Runoff calculation intervals each to 1min.
- Click OK to close the Simulation Options dialog.

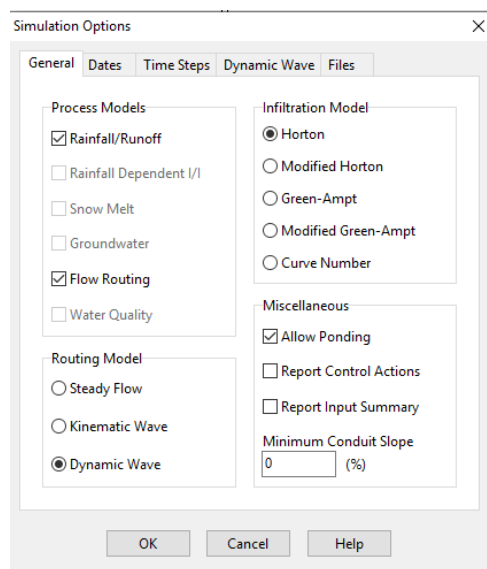



Figure C.4. Simulation Options

- The model is now ready to run for simulation.
- To do so, select Project >> Run Simulation (or click the  button).
- If there was a problem with the model, a Status Report will appear, describing what errors happened.
- The Status Report covers useful summary data about the outcomes of a simulation run.
- To view the report select Report >> Status.
- Notice that the continuity errors for runoff and conduit routing are small (typically <1%).

- The Node Flooding Summary indicates there was no internal flooding in the system implying that the sizes selected are adequate.

Displaying Results on the Map

Simulation outcomes can be viewed in colour coded style on the study area map.

To view a particular variable in this fashion:

- Select the Map page of the Browser.
- Select the variables to view for Subcatchments, Nodes, and Links from the dropdown boxes appearing in the Themes. In Figure C.5, subcatchment runoff, node lateral inflow and link flow have been selected for viewing at 02:16:25.
- To display of a legend, select View >> Legends.
- To move a legend to another location, drag it with the left mouse button held down.
- To change the colour coding, select View >> Legends >> Modify.
- To view numerical values for the variables being displayed on the map, select Tools >> Map Display Options and then select the Annotation page of the Map Options dialog.

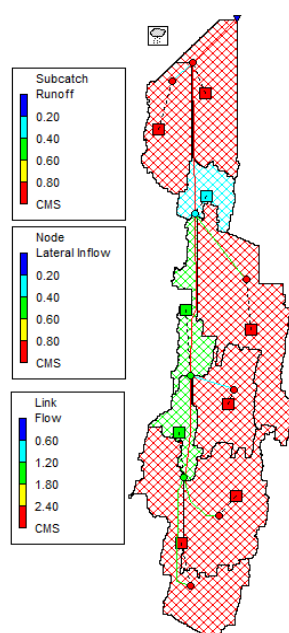

Figure C.5. Subcatchment runoff, node lateral inflow and link flow at 02:16:25.

Analysis of Time Series Plot

To produce a time series plot of a model result:

- Select Report >> Graph >> Time Series.

- A Time Series dialog will appear. It is used to select the objects and variables to be plotted. For this example, the Time Series Plot can be used to plot the flow in conduit no 1 to 6. (Refer Figure C.6):
 - Select Links as the Object Category
 - Select Flow as the Variable to plot
 - Click on conduit 1 and then click on Add icon
 - Repeat the same procedure for all conduits
 - Press OK to create the plot, which should look like as in Figure C.7.

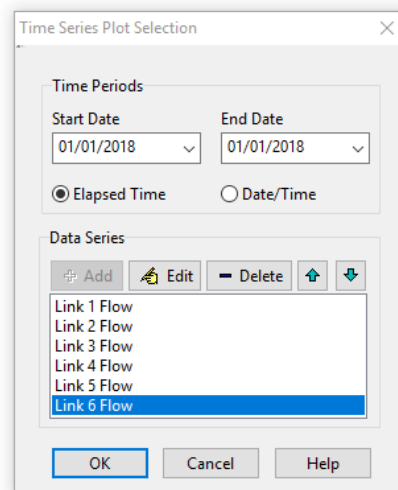

Figure C.6. Data series selection

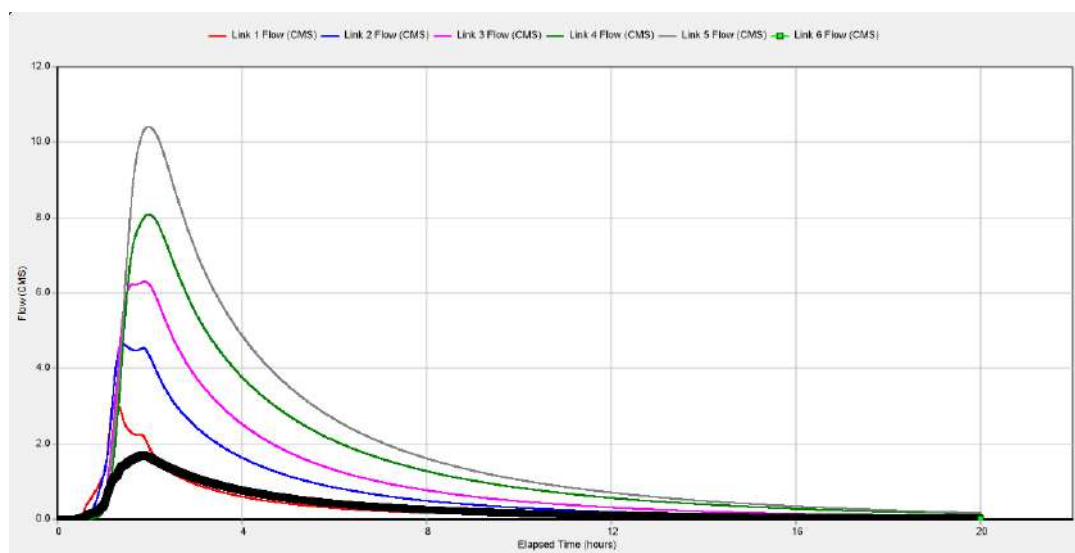

Figure C.7. Time series plot of results (Flow in the conduit no 1 to 6)

After a plot is created one can:

- Customize its appearance by selecting Report >> Customize
- Copy it to the clipboard and paste it into another application by selecting Edit >> Copy To

- Print it by selecting File >> Print.

Seeing a Profile Plot: SWMM can produce profile plots showing how water surface depth varies all along the path of connected nodes and links.

To create profile plot for the links connecting junction 1 to the outfall 6 presented in this example. To create this following steps need to be followed:

- Select Report >> Graph >> Profile.
- Enter 1 in the Start Node field of the Profile Plot dialog (Figure C.8.)
- Do the same for node Outfall 6 in the End Node field of the dialog.
- Click the Find Path button.
- Click the OK button to create the plot, showing the water surface profile (Figure C.9).

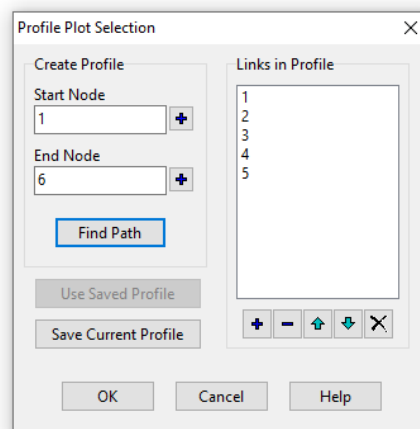

Figure C.8. Profile Plot dialog box

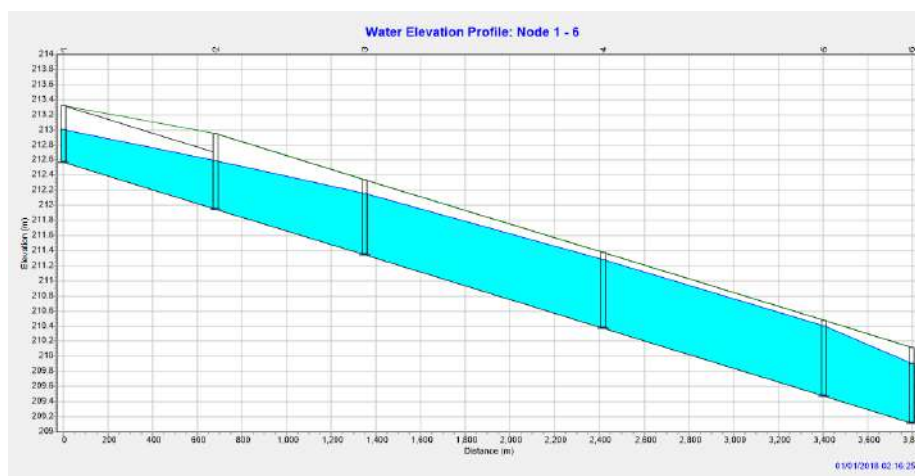

Figure C.9. Illustration of a Profile Plot

Table C.5 provide the total rainfall, total runoff volume, peak runoff discharge and total infiltrated volume for the design storm. These values came directly from the Subcatchment Runoff Summary table that appears in the Status Report of a SWMM run.

Table C.5. Outputs of Subcatchments (Total Precipitation, Total Infiltration, Total Runoff and Peak Runoff)

Subcatchment	Total Precipitation (mm)	Total Infiltration (mm)	Total Runoff (mm)	Total Runoff 10 ⁶ ltr	Peak Runoff (CMS)
C_1	78.17	9.03	64.4	16.77	1.22
C_2	78.17	8.76	67.12	14.4	1.29
C_3	78.17	9.12	61.24	6.55	0.39
C_4	78.17	9.03	59.68	28.03	1.55
C_5	78.17	9.03	63.45	8.71	0.6
C_6	78.17	9.03	65.99	15.16	1.25
C_7	78.17	9.03	67.75	6.46	0.63
C_8	78.17	9.03	64.37	23.89	1.74
C_9	78.17	7.19	68.71	24.07	3.15

The model simulates the flow throughout the drainage system, and can display outputs at any of the nodes or conduits in the drainage system. At each node, the depth, head, lateral inflow and total inflow can be found over the duration of the rain event. The outputs of the model are given in the Table C.6, Table C.7 and Table C.8.

Table C.6. Outputs of Nodes (Average depth, Maximum depth, Maximum HGL, Hours of Maximum Depth and Maximum Reported Depth)

Node	Type	Average depth (m)	Maximum depth (m)	Maximum HGL (m)	Day of Maximum Depth (m)	Hours of Maximum Depth (m)	Maximum Reported Depth (m)
10	JUNCTION	0.19	0.81	210.45	0	01:54	0.81
5	JUNCTION	0.33	0.97	210.44	0	01:57	0.97
9	JUNCTION	0.19	0.56	211.42	0	01:52	0.56
4	JUNCTION	0.3	0.94	211.31	0	01:58	0.94
3	JUNCTION	0.26	0.88	212.23	0	01:53	0.88
8	JUNCTION	0.14	0.67	212.27	0	01:50	0.67
2	JUNCTION	0.21	0.74	212.69	0	01:25	0.74
7	JUNCTION	0.16	0.53	212.83	0	01:50	0.53
1	JUNCTION	0.14	0.69	213.26	0	01:12	0.69
6	OUTFALL	0.24	0.82	209.94	0	01:58	0.82

Table C.7. Outputs of Nodes (Maximum Lateral Inflow, Maximum Total Inflow, Hours of Maximum Inflow, Lateral Inflow Volume and Total Inflow Volume)

Node	Type	Maximum Lateral Inflow (CMS)	Maximum Total Inflow (CMS)	Day of Maximum Inflow (CMS)	Hours of Maximum Inflow (CMS)	Lateral Inflow Volume 10 ⁶ ltr	Total Inflow Volume 10 ⁶ ltr
10	JUNCTION	1.289	1.289	0	01:50	14.4	14.4
5	JUNCTION	1.223	10.429	0	01:55	16.8	143
9	JUNCTION	1.554	1.554	0	01:50	28	28
4	JUNCTION	0.391	8.205	0	01:52	6.55	113
3	JUNCTION	0.596	6.37	0	01:50	8.71	78.2
8	JUNCTION	1.251	1.251	0	01:50	15.2	15.2
2	JUNCTION	0.63	4.828	0	01:21	6.46	54.4
7	JUNCTION	1.737	1.737	0	01:50	23.9	23.9
1	JUNCTION	3.146	3.146	0	01:10	24.1	24.1
6	OUTFALL	0	10.409	0	01:58	0	143

Table C.8 lists the each conduit flow and velocity for the 5 year rain event. These values are available from the Link Flow Summary table of SWMM's Status Report.

Table C.8. Outputs of Nodes (Maximum Flow, Hour of Maximum Flow, Maximum Velocity and Max/Full Depth)

Link	Type	Maximum Flow (CMS)	Day of Maximum Flow (CMS)	Hour of Maximum Flow (CMS)	Maximum Velocity (m/sec)	Max/Full Depth
1	CONDUIT	3.102	0	01:14	1.58	0.93
2	CONDUIT	4.648	0	01:25	1.61	0.81
3	CONDUIT	6.314	0	01:53	1.86	0.91
4	CONDUIT	8.09	0	01:58	1.9	0.95
5	CONDUIT	10.409	0	01:58	2.38	0.9
6	CONDUIT	1.72	0	01:51	1.04	0.88
7	CONDUIT	1.242	0	01:50	0.71	0.98
8	CONDUIT	1.511	0	01:52	1.11	0.87
9	CONDUIT	1.273	0	01:50	0.92	0.89

The flow peak through the most upstream conduit (conduit 1) is approximately 3.102 CMS. The flow peak through the middle segment (conduit 2) is approximately 4.648 CMS. The peak flow through the most downstream segment (conduit 5) is approximately 10.409 CMS.

Conduit 1 gets lowest flow, because very small area drains into it. Conduit 2 gets more flow than conduit 1, because flow in conduit 2 is summation of flow from upstream catchment through conduit 1 and flow generated from its own catchment. Since conduit 5 is the last conduit and gets contribution from all upstream catchments, highest flow is observed in conduit 5.



एक कदम स्वच्छता की ओर

CLEANLINESS PLEDGE

Mahatma Gandhi dreamt of an India which was not only free but also clean and developed.
Mahatma Gandhi secured freedom for Mother India.

Now it is our duty to serve Mother India by keeping the country neat and clean.

I take this pledge that I will remain committed towards cleanliness and devote time for this.
I will devote 100 hours per year, that is two hours per week, to voluntarily work for cleanliness. I
will neither litter nor let others litter.

I will initiate the quest for cleanliness with myself, my family, my locality, my village and my work
place.

I believe that the countries of the world that appear clean are so because their citizens don't
indulge in littering nor do they allow it to happen. With this firm belief, I will propagate the
message of Swachh Bharat Mission in villages and towns.

I will encourage 100 other persons to take this pledge which I am taking today. I will endeavour
to make them devote their 100 hours for cleanliness.

I am confident that every step I take towards cleanliness will help in making my country clean.

Do's

- Start cleanliness from home
- Keep surroundings clean and green
- Keep work place neat and clean
- Devote 2 hours a week on sanitation
- Dispose garbage in designated places.

Don'ts

- Don't litter and don't let others litter
- Don't defecate and urinate in open
- Don't deface public properties
- Don't spit in public places
- Don't dump garbage in drains/water bodies

Eligible Components Under Swachh Bharat Mission in Urban Local Bodies

Individual Household Toilets | Community Toilets | Public Toilets | Solid Waste Management

Central Public Health and Environmental Engineering Organisation (CPHEEO)

Ministry of Housing and Urban Affairs

Nirman Bhawan, Maulana Azad Road, New Delhi-110011

www.mohua.gov.in | www.cpheeo.gov.in | www.swachhbharaturban.gov.in